

# Technical What's New



**Autodesk**

## Alias® 2011 Family of Products

Autodesk® Alias® Design

Autodesk® Alias® Design for Inventor®

Autodesk® Alias® Surface

Autodesk® Alias® Automotive

**Autodesk**

# Technical What's New

## Welcome to the Autodesk® Alias® 2011 Family of Products

Purpose-built for industrial designers and creative professionals, digital modelers, and automotive/transportation designers, the Autodesk® Alias® product line—Autodesk® Alias® Design, Autodesk® Alias® Design for Inventor®, Autodesk® Alias® Surface, and Autodesk® Alias® Automotive—provides a complete set of tools for the creative design process. The scalable product line provides industry-leading surfacing capabilities supported by best-in-class sketching, modeling, and visualization tools that let you capture and communicate design intent.

Part of the Autodesk solution for Digital Prototyping, the Alias product line enables designers to capture their ideas digitally and then share them with engineering teams, ensuring that designs address both aesthetic and functional requirements. Fast, high-quality data integration and exchange with Autodesk® Inventor® software enables industrial design data to be incorporated into the digital prototype. Innovate ahead of the curve with Autodesk Alias software.

The 2011 Autodesk Alias products include:

- **Autodesk Alias Design** – For consumer product designers and creative professionals who control the entire design process—from ideation to the final surfaces that are passed to engineering. Designers can rapidly develop and communicate product design concepts using sketches, illustrations, photorealistic renderings, and animations.

- **Autodesk Alias Design for Inventor** – Engineers can take advantage of Alias Design capabilities with Autodesk Alias Design for Inventor. This new version was built specifically for Inventor users to provide integrated, free-form, shape-modeling capabilities directly within the Inventor environment.

- **Autodesk Alias Surface** – Offers a full set of dynamic 3D modeling capabilities that enable digital modelers to evolve concept models and scan data into high-quality production surfaces for consumer product design and Class-A surfaces for automotive design and styling.

- **Autodesk Alias Automotive** – The de facto standard for automotive design and the choice of leading automotive styling studios throughout the world. Alias Automotive includes all of the features in Autodesk Alias Design and Autodesk Alias Surface and provides a comprehensive set of visualization and analysis tools for the entire shape-definition process, from concept sketches through Class-A surfacing.

New and improved functionality in the Alias 2011 family of products further helps lower barriers of adoption and increases modeling productivity and design quality. This new release offers the following features and benefits:

- Ease-of-use and tools that help increase productivity
- Substantial display improvements
- Surfacing enhancements including higher levels of continuity
- New automotive evaluation functionality

For a complete summary of features and their corresponding product, please see the Features at a Glance section at the end of this document.

# Technical What's New

## General Improvements

### System Diagnostics

Alias now runs a system check to compare your hardware to the qualified hardware needed to run the application successfully. The system check automatically happens the first time the product is launched or if no Systems Diagnostics Log is found. Going forward, the system check will automatically occur on a monthly basis to confirm you are running at an optimal performance.

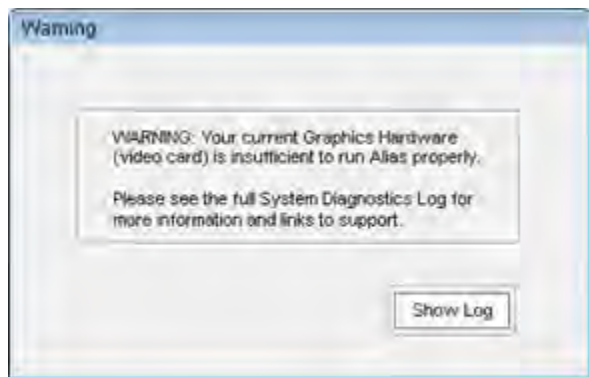

### Nonproportional View and Dolly Interaction

When modeling, you often need to judge geometry under a scaled view. To get to a specific non-proportional view, Alias 2011 now uses a box-pick method. When you click and drag, a box is drawn on the screen. When you release the mouse button, the window fills with the content of the box. This new method is much faster than the typical click and drag method. Since this is an action that is often performed several times a day, the time savings can be significant.

If you prefer to continue using the method in Alias 2010, you can turn off the new click-box feature completely or flip between old and new workflow methods.

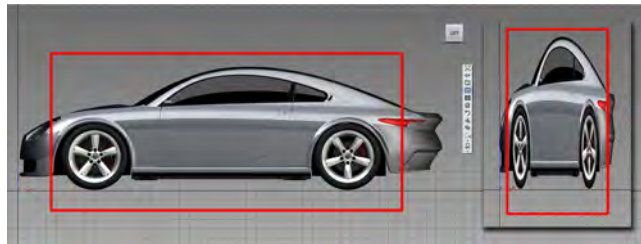

### Additive Selection Mode

Based on user feedback, a new selection mode (Add) is now available. In this mode, all picked objects are added to the selection. Already picked objects remain picked.

The "Middle mouse button" pull down menu shows the new option "Add". Users can choose to work in classic mode or can customize the mouse button selection method—pick, unpick, add, or toggle.



### Selection on the Interior of Surfaces

Surfaces can now be selected by clicking inside the wireframe. This is currently referred to as "Face selection" in the UI. Another customer-requested enhancement, this productivity-enhancing option will help save significant time.

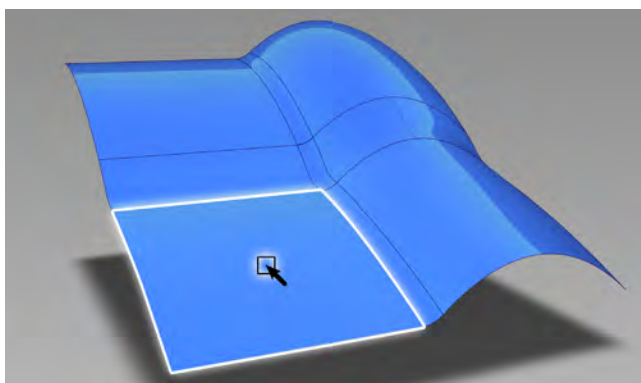

# Technical What's New

## Visualization

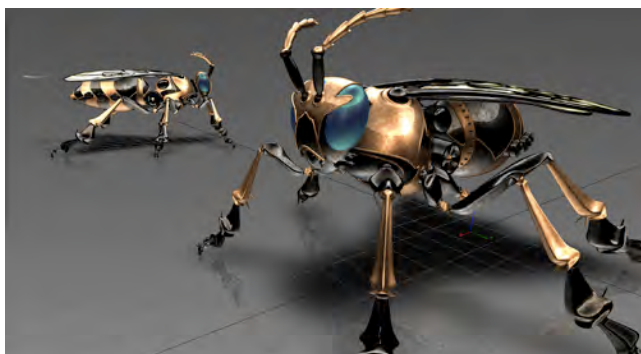

### Anti-Alias Setting Changes

Alias 2011 now offers the ability to choose between 3 different levels of hardware anti-aliasing: 4x, 8x, or 16x. Available for both wireframe and shade models, you can boost the level of anti-aliasing, depending on how much graphic power is needed.

### Improved Edge Display

The display of edges when surfaces overlap, especially when shaded, has been substantially improved.

### Surface Continuity Locators

The surface continuity locator display has been enhanced; locators appear crisper, allowing users to more clearly see the surface boundaries and their continuity.

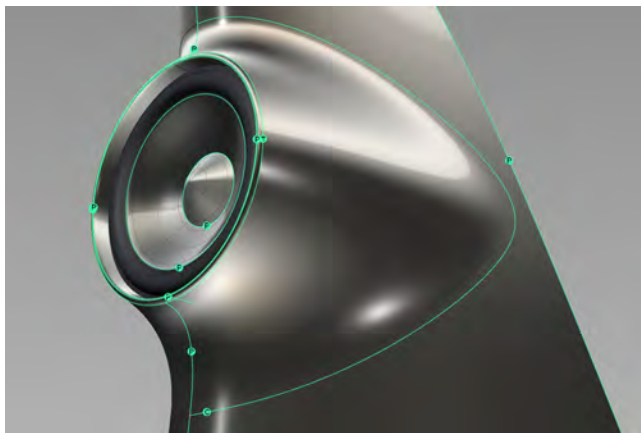

### Improved Ambient Occlusion Workflow

In Alias 2011, users will now be prompted to orient all surfaces to face the same way before starting a calculation. Because setting up the occlusion is a very time-consuming calculation, this new feature will help to alleviate the extra work that resulted in past releases when users forgot to set the normal direction before starting their ambient occlusion calculations.

## Modeling

### Improved Fit Curve Tool

We have redesigned the Curve Edit > Fit Curve tool to allow the fitting of a curve to other types of curves beside section data. These include curves on surfaces, trim edges, isoparms (including surface edges and patch precision lines), and regular curves.

The Fit Curve tool now provides fitting of 3D curves to Curve on Surface. This improvement will help users create substantially lighter surfaces and increase the overall mathematical quality level of surfaces created with either Alias Design, Alias Surface, or Alias Automotive.

### Offsetting Surfaces with Unified Normals

When offsetting several surfaces with Object Edit > Offset, an arrow now lets you choose the direction of the offset so that all surfaces are offset in a unified direction, regardless of their initial orientation.

This new feature is beneficial because users will no longer need to verify that each single surface normal is pointing in the right direction.

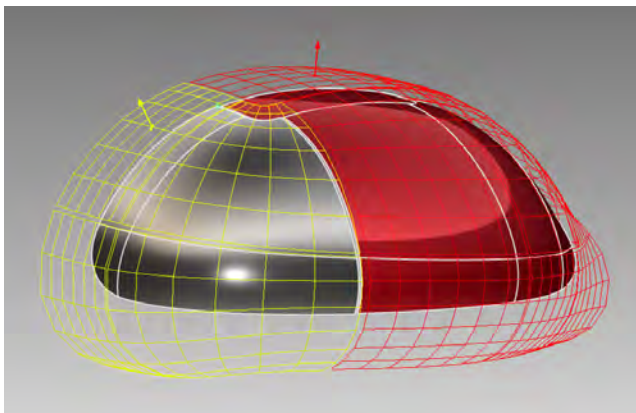

### G3 Continuity

Responding to the challenge of improving smooth surface transitions by introducing G3 continuity, a new section type option—G3— has been added to the Surface Fillet tool for advanced curvature continuity. In addition, an option has been added for G3 curvature capabilities in the Freeform Blend and Profile Blend tools.

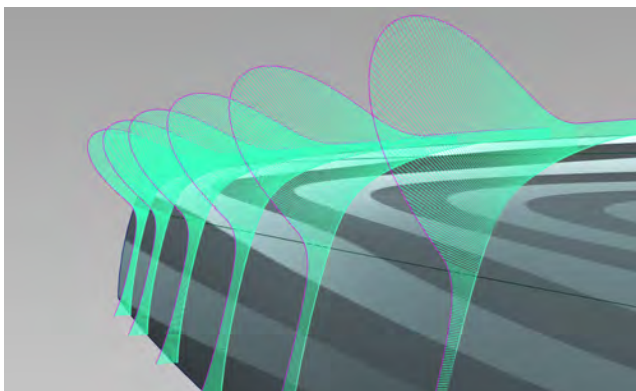

# Technical What's New

## Improvements in CV Selection and Movement

Since direct manipulation of control vertices (CVs) is key for modern surface development, improvements have been made to the CV selection functionality and to the behavior of movement, which is now more controllable and predictable in terms of direction, speed, and mouse sensitivity. The CV selection region (PickBox size) and manipulators have been increased to improve visibility, making it easier to pick and move a CV.

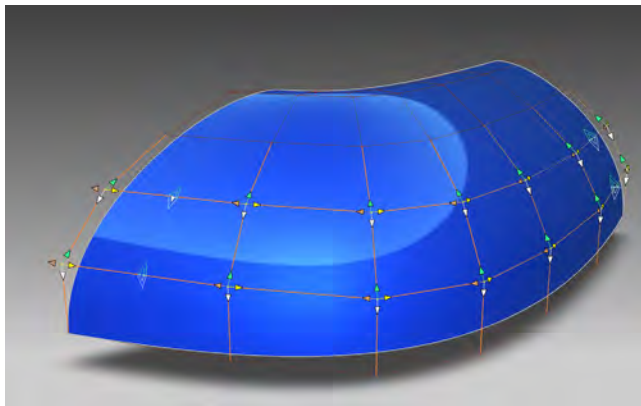

## Vector Options within Project and Trim Tools

You can now define the projection vector from within the Project tool using the Vector Options, in the same way as with the Align or Draft tool. Using this method, you do not have to change the view, or create a vector construction object before entering the Project tool. This option saves substantial time for users who mainly want to work in only the orthogonal window.

## Curve Fit by Projection

New curve-fit options have been added to the project tool for situations when the projection should be a real 3D curve instead of a Curve on Surface. These new options provide more customized workflows for Class-A modeling where it is essential to strictly work with single segmented/light surfaces.

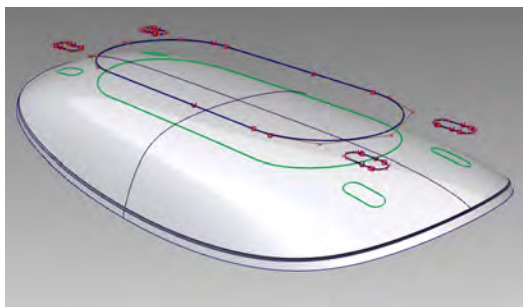

## Evaluation

### New Editor for Creating Cross Sections

All cross-section functionality has been consolidated within a single window, providing a consistent workflow for creating and managing cross sections.

The new editor window provides all of the previous options from the evaluation and visual cross-sections tools. Additional enhancements include support of measurement tools, snapping functionality, and the use of construction planes to create planar sections. Plus, all visual cross sections can now be promoted as real 3D curves.

A new Global option is available for automatically creating visual sections for all visible geometry in the scene. This feature is especially helpful when creating new geometry, as significant design time can be saved since the cross section doesn't have to be applied each time.

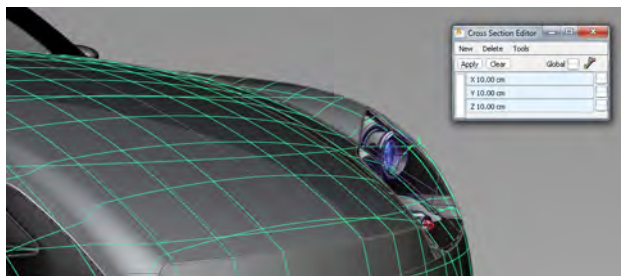

### New Pedestrian Protection Evaluation Tool

This tool (Evaluate > Pedestrian Protection) allows a car designer to evaluate pedestrian impact with a car hood. By knowing where the head impacts the hood, the design can be modified to reduce collisions with stiff under-structures. The evaluation is based on pedestrian height, width of impact zone, ground height, and car hood surfaces to accommodate country-specific standards.

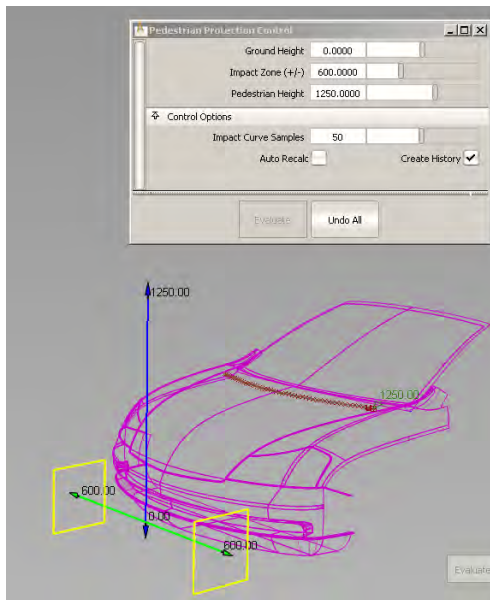

# Technical What's New

## Data Transfer

### Option to Output Log File for IGES Import/Export

A log file contains a list of path names for imported/exported file(s) and a list of warning and/or error messages. It is generated when exporting or importing an IGES file. In the past, the creation of the log file often caused an error with the file storage location. In Alias 2011, there is now an option to turn the log file creation "off" to save storage space.

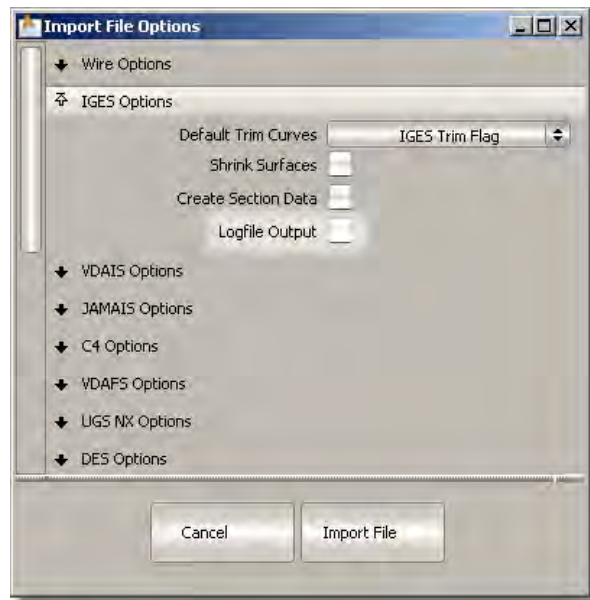

### Autodesk DirectConnect

Autodesk DirectConnect 2011 will now offer CATIA 4 and CATIA 5 translators free of charge.

## Learn More

### Stay Up to Date

Autodesk offers you more. Gain access to technical expertise, utilize training and support programs direct from Autodesk, stay up to date with the latest product releases, and give us your feedback. Not only does Autodesk want to help you use the Autodesk Alias line of products more effectively but also make sure our products are working effectively for you.

### Autodesk Subscription

Autodesk® Subscription gives you immediate access to software upgrades and exclusive access to service and support benefits designed to help you get the most out of your Autodesk software. Learn more at [www.autodesk.com/subscription](http://www.autodesk.com/subscription).

### Feedback

We appreciate your feedback and feel that it is crucial to making the Alias family of products the best they can be to meet your needs. We look forward to receiving your comments. Autodesk Alias customers can interact with the Autodesk Alias development team through several avenues such as:

- Provide tips or join newsgroups at [aliasdesign.autodesk.com](http://aliasdesign.autodesk.com)
- Keep up to date on what is happening in your industry, stay in touch with other industry professionals, and take advantage of a host of online resources at the Autodesk Alias Design Community Portal at [aliasdesign.autodesk.com](http://aliasdesign.autodesk.com)
- Talk with your Autodesk Authorized Reseller and support staff

## Conclusion

We thank you for your continued support of the Autodesk Alias product line—Autodesk Alias Design, Autodesk Alias Design for Inventor, Autodesk Alias Surface, and Autodesk Alias Automotive—and hope you feel we are listening to your needs. We hope that the new and enhanced product functionality will help make you more productive, make your company more competitive, and return true value to your bottom line.

### Features at a Glance

The following table indicates by product the new and enhanced features in the 2011 release.

# Technical What's New — Features at a Glance

Feature	Alias Design	Alias Surface	Alias Automotive	Alias Design for Inventor
<b>General Improvements</b>				
System Diagnostics	X	X	X	
Nonproportional View and Dolly Interaction	X	X	X	
Additive Selection Mode	X	X	X	
Selection on the Interior of Surfaces	X	X	X	
<b>Visualization</b>				
Anti-alias Setting Changes	X	X	X	
Improved Edge Display	X	X	X	
Improved Ambient Occlusion Workflow	X	X	X	
Surface Continuity Locator Enhancements	X	X	X	
<b>Modeling</b>				
Improved Fit Curve Tool	X	X	X	
Offsetting Surfaces with Unified Normals	X	X	X	
G3 Continuity		X	X	
Improvements in CV Selection and Movement	X	X	X	
Vector Options within Project and Trim Tools	X	X	X	
Curve Fit by Projection	X	X	X	
<b>Evaluation</b>				
New Editor for Creating Cross Sections		X	X	
Pedestrian Protection Evaluation Tool			X	
<b>Data Transfer</b>				
Option to Output Log File for IGES Import/Export	X	X	X	
Autodesk DirectConnect	X	X	X	
<b>Freeform Shape Editing</b>				
Edit Form				X
Duplicate Edit Form				X
Shape Edge				X
Form Symmetry				X
Transform Edge-Patch				X
Planarize Edge				X
Update Form				X
Quit Alias				X

## Specialized Design Tools

Bring your ideas to life. Build conceptual product models and create high-quality surfaces with a comprehensive set of digital modeling, shape definition, painting, and sketching tools.

### Autodesk Alias Design

Autodesk Alias Design software is for consumer product designers who control the entire design process—from ideation to the final surfaces that are passed to engineering. Rapidly develop and communicate product design concepts using sketches, 3D product models, illustrations, photorealistic renderings, and animation.

### Autodesk Alias Design for Inventor

Engineers can take advantage of Alias Design capabilities with Autodesk Alias Design for Inventor. This version was built specifically for Inventor users to provide integrated freeform shape modeling capabilities directly within the Inventor environment.

### Autodesk Alias Surface

Autodesk Alias Surface software offers a full set of dynamic 3D surface modeling capabilities that enable virtual modelers to evolve concept models and scan data into high-quality production surfaces for consumer product design and Class-A surfaces for automotive design and styling.

### Autodesk Alias Automotive

Autodesk Alias Automotive software is an industry-leading application for automotive design and styling and the choice of leading automotive styling studios throughout the world. The software provides a comprehensive set of visualization and analysis tools for the entire shape-definition process, from concept sketches through Class-A surfacing.

To learn more, visit:

[www.autodesk.com/aliasfamily](http://www.autodesk.com/aliasfamily).