



Autodesk®
for the Building Products
and Fabrication Industry

Make Digital Prototyping Your Competitive Advantage!

Design, visualize, and simulate your products digitally, and collaborate with customers in the Building Information Modeling (BIM) process to win more business with greater cost savings.

Common challenges faced by manufacturers of building components:

- Balancing increasing building performance and quality expectations against lower costs while driving increasingly complex design and construction processes
- Seeking new ways to get a leg up against competitors in winning project bids
- Improving collaboration with architects, engineers, and builders to have a better understanding of design intent and product information
- Assist builders and subcontractors in improving the quality and efficiency of their construction, installation, and maintenance processes
- Respond to increasingly stringent regulatory pressure and sustainability requirements driven by elevated environmental consciousness

Industry Challenges

Building product manufacturers and fabricators operate in a complex and demanding environment and face unprecedented challenges today. They are simultaneously confronted with increasing global competition for new project opportunities, shorter project delivery schedules, improving quality while managing cost, and the need to increase the level of collaboration with their customers in the Building Information Modeling (BIM) process.

To meet these challenges, manufacturers and fabricators must engage with customers during the planning, design, and engineering phases of projects. Additionally, the need to accelerate innovation is essential for market success, while managing quality and costs is critical to the bottom line. Successful manufacturers must effectively collaborate with both local and global project development teams and supply chain partners in order to develop and deliver more complex

products in less time as well as meet increasingly stringent regulations and customer sustainability requirements driven by elevated environmental consciousness. The challenges do not end with product and project development; the ability to introduce designs into flexible manufacturing facilities can make or break the success of a project.

Strategies for Success

Succeeding in this market requires an intense focus on meeting customer needs. Establishing a design and engineering methodology that effectively meshes with customers' processes is critical to success. Driving new business and rapidly responding to customers require eliminating inefficiencies throughout the design and development processes. From initial concept development and bid proposal through project delivery and post-sales support, efficiently meeting customer demands can mean the difference between success and failure.

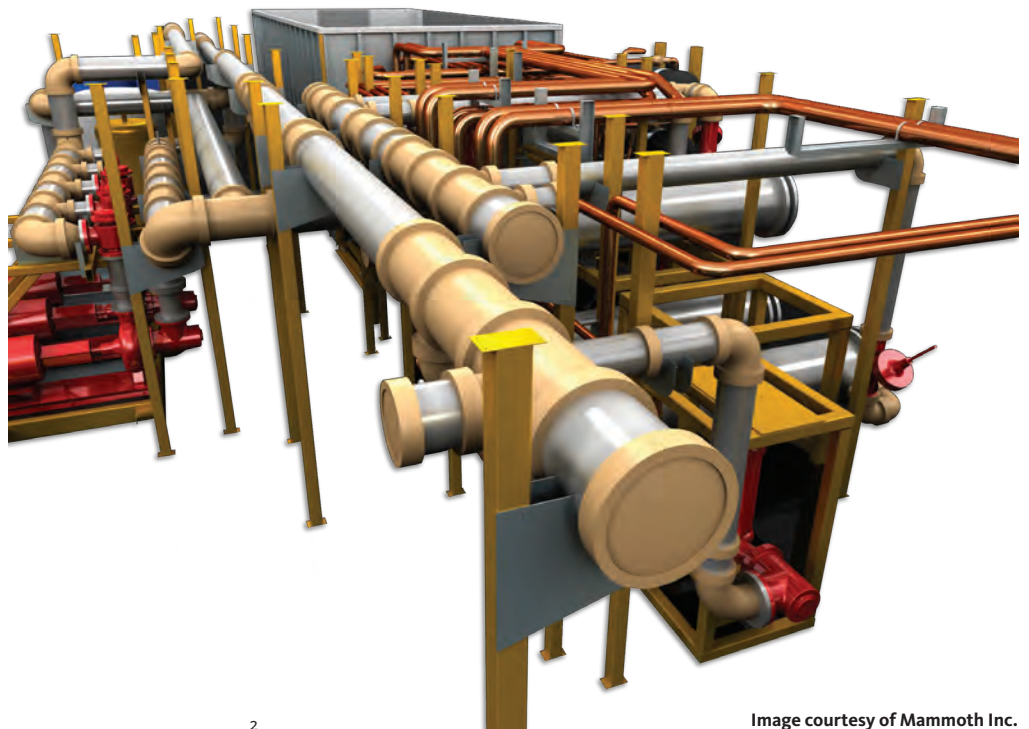



Whether a new product platform, custom project, or a derivative of existing designs, development teams need the ability to explore a design early in the process and communicate that design with stakeholders and customers. The ability to design, visualize, and simulate a project from the earliest concept phase is a prerequisite to avoiding costly design errors that may not appear until the project is in production. Just as important is the ability for multiple disciplines to communicate and collaborate throughout the development process, without recreating data to meet their needs.

The Autodesk Solution for Digital Prototyping

Autodesk® has a proven track record of helping manufacturers go beyond 3D design to Digital Prototyping with Autodesk® Inventor® software. The Autodesk solution for Digital Prototyping brings together design data from all phases of the development process into a single digital model created in Inventor. Developing a complete and accurate digital prototype gives manufacturers of building products, equipment, and custom-fabricated components the ability to:

- Design, visualize, and simulate products digitally before they are built.

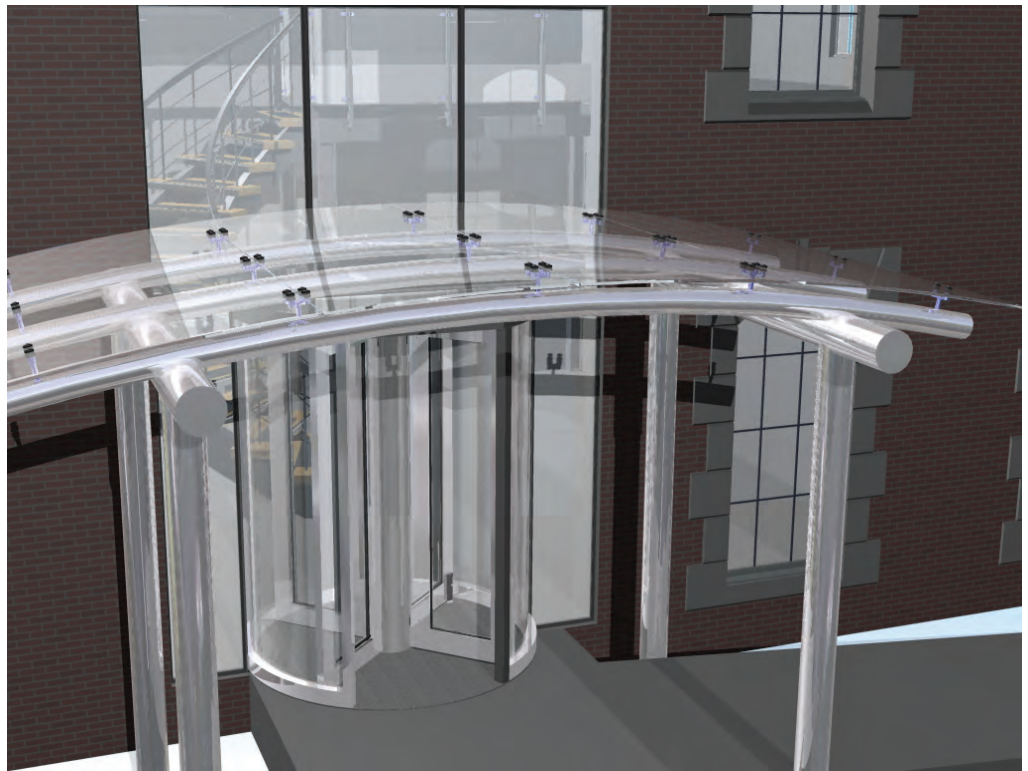

- Effectively communicate and collaborate with architects, engineers, and builders who use a BIM process.
- Win more customers and project bids.
- Enable design decisions to be made earlier in the design process, resulting in greater cost savings.



Digital Prototyping, combined with Autodesk’s leadership in BIM, uniquely positions Autodesk to deliver an integrated workflow that enables better productivity, predictability, and control throughout the life of the project. This integrated workflow is changing the way manufacturing and architectural companies think about their design practices and is helping them build better products faster, with greater confidence and fewer costs. Unlike other vendors, Autodesk is the only company that can offer these capabilities in a way that is truly scalable, attainable, and cost effective for manufacturers, architects, engineers, and builders.

Sales and Marketing

In an increasingly competitive and global market, suppliers and fabricators in the construction industry need to be flexible and respond quickly to new opportunities. The Autodesk solution for Digital Prototyping lets you hit the ground running in generating new business—and responding to customer needs quickly and accurately, creating competitive bids and proposals for new work with peace of mind.

Autodesk provides manufacturers and fabricators with the tools they need to create stunningly realistic and interactive digital prototypes of the end product that can be used to demonstrate value in a unique and compelling way before actually building anything.

Autodesk® Inventor® enables manufacturers to easily create and publish simplified 3D representations of product models, associated intelligent connection points, and other product information into file formats that can be opened by Autodesk Revit, AutoCAD® Architecture, and AutoCAD® MEP products. By providing “BIM-ready” product models that can be directly incorporated into the building design and construction process, manufacturers not only meet customer bid requirements, but are more likely to have their products specified and selected, and at an earlier stage, by architects, engineers, and builders.

Autodesk® Vault data management tools provide secure access to all essential design information, supporting rapid, accurate bid preparation. With advanced search tools, detailed design copy rules, bill of material (BOM) management, change impact analysis, and detailed rollup of attributes such as weight, cost, and so on., Autodesk software helps simplify the bid process and make it far more accurate.

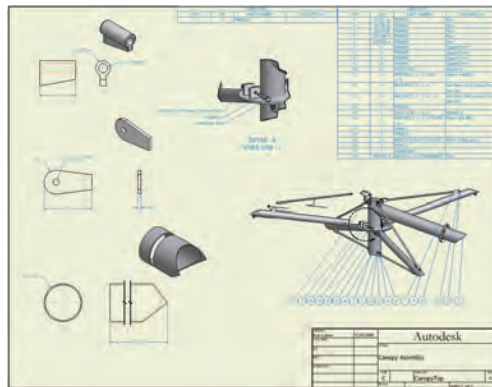
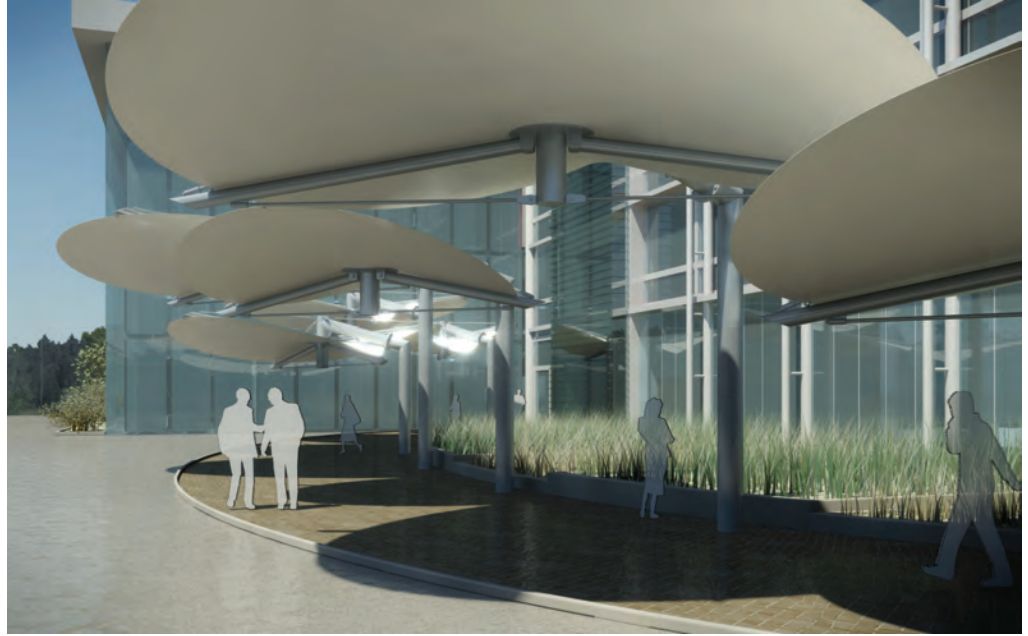

Autodesk® Showcase® allows manufacturers to repurpose Inventor model data to create stunning visual representations. By creating realistic and compelling visualizations, manufacturers can enhance the ability of their customers to understand design and product proposals, quickly and efficiently.

Autodesk's family of Revit® products, purpose built for BIM, helps manufacturers and fabricators extract detailed takeoffs and estimates that allow a more accurate bid or quote to be generated for the project at hand. Manufacturers can also rely on Revit to validate product designs and proposals within the context of the building and ensure compliance with the design intent.

Autodesk Seek allows manufacturers to market their products through an online channel that reaches a large community of architects, engineers, and building designers potentially interested in their products. And because the manufacturers' product designs can be directly incorporated into the building model, manufacturers have an advantage in getting their products specified and selected earlier in a building project.



Design and Engineering

Building product manufacturers and fabricators must continually innovate to deliver on complex projects that set high standards for reliability, quality, and performance. With the Autodesk solution for Digital Prototyping, they can overcome the unique challenges of designing and engineering products and projects by coordinating and evaluating design configurations—before they are physically manufactured.

By generating engineering and manufacturing documentation directly from the 3D model, the manufacturer can combine the benefits of associative drawing views with the power and widespread acceptance of the AutoCAD DWG™ file format to deliver the project in less time with fewer errors. Autodesk's world-class, interoperable Digital Prototyping and BIM solutions enable manufacturers, architects, engineers, and builders to collaborate more effectively. By sharing digital information, manufacturers and builders can better communicate and realize the design intent of the project.

Autodesk Inventor enables designers and engineers to develop complete digital prototypes for testing and validation long before the product is built. Inventor's intuitive parametric design environment enables manufacturers to rapidly generate multiple iterations of a digital prototype to meet changing architectural and contractor requirements. Inventor provides integrated data management tools that allow design workgroups to manage and track all the design components of a digital prototype and helps them to better reuse critical design data, manage BOMs, and promote earlier collaboration.

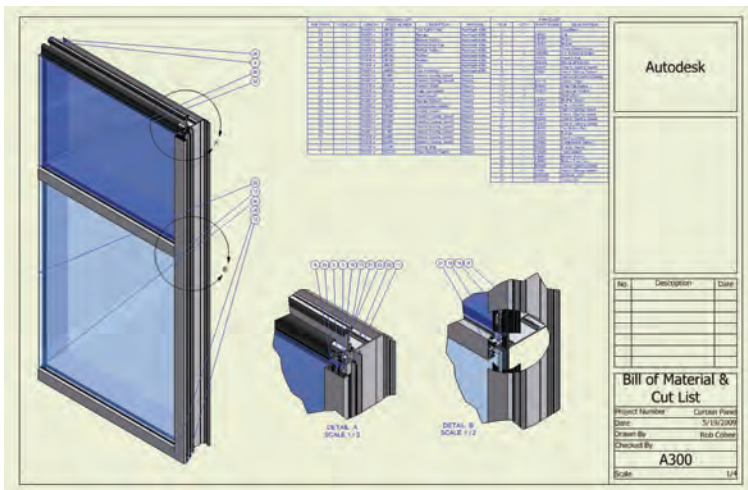

Autodesk® Navisworks® helps manufacturers and fabricators coordinate with trade partners to more fully understand and inform them of the coordination and collaboration issues that will need to be addressed during the project delivery cycle.

Manufacturing/Fabrication

Getting products and projects to market quickly has become increasingly important for building product manufacturers and fabricators. With shrinking market windows and ballooning customer demands, the need to synchronize product design with manufacturing processes for delivery of high-quality products is greater than ever.

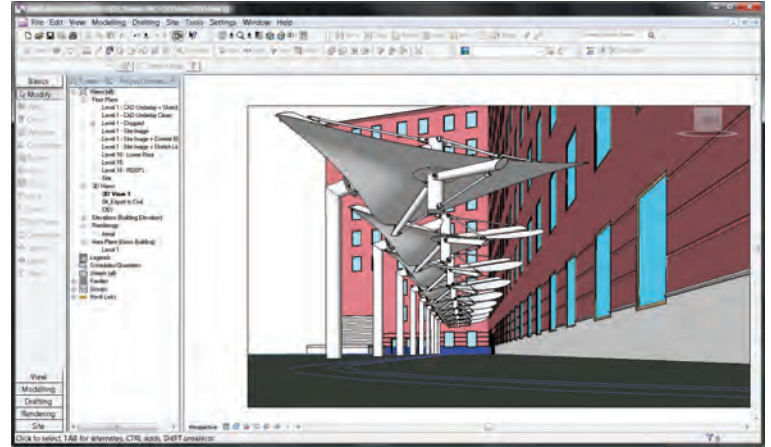

Autodesk offers tools that help manufacturers deliver high-quality products on time and under budget. The close integration between Autodesk Inventor, Autodesk Revit, and AutoCAD allows fabricators and building design professionals to easily work together and share design information within a seamless workflow. This improved collaboration removes a major source of design errors, ensures that designs are fully coordinated, and eliminates the need for redrawing and/or modeling.

Autodesk Inventor includes powerful documentation capabilities and native support of the DWG file format, helping manufacturers create and share designs, shop floor drawings/ submittals, and fabrication drawings more intuitively and efficiently. Inventor's built-in iLogic technology provides designers and engineers with a programmatic, rules-based approach to automatically generate product configurations—reducing tedious repetitive tasks and increasing overall design productivity.

Autodesk® Design Review enables manufacturers to easily and efficiently review, annotate, and compare 2D and 3D models and conduct shop drawing reviews in collaboration with architects, engineers, and construction professionals—resulting in shorter review cycles, review of more complete information, and reduced costs. This information occurs in a secure environment that protects intellectual property rights, irrespective of the original design creation software.

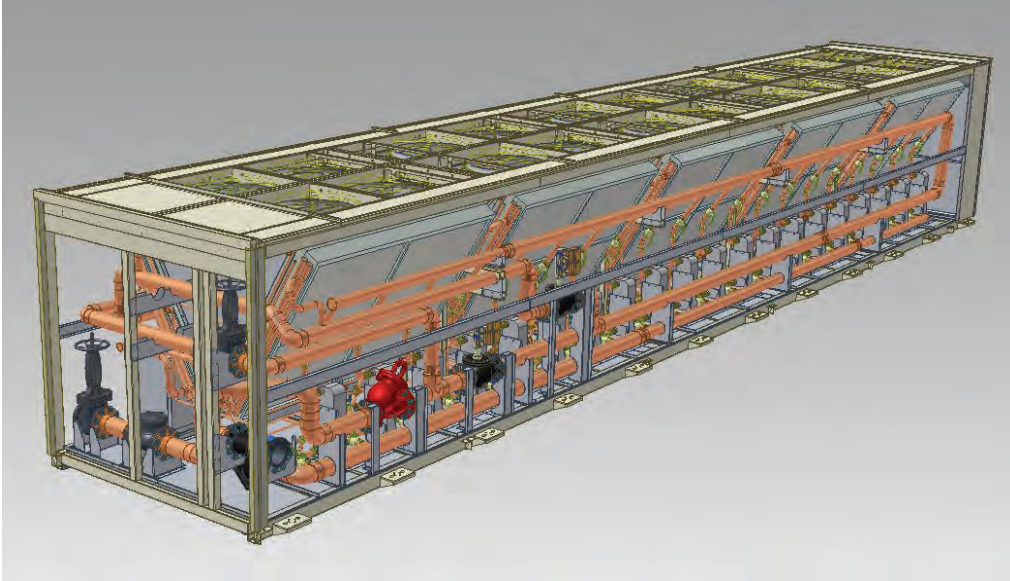

Image courtesy of Mammoth Inc.

Building Installation/Integration

Customers need the critical information to allow them to install and maintain products, equipment, and systems in today's increasingly complex buildings. Building product manufacturers are able to meet their customers' needs by maintaining this information in digital models. The Autodesk solution for Digital Prototyping lets you embed the critical information and metadata needed for installation and maintenance into the digital model, which can be used to develop installation animations, exploded views, part diagrams, and other helpful information to meet customers' needs.

Autodesk brings Digital Prototyping and BIM information and processes together. This enables building component manufacturers to outline installation, commissioning, and maintenance activities. This information can be provided as metadata within the digital model.

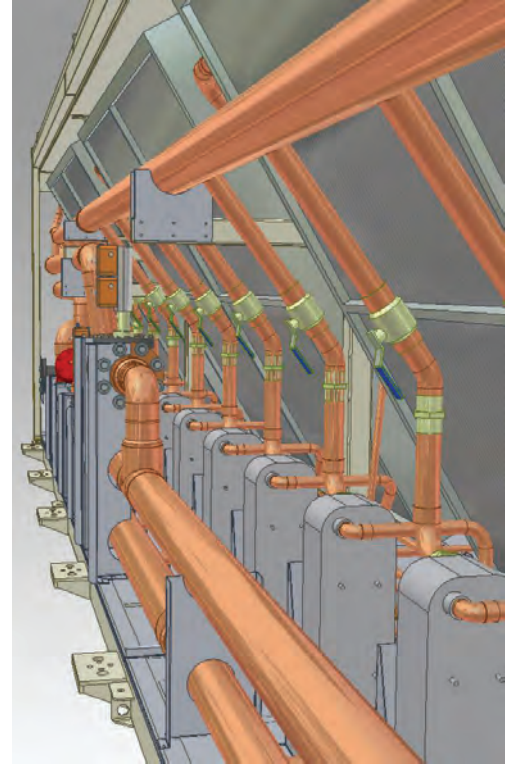
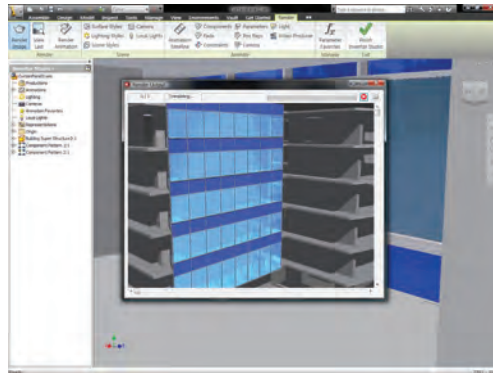
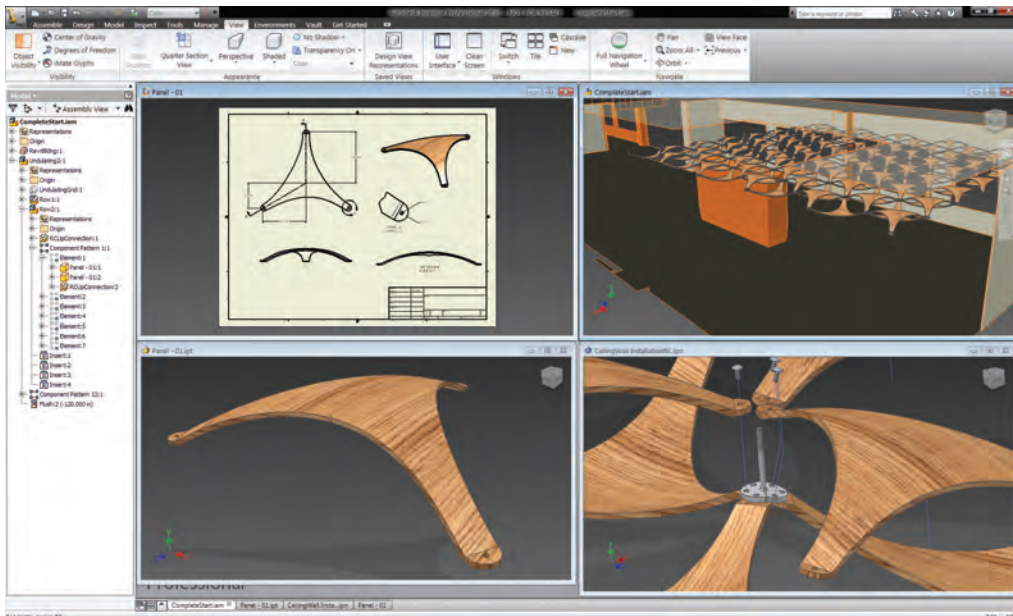

Image courtesy of Mammoth Inc.

Autodesk Inventor's integrated simulation tools make it possible for building component manufacturers to more completely understand longer term operational maintenance requirements of products and equipment. Because these tools are part of the design environment, it is practical and cost-effective to employ simulation throughout the design process.

Autodesk's wide range of simulation tools, including **Autodesk Algor**, enables engineers to easily evaluate different potential solutions for a wide range of engineering issues, allowing them to make the best design decisions.



Autodesk Navisworks enables design, engineering, and construction teams across trades to unite contributions into a single collaboration model. Fully interoperable with other Autodesk solutions, Navisworks enables manufacturers to collaborate directly with specialty and general contractors to visualize, simulate, and analyze their models in the context of the project.

Customer References

“Inventor enables us to produce a full working model, which we can rotate to show all aspects. We can demonstrate to the customer how the new design will fit to replace the old escalator or existing staircase. This helps give the customer confidence in what we are doing. They no longer have to try and interpret drawings, they can actually see what we are hoping to do and discuss it with us there and then.”

—Brian White
Technical Author
KONE Escalators



“Once we’ve finished a model, we can optimize, cost, and order materials before the job hits the shop floor. Inventor helps us reduce material costs and waste.”

—Stefan Purcell
CAD Draftsman
Urban Art Projects



“I’m not sure how we’d even begin to tackle a project of the size of the Thirty Meter Telescope without Inventor—the resources required would just be overwhelming.”

—Craig Breckenridge
Drawing Office Manager
Dynamic Structures



“The ability to use digital prototyping to virtually explore a complete product before it is built saves us time at every step of the product development cycle, from the industrial design phase through the manufacturing process.”

—Christian Sperka
Chief Information Officer
Franke

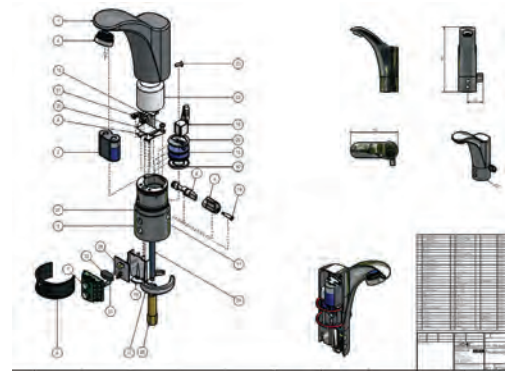

“Autodesk Inventor effectively handled our assemblies of 10,000 parts and addressed our sheet metal requirements—plus, with Autodesk Inventor, AutoCAD compatibility was a given.”

—Matt McFarland
Senior Designer
Mammoth, Inc.

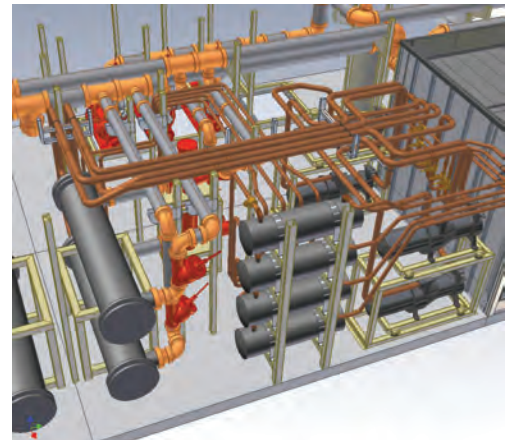

Digital Prototyping for the Manufacturing Market

Autodesk is a world-leading supplier of engineering software, providing companies with tools that help them experience their ideas before they are real. By putting powerful Digital Prototyping technology within the reach of mainstream manufacturers, Autodesk is changing the way manufacturers think about their design processes and is helping them create more productive workflows. The Autodesk approach to Digital Prototyping is unique in that it is scalable, attainable, and cost-effective, which allows a broader group of manufacturers to realize the benefits with minimal disruption to existing workflows, and provides the most straightforward path to creating and maintaining a single digital model in a multidisciplinary engineering environment.

Learn More or Purchase

Access specialists worldwide who can provide product expertise, a deep understanding of your industry, and value that extends beyond your software purchase. To purchase Autodesk® software contact an Autodesk Premier Solutions Provider or Autodesk Authorized Reseller. Locate a reseller near you at www.autodesk.com/reseller.

Autodesk Learning and Education

From instructor-led or self-paced classes to online training or education resources, Autodesk offers learning solutions to fit your needs. Get expert guidance at an Autodesk Authorized Training Center (ATC®) site, access learning tools online or at your local bookstore, and validate your experience with Autodesk certifications. Learn more at www.autodesk.com/learning.

Autodesk Services and Support

Accelerate return on investment and optimize productivity with innovative purchase methods, companion products, consulting services, and support from Autodesk and Autodesk authorized partners. Designed to get you up to speed and keep you ahead of the competition, these tools help you make the most of your software purchase—no matter what industry you are in. Learn more at www.autodesk.com/servicesandsupport.

Autodesk Subscription

Autodesk® Subscription gives you immediate access to software upgrades and exclusive access to service and support benefits designed to help you get the most out of your Autodesk software. Learn more at www.autodesk.com/subscription.

This brochure is printed on 100 percent postconsumer waste recycled paper.

Autodesk, AutoCAD, Alias, DWF, Autodesk Inventor, Moldflow, Navisworks, Productstream, Showcase, Sketch-Book, Vault are registered trademarks or trademarks of Autodesk, Inc., and/or its subsidiaries and/or affiliates in the USA and/or other countries. All other brand names, product names, or trademarks belong to their respective holders. Autodesk reserves the right to alter product and services offerings, and specifications and pricing at any time without notice, and is not responsible for typographical or graphical errors that may appear in this document. © 2010 Autodesk, Inc. All rights reserved.