

Notice to Autodesk Inventor Customers: TS1110647 Released

In our continuing efforts to provide high quality products, Autodesk has released hotfix TS1110647 which addresses an issue where Inventor 2011 unexpectedly exits on feature creation.

This document contains the latest information regarding the installation and use of this update. It is strongly recommended that you read this entire document before you apply the update to your product. For reference, you should save this document to your hard drive or print a copy.

Contents

- [Description of the Issue](#)
- [System Requirements](#)
- [Installation Instructions](#)

[Return to Top](#)

Description of the Issue

A small percentage of users may encounter conditions where Inventor 2011 exits unexpectedly when Direct Manipulation commands are employed. This issue is linked to use of the OK/CANCEL buttons (see picture below) from the Direct Manipulation mini-toolbar (the command options displayed in the Inventor graphics area). This uncommon error is unrelated to specific machine configurations. This Hotfix corrects this condition.

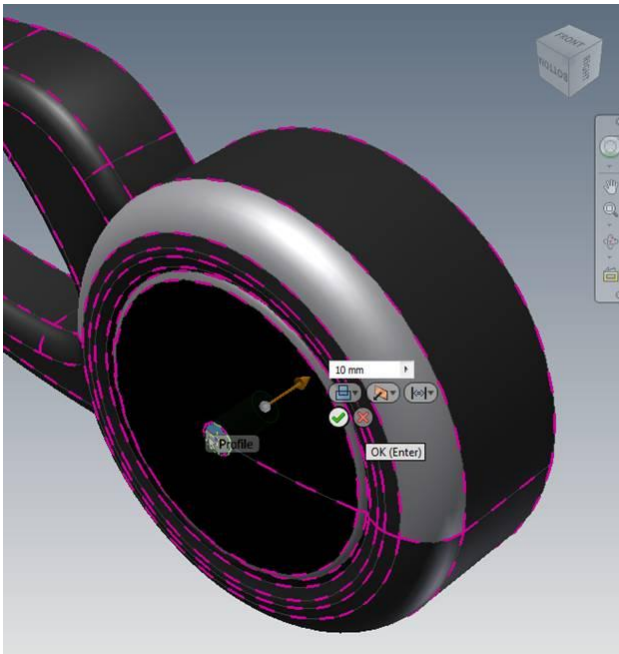

[Return to Top](#)

System Requirements

For application of this hotfix, your system must have one of the following products installed:

- AutoCAD® Inventor® Professional Suite 2011
- AutoCAD® Inventor® Routed Systems Suite 2011
- AutoCAD® Inventor® Simulation Suite 2011
- AutoCAD® Inventor® Suite 2011
- AutoCAD® Inventor® Tooling Suite 2011

[Return to Top](#)

Installation Instructions

This hotfix is available in 32bit and 64bit versions (downloaded together as one bundle) and is only applicable to Autodesk Inventor 2011. Once installed, it will appear as an update under Add/Remove Programs and can be uninstalled from there.

1. Download hotfix TS1110647.zip for Autodesk Inventor 2011.
2. Extract TS1110647_32-bit.msp and TS1110647_64-bit.msp from the zip file downloaded in step 1.
3. Double click on the appropriate .msp file (32-bit or 64-bit) to install this hotfix on each system running Autodesk Inventor 2011.
4. Chose Next to begin the install...
5. Once finished you'll receive the Autodesk Inventor 2011 Setup dialog box stating that the update has been successfully applied.
6. Click Finish to complete the installation and exit the dialog box.

[Return to Top](#)

Thank You...

We thank all our customers who identified this issue and reported it to us. These reports give us the opportunity to improve the product and provide you with the best solution in mechanical design. We also thank you for your continued business and for feedback regarding the content of this update release.

Respectfully,

Autodesk Inventor Product Team

[Return to Top](#)