

Autodesk® Topobase™ Gas User Guide

Autodesk® Topobase™ Gas User Guide

Autodesk®

© 2009 Autodesk, Inc. All Rights Reserved. Except as otherwise permitted by Autodesk, Inc., this publication, or parts thereof, may not be reproduced in any form, by any method, for any purpose.

Certain materials included in this publication are reprinted with the permission of the copyright holder.

Trademarks

The following are registered trademarks or trademarks of Autodesk, Inc., in the USA and other countries: 3DEC (design/logo), 3December, 3December.com, 3ds Max, ADI, Alias, Alias (swirl design/logo), AliasStudio, AliasWavefront (design/logo), ATC, AUGI, AutoCAD, AutoCAD Learning Assistance, AutoCAD LT, AutoCAD Simulator, AutoCAD SQL Extension, AutoCAD SQL Interface, Autodesk, Autodesk Envision, Autodesk Insight, Autodesk Intent, Autodesk Inventor, Autodesk Map, Autodesk MapGuide, Autodesk Streamline, AutoLISP, AutoSnap, AutoSketch, AutoTrack, Backdraft, Built with ObjectARX (logo), Burn, Buzzsaw, CAiCE, Can You Imagine, Character Studio, Cinestream, Civil 3D, Cleaner, Cleaner Central, ClearScale, Colour Warper, Combustion, Communication Specification, Constructware, Content Explorer, Create>what's>Next> (design/logo), Dancing Baby (image), DesignCenter, Design Doctor, Designer's Toolkit, DesignKids, DesignProf, DesignServer, DesignStudio, DesignStudio (design/logo), Design Web Format, Discreet, DWF, DWG, DWG (logo), DWG Extreme, DWG TrueConvert, DWG TrueView, DXF, Ecotect, Exposure, Extending the Design Team, Face Robot, FBX, Filmbox, Fire, Flame, Flint, FMDesktop, Freewheel, Frost, GDX Driver, Gmax, Green Building Studio, Heads-up Design, Heidi, HumanIK, IDEA Server, i-drop, ImageModeler, iMOUT, Incinerator, Inferno, Inventor, Inventor LT, Kaydara, Kaydara (design/logo), Kynapse, Kynogon, LandXplorer, LocationLogic, Lustre, Matchmover, Maya, Mechanical Desktop, Moonbox, MotionBuilder, Movimento, Mudbox, NavisWorks, ObjectARX, ObjectDBX, Open Reality, Opticore, Opticore Opus, PolarSnap, PortfolioWall, Powered with Autodesk Technology, Productstream, ProjectPoint, ProMaterials, RasterDWG, Reactor, RealDWG, Real-time Roto, REALVIZ, Recognize, Render Queue, Retimer,Reveal, Revit, Showcase, ShowMotion, SketchBook, Smoke, Softimage, Softimage|XSI (design/logo), SteeringWheels, Stitcher, Stone, StudioTools, Topobase, Toxik, TrustedDWG, ViewCube, Visual, Visual Construction, Visual Drainage, Visual Landscape, Visual Survey, Visual Toolbox, Visual LISP, Voice Reality, Volo, Vtour, Wire, Wiretap, WiretapCentral, XSI, and XSI (design/logo).

The following are registered trademarks or trademarks of Autodesk Canada Co. in the USA and/or Canada and other countries: Backburner,Multi-Master Editing, River, and Sparks.

The following are registered trademarks or trademarks of MoldflowCorp. in the USA and/or other countries: Moldflow, MPA, MPA (design/logo),Moldflow Plastics Advisers, MPI, MPI (design/logo), Moldflow Plastics Insight,MPX, MPX (design/logo), Moldflow Plastics Xpert.

All other brand names, product names or trademarks belong to their respective holders.

Disclaimer

THIS PUBLICATION AND THE INFORMATION CONTAINED HEREIN IS MADE AVAILABLE BY AUTODESK, INC. "AS IS." AUTODESK, INC. DISCLAIMS ALL WARRANTIES, EITHER EXPRESS OR IMPLIED, INCLUDING BUT NOT LIMITED TO ANY IMPLIED WARRANTIES OF MERCHANTABILITY OR FITNESS FOR A PARTICULAR PURPOSE REGARDING THESE MATERIALS.

Published by:
Autodesk, Inc.
111 McInnis Parkway
San Rafael, CA 94903, USA

Contents

Chapter 1	Autodesk Topobase Gas User Guide	1
	Introduction	1
	Using Gas Workflows	2
	Initiate a Gas Workflow	2
	Acquisition Workflows	3
	Network Point Creation	3
	Network Pipe Creation	5
	Network Pipe with Fitting Point Creation	6
	House Connection Creation	7
	Site or Facility Creation	8
	Facility Creation	9
	Damage Creation	10
	Pressure Zone Creation	11
	Protection Creation	12
	Administrative Information Creation	12
	Analysis Workflows	13
	Find Connected	13
	Find Connected with Stop Conditions	15
	Find Non Split Point on Pipe	17
	Cable Acquisition Workflows	18
	Control Cable Creation	18
	Control Point Creation	19
	Report Workflows	19
	Report Generation	20

Managing Gas Network Topologies	20
Check Topologies	21
Explore Stop Conditions	22
Use Gas Feature Functions	22
Maintenance Record Creation	23
Marker Creation	24
Show Input and Output Pipes	24
Show Connected Pipes	25
Connect a Point to a Site	25
Remove Connections from a Site	26
Network Tracer	26
Connect Features to a Zone	27
Use a Reference Record	28
Split Lines	29
Soft Split and Hard Split	30
Extract Points from Lines	32
Organization of Gas Functions and Features	34
Explore Gas Feature Rules	34
Feature Rule: Set Pressure Zone	35
Feature Rule: Set Supply Zone	37
Feature Rule: Create Start and End Nodes	38
Administration	39
Contact	39
Location	40
Manufacturer	40
Meter Area	40
Pressure Zone	41
Supply Zone	42
Gas Model Feature Classes	42
Control Cable	45
Control Cabinet	45
Control Cable	46
Control Cable Point	46
Facility	46
Miscellaneous	48
Maintenance	48
Marker	48
Terrain Point	49
Pipe	49
Pipe Feature Class Form	49
Pipe	50
Damage Point	52
Point	52
Point Feature Class Form	54
Connect Point Features to Sites	54
Armature	55

Blow Off Valve	56
Fill	56
Filter	56
Fitting	57
House Connector	57
Light	59
Meter	59
Odor Equipment	60
Pig Launch	60
Pump	61
Regulator	61
Reservoir	62
Sample	62
Shut Off Valve	63
Siphon	63
Source	64
Tank	64
Valve	65
Profile	65
Protection	65
Anode	66
Anode Station	66
Casing	67
Site	67
Understand and Work with the Gas Data Model	68
Explore the Gas Data Model	70
Gas Topologies	71
Define Labels	72
Glossary	73
Index	79

Autodesk Topobase Gas User Guide

1

Introduction

Autodesk® Topobase™ Gas allows gas utilities to use CAD tools to document, maintain, and present gas networks and infrastructure. In the process, gas utilities create information that contains attribute data associated with their assets — such as pumps, meters, and valves. Engineering design information is GIS-ready, incorporating a dynamic utility model that enables on-the-fly topology and analysis, such as network traces. Gas utilities can then maintain their infrastructure data in the Topobase Gas enterprise solution built on an Oracle database, which can be accessed across the organization and used by business teams in ongoing network and asset management.

Topobase Gas comes with a gas-specific data model comprised of the most commonly requested and used gas-specific data schemas, object relationships and associations, business rules, and workflows. Each area is customizable to fit specific needs.

Topobase Gas workflows are designed to streamline common activities related to creating and maintaining gas utility networks. Designers can rely on the extensive library of workflows to perform their daily tasks — without needing to understand the entire data model.

Generally, the data model delivered with Topobase Gas is customized to meet customer or project requirements in different countries and regions. This customization impacts feature class form layout, additional functions, the content of domains, and available reports. This guide describes basic functionality, not specific customizations.

Using Gas Workflows

An important feature of Topobase Gas is that designers have the ability to establish a comprehensive set of workflows. Workflows streamline business processes based on the gas utility's current way of doing business. Workflows help guide you through common tasks and govern the way information is entered into the database. Workflows — and related business rules that are working behind the scenes — also prevent designers from leaving out required elements, choosing incorrect materials, or including incorrect material sizes, thereby reducing errors during design and data updates.

Topobase Gas provides four types of predefined workflows:

Workflow Type	Definition
Acquisition Workflow	Create network points, pipes, house connectors, sites, facilities, pressure zones, and so on.
Analysis Workflow	Find connected pipes and trace the network from a designated start and stop point.
Cable Acquisition Workflow	Create control cables and points.
Report Workflow	Generate and print predefined and customized reports and export the report into HTML, ASCII, or PDF files.

You can also create your own workflows.

For more information about defining and managing workflows, refer to Administration Introduction in the Topobase Administrators Guide.

Initiate a Gas Workflow

Before starting a workflow, you must make sure you've set a display model and generate graphics. Report workflows can be used without a drawing.

You can also start workflows from the shortcut menu of the related feature class.

To generate graphics and start a workflow

- 1 On the ribbon, click Home tab ► Display panel ► Display Model and do one of the following:
 - Click the arrow button and select a previously opened display model.

- Click Open Display Model and select a display model (.tbdm file).
- Select Open Default Display Model.

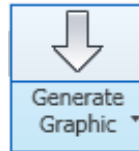

- 2 Click Generate Graphic.
- 3 In the Topobase Task Pane, click the Workflow explorer icon to display

the workflows.



- 4 In the Workflows group, select a workflow and click Execute.
Optionally, you can right-click a workflow and click Execute or simply double-click a workflow.

Acquisition Workflows

Acquisition workflows and rules help designers create features like valves, network points, pipes, meters, house connections, and so on. Acquisition workflows are also used to remove features like house connections and pips in a gas network.

Network Point Creation

Use the Network Point Creation workflow to create any of the network point types.

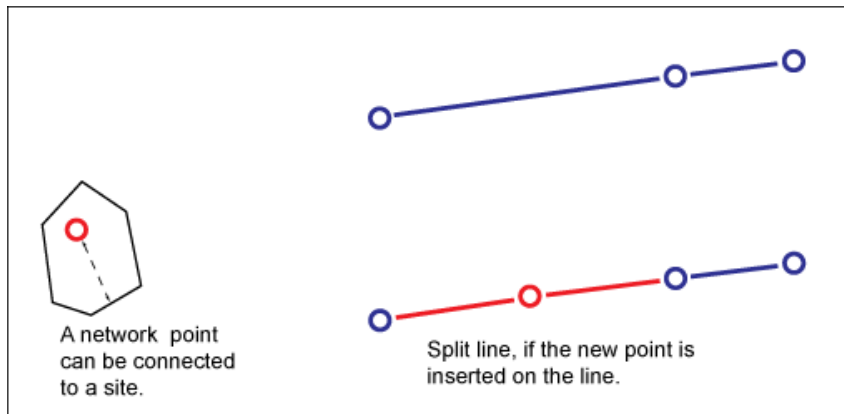

The Network Point Creation workflow splits existing lines to keep the topology correct.

To create a network point

- 1 In the Topobase Task Pane, click the Workflow explorer icon. 
- 2 Right-click the Network Point Creation workflow. Click Execute.
- 3 In the feature class list, select the type of network point feature you want to create.
You can also double-click a point type to start digitizing with the current options.
- 4 Specify a reference record, if any.
- 5 In the Site area, click one of the following options:
 - None – Specifies no site is associated with the point.
 - Digitize – Prompts you to create a site.
If you create a new site, specify the geometry type for the site.
 - Connect To – Prompts you to select an existing site.
- 6 Click OK.
- 7 Follow the prompts to create the new point.
- 8 Press ESC to finish the workflow.
When you are finished creating geometry, the feature class form is displayed so you can add attribute data.

If you place the network point on a line feature such as a pipe, you are prompted to create a soft split or a hard split. For more information, see [Split Lines](#) (page 29).

Network Pipe Creation

Use the Network Pipe Creation workflow to create network pipes with or without casing or anode protection.

Use this workflow to create network pipes with or without fitting points at start and end points.

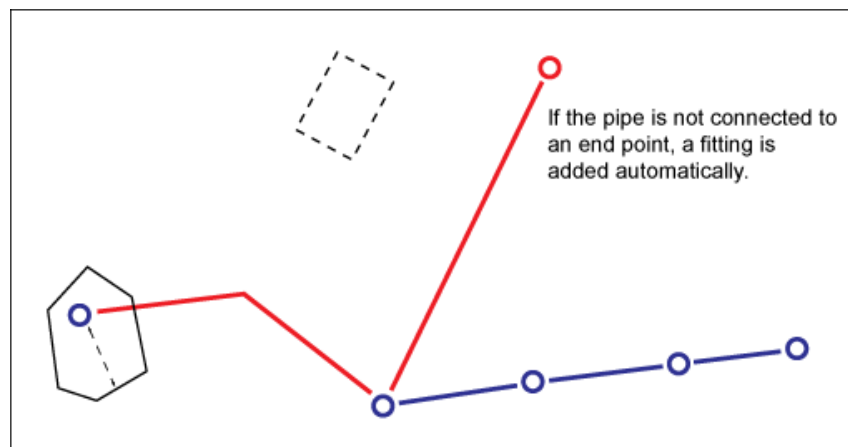

To create a network pipe

- 1 In the Topobase Task Pane, click the Workflow explorer icon. 
- 2 Right-click the Network Point Creation workflow.
- 3 Click Execute.
- 4 Specify a reference record, if any.
- 5 Under Choose Protections, specify whether to create casing, anode, or both when creating the pipes.
You are prompted to create the protection features. Casings are polygons, and anodes are points.
- 6 Under Create Terrain Points, specify whether to create terrain points.

- 7 Click OK.
- 8 Follow the prompts.
- 9 Press ESC to finish the workflow.
When you are finished creating geometry, the feature class form is displayed so you can add attribute data.

Feature Rules

Feature rules ensure consistency on the Pipe attribute feature class, Pipe and on its related Line geometry feature class.

- If a vertex of the new pipe lies exactly on an existing network point feature, the pipe is soft split, see [Split Lines](#) (page 29).
- If you create a pipe with a start or end that is not connected to a network point, by default a fitting is created, see [Feature Rule: Create Start and End Nodes](#) (page 38)

For more information about utility feature rules see Utility Feature Rules in the Topobase Administrator Guide.

See also:

- [Terrain Point](#) (page 49)
- [Network Pipe with Fitting Point Creation](#) (page 6)

Network Pipe with Fitting Point Creation

Use this workflow to create network pipes. If you create a pipe with a start or end that is not connected to a network point, a fitting is created.

If you do not want to create fitting points, you can use the Network Point Creation workflow, see [Network Pipe Creation](#) (page 5).

To create a network pipe with a fitting point

- 1 In the Topobase Task Pane, click the Workflow explorer icon. 
- 2 Right-click Network Pipe with Fitting Point Creation.
- 3 Click Execute.

- 4 Draw the pipe.
- 5 When done selecting points that make up the pipe, press ENTER.
- 6 Press ESC to finish the workflow.
When you are finished creating geometry, the feature class form is displayed so you can add attribute data.

House Connection Creation

Use the House Connection Creation workflow to connect the house connector to the main pipe with a generated straight pipe or a pipe you create.

You can digitize an armature on the main pipe at the position where the house connection is attached to the main pipe and add a valve and a meter on the pipe.

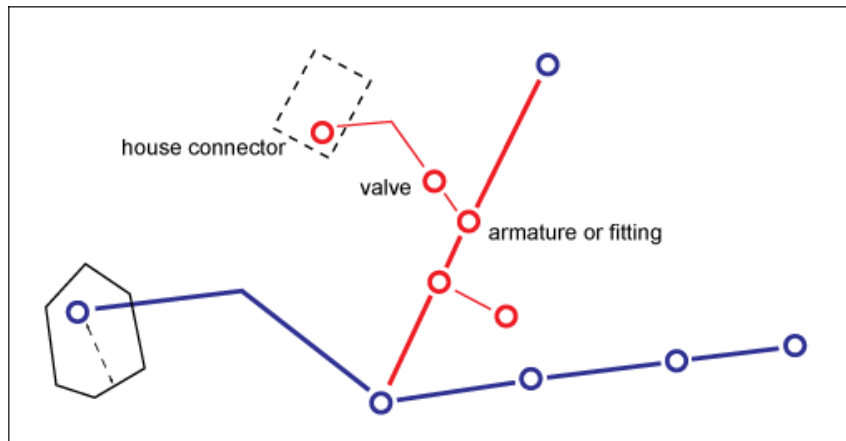

If you do not create an armature, the system creates a fitting at the location where the house connection is attached to the main pipe. This behavior is controlled by a feature rule, see [Feature Rule: Create Start and End Nodes](#) (page 38).

To create a house connection

- 1 In the Topobase Task Pane, click the Workflow explorer icon. 
- 2 Right-click House Connection Creation.

- 3 Click Execute.
- 4 Specify a reference record, if any.
- 5 Under Pipe from House Connector to Main Pipe, select Straight Pipe or Digitize Pipe.
If you choose Straight Pipe you are prompted to select the main pipe in the drawing. The connection is created as an orthogonal projection on the main pipe.
- 6 Specify whether to add an armature, a valve or a meter on the main pipe.
If you choose Armature and Straight Pipe the armature is created automatically.
- 7 Click OK.
- 8 Follow the prompts.
- 9 Press ESC to finish the workflow.
When you are finished creating geometry, the feature class form is displayed so you can add attribute data.

See also:

- [House Connector](#) (page 57)

Site or Facility Creation

Use the Site or Facility Creation workflow to create a site that can be connected to a network point or to create a facility structure with geometry.

To create a site or facility

- 1 In the Topobase Task Pane, click the Workflow explorer icon. 
- 2 Right-click Site or Facility Creation.
- 3 Click Execute.
- 4 In the Workflows pane, click Site or Facility (With Structure).
- 5 Specify a reference record, if any.
- 6 Click a geometry type for the site or facility, either point, line, or polygon.

- 7 Click OK.
- 8 Follow the prompts.
- 9 Press ESC to finish the workflow.
When you are finished creating geometry, the feature class form is displayed so you can add attribute data.

See also:

- [Site](#) (page 67)
- [Facility](#) (page 46)
- [Facility Creation](#) (page 9)

Facility Creation

Use the Facility Creation workflow to either create and name a new structure or add facilities to an existing structure. Facilities are not related to network points or lines.

To create a facility

- 1 In the Topobase Task Pane, click the Workflow explorer icon. 
- 2 Right-click Facility Creation.
- 3 Click Execute.
- 4 Under Structure Of The Facility, select the structure to add facilities to or enter a name for a new structure.
- 5 Select the type of geometry you want to create.
- 6 Click OK and follow the prompts.
- 7 Press ESC to finish the workflow.

When you are finished creating geometry, the feature class form is displayed so you can add attribute data.

The facility includes a new structure (if selected), a new facility attribute feature, and a facility geometry feature of the selected geometry type.

- 8 In the Facility feature class form, define the facility attributes for the created features.
The facility geometry feature class is not displayed, because it does not store any special attributes.
- 9 Double-click the FID Structure attribute to open the Structure feature class form.
This is the structure associated with the facility.

Add Geometry and Equipment

With the initial Facility Creation workflow you can create a facility with one geometry feature. You can add more geometries and equipment features.

To add geometry and equipment

- 1 In the Facility feature class form, select the facility.
- 2 Click Equipment to show the Equipment feature class form. If no equipment has been created so far, the filter is empty.
- 3 On the form toolbar, click the New Record icon. Note that the FID of the facility has been inserted.
- 4 Adjust the attributes and click OK.
Repeat these steps to add more geometry features to the facility.
- 5 Click Facility Line to open the related feature class form. The filter shows all lines that are related to the current facility.
- 6 On the form toolbar, click Digitize New Feature. Follow the prompts.

See also:

- [Facility](#) (page 46)

Damage Creation

Use the Damage Creation workflow to place a damage point feature on a pipe. Optionally, you can create an armature such as a strap at the damage location. If you create an armature, the pipe is soft split.

Damage points can only be placed on a pipe.

To create a damage point feature

- 1 In the Topobase Task Pane, click the Workflow explorer icon. 
- 2 Right-click Damage Creation.
- 3 Click Execute.
- 4 Specify whether to add an armature at the location of the damage.
- 5 Click OK.
- 6 Follow the prompts.
- 7 Press ESC to finish the workflow.

When you are finished creating geometry, the feature class form is displayed so you can add attribute data.

See also:

- [Damage Point](#) (page 52)

Pressure Zone Creation

Use the Pressure Zone Creation workflow to create pressure zones that subdivide the gas network into sections of similar pressure.

To create a pressure zone

- 1 In the Topobase Task Pane, click the Workflow explorer icon. 
- 2 Right-click Pressure Zone Creation.
- 3 Click Execute.
- 4 Follow the prompts to create one or more pressure zones.
- 5 Press ESC to finish the workflow.

When you are finished creating geometry, the feature class form is displayed so you can add attribute data.

NOTE With the SetPressureZone feature rule you can control the assignment of pressure zones to network objects, see [Feature Rule: Set Pressure Zone](#) (page 35).

See also:

- [Pressure Zone](#) (page 41)

Protection Creation

Use the Protection Creation workflow to add casings and/or anodes to a pipe.

To create a protection casing or anode



- 1 In the Topobase Task Pane, click the Workflow explorer icon.
- 2 Right-click Protection Creation.
- 3 Click Execute.
- 4 Select a pipe.
- 5 Under Choose Protections, click casings, anodes, or both.
- 6 Click OK to start digitizing one or more casings (closed polylines).
- 7 Press ESC to finish digitizing casings.
- 8 If selected, you are now prompted to create anodes. Create as many anodes as needed.
- 9 Press ESC to finish the workflow.
When you are finished creating geometry, the feature class form is displayed so you can add attribute data.

See also:

- [Protection](#) (page 65)

Administrative Information Creation

Use the Administrative Information Creation workflow to acquire administrative information, such as contacts, locations, supply zones, pressure zones, meter zones or manufacturers.

To create administrative information

- 1 In the Topobase Task Pane, click the Workflow explorer icon.
- 2 Right-click Administrative Information Creation.
- 3 Click Execute.
- 4 Specify which kind of information you want to acquire.
- 5 Click OK to start digitizing or entering the data.



See also:

- [Contact](#) (page 39)
- [Location](#) (page 40)
- [Manufacturer](#) (page 40)
- [Meter Area](#) (page 40)
- [Pressure Zone](#) (page 41)
- [Supply Zone](#) (page 42)

Analysis Workflows

Analysis workflows and rules allow designers to trace a gas network from one or more designated start features to an optional stop feature. Network tracing begins from the start location and stops when all stop features have been reached. You can also set attribute-dependent stop conditions, locate point objects on a pipe, locate point objects that are not connected to the network, or pinpoint error in a network topology.

Find Connected

Trace a gas network from a start feature to one or more optional stop features. The network is traced from the start feature to the stop features, if stop features are specified

TIP Network tracing is much more efficient when start and stop features are selected. Tracing a network without selecting a stop feature can take a very long time.

To find connected pipes

- 1 In the Topobase Task Pane, click the Workflow explorer icon. 
- 2 Right-click Find Connected.
- 3 Click Execute.
- 4 In the Workflow pane, under Choose A Start Feature, do the following:
 - Click Choose.
 - Click one or more features at the start of the network trace.
 - Press ENTER to complete the selection.
- 5 If you do not want to trace the whole network, do the following:
 - Under Optionally Choose Stop Features, click Choose.
 - Click one or more stop features.
 - Press Enter to complete selection.
- 6 Under Options, select Show Closing Elements to list all connected features including the stop features. If this check box is cleared, stop features are not included.

Start features are always included in the list of connected features.
- 7 To specify the trace direction, click Forward, Backward, or Both.
- 8 Click OK to start network tracing.

When network tracing has finished, all connected features are displayed in the feature explorer in the Workflows pane. Use the tools at the top of the Workflows pane to open the feature class form, highlight selected features, and zoom to selected features.

See also:

- Feature Explorer in the Topobase Client User Guide

Find Connected with Stop Conditions

The Find Connected With Stop Condition workflow provides the same functionality as the Find Connected workflow. In addition, you can define stop features based on their attributes.

All advanced stop conditions that have been defined in the data model administrator are also available here.

For more information about stop conditions using SQL statements, see Network Tracer in the Topobase Administrator Guide.

To trace connected pipes using a stop condition

- 1 In the Topobase Task Pane, click the Workflow explorer icon. 
- 2 Right-click Find Connected With Stop Conditions.
- 3 Click Execute.
- 4 In the Workflow group, under Choose a Start Feature, do the following:
 - Click Choose.
 - Click one or more features at the start of the network trace.
 - Press ENTER to complete selection.
- 5 If you do not want to trace the whole network, do the following:
 - Under Optionally Choose Stop Features, click Choose.
 - Click one or more stop features.
 - Press ENTER to complete selection.
- 6 Under Options, select Show Closing Elements to list all connected features including the stop features. If this check box is cleared, stop features are not included.
Start features are always included in the list of connected features.
- 7 To specify the trace direction, click Forward, Backward, or Both.
- 8 Under Stop Conditions, click Add.
- 9 In the Stop Condition Editor dialog box, do one of the following:
 - Select an existing stop condition.

- Click New and define a new stop condition.
To learn about creating a new stop condition, see [Create a Stop Condition](#) (page 16).
- 10 Click OK to close the Stop Condition Editor dialog box.
- 11 Click OK to start network tracing.
When network tracing has finished all connected features are displayed in the feature explorer in the Workflow pane. Use the tools at the top of the Workflow pane to open the feature class form, highlight selected features, and zoom to selected features.

In the Stop Condition Editor dialog box, the list displays only the stop conditions that are not assigned to any tracing template.

See also:

- Feature Explorer in the Topobase Client User Guide

Create a Stop Condition

Use the Stop Condition Editor in the Workflows pane to define stop conditions.

To create a stop condition

- 1 In the Topobase Task Pane, click the Workflow explorer icon. 
- 2 Right-click Find Connected With Stop Conditions.
- 3 Click Execute.
- 4 In the Stop Condition Editor section of the Workflows pane, click Add.
- 5 In the Create Stop Condition dialog box, click New and enter a name for the used stop condition.

NOTE If you do not enter a name, the stop condition is used for the current process but is not stored for later use.

- 6 Select a feature class.
- 7 Select an attribute in that feature class.

- 8 Enter a condition value for the attribute, such as =100. Note that there is no blank space between the value and the operator.
If the network trace finds a feature of the selected feature class with the specified attribute, the network trace stops at that feature.
- 9 Click OK to save the stop condition.

To edit a stop condition in the Stop Condition Editor

Note that the Stop Condition Editor list box displays only the stop conditions that are not assigned to any tracing template.

- You can only edit the stop conditions that you have created while executing a workflow.
- You cannot edit stop conditions that other users have created while executing a workflow.
- You cannot edit stop conditions that have been created using Topobase Administrator, or that have been created by the system.

Find Non Split Point on Pipe

Use Find Non Split Point On Pipe to find all points on a pipe that are not split.

Finding non split points on a pipe

- 1 In the Topobase Task Pane, click the Workflow explorer icon. 
- 2 Right-click Find Non Split Point On Pipe.
- 3 Click Execute.
- 4 Select the point feature classes to locate.
Select All to search for non split points of any feature class.
- 5 To perform the search on a specific set of features, click Choose and click the point features.
- 6 Click OK.

When the search has finished, all non split points are displayed in the feature explorer in the Workflow pane. Use the tools at the top of the Workflow pane

to open the feature class form, highlight selected features, to zoom to selected features, and to soft or hard split the pipes.

See also:

- [Feature Explorer in the Topobase Client User Guide](#)

Cable Acquisition Workflows

Use Cable Acquisition workflows to create control cables or control points that contain information about wires, cables, and electronic system controls that are deployed throughout the gas utility network. For more information, see [Control Cable](#) (page 45).

Control Cable Creation

Use the Control Cable Creation workflow to create a cable used to transmit electricity or information to system controls.

To create a control cable

- 1 In the Topobase Task Pane, click the Workflow explorer icon. 
- 2 Right-click Control Cable Creation.
- 3 Click Execute.
- 4 Follow the prompts to create one or more control cables.
- 5 When done selecting points that make up the control cables, press ENTER.
- 6 Press ESC to finish the workflow.
When you are finished creating geometry, the feature class form is displayed so you can add attribute data.

If you create a control cable with a start or end that is not connected to a network point, a cable point is created. This is controlled by a feature rule; see [Feature Rule: Create Start and End Nodes](#) (page 38).

Control Point Creation

Use the Control Point Creation workflow to create control cable points. Optionally, you can choose to connect the control cable points to a site, or you can digitize control cabinets.



- 1 In the Topobase Task Pane, click the Workflow explorer icon.
- 2 Right-click Control Point Creation.
- 3 Click Execute.
- 4 Specify a reference record, if any.
- 5 Specify whether to connect the points to a site.
- 6 Specify whether to create control cabinets.
- 7 Click OK.
- 8 Follow the prompts to create one or more control points.
- 9 Press ESC to finish the workflow.

When you are finished creating geometry, the feature class form is displayed so you can add attribute data.

See also:

- [Site](#) (page 67)

Report Workflows

Report workflows are used to generate predefined or user-defined reports. Designers can quickly and easily generate reports from a list of predefined report templates. These reports include:

Predefined Report	Description
Data Model Description	Shows a complete list of all feature classes and features in the gas database. It also shows the number of features for each feature class and how they are linked to other tables (according to the meta-table TB_RELATIONS).

Predefined Report	Description
Gas Network Statistics	Displays statistical information about point and pipe information, lists other features, and provides a count.
COGO reports	Only if the COGO extension is available. For example, ARC Intersection, or Center. See Construction Reports.

The report templates have been created with the Topobase Report Designer. For more information, refer to Report Designer Introduction in the Topobase Administrator Guide.

Report Generation

Use the Report Generation workflow to print reports. The report templates are created by your Topobase Administrator using the Topobase Report Designer.

To generate reports

- 1 In the Topobase Task Pane, click the Workflow explorer icon. 
- 2 Right-click Report Generation.
- 3 Click Execute.
- 4 In the Workflows group, select a report name and click OK.
The report is displayed in a secondary window. You can print the report or change its format to HTML, ASCII, or PDF.

Managing Gas Network Topologies

Autodesk Topobase uses topologies to model objects and phenomena of the real world. Typically, a GIS user needs information about relationships between objects with topological characteristics. Models of land and other flat surfaces is a perfect application for area topology. Logical topology is appropriate wherever real world objects are connected to each other in networks.







Topobase Gas is based on the [utility model](#) (page 78) and network topology which is used for network tracing.

For more information about defining and managing topologies, refer to Topology Introduction in the Topobase Administrator Guide.

Check Topologies

Use the Topology Checker to locate errors in a network topology. For more information about the Topology Checker, refer to Topology Checker in the Topobase Administrator Guide.

To check a topology for errors

- 1 Click the Document explorer icon. 
- 2 Expand the Topologies listing and right-click the topology. Click Topology Checker.
Topology errors are displayed in the Logical Topology Checker Desktop dialog box.
- 3 Navigate the tree view to select specific features.
- 4 Use the Topology Checker tools to perform the following operations on selected features:
 -  Refresh the topology check after you have addressed problems.
 -  Open the feature class form.
 -   Highlight a feature or clear all highlighted features.
 -  Zoom to a selected feature in the map.
 -  Delete a selected feature.

See also:

- [Gas Topologies](#) (page 71)

Explore Stop Conditions

Network topologies contain predefined stop conditions. You can view them with the Topobase Administrator.

To explore stop conditions

- 1 Start Topobase Administrator and open the Gas workspace.
- 2 Click Document menu ► Data Model to select the document.
- 3 In the data model explorer, expand Topologies.
- 4 Expand a topology and expand the Conditions folder.
- 5 Right-click the stop condition you want to view and click Properties. The Tracing Condition dialog box is displayed.
- 6 View or edit the setting for the stop condition or click Cancel to exit.

See also:

- [Create a Stop Condition](#) (page 16)

For more information about defining conditions, see Network Tracer in the Topobase Administrator Guide.

Use Gas Feature Functions

Each point and line feature class form provides functions for further processing of the selected records. These functions are available in the Function menu and the Network Tracer menu of the feature classes to which they apply.

To view available functions

- 1 Click the Document explorer icon. 
- 2 Under Topics, expand a feature. For example, Point.

- 3 Right-click a feature class. For example, Armature.
- 4 Click Show Form.
- 5 On the Armature feature class form, do one of the following:
 - Click Function menu ► *function_name*.
Where *function_name* is the name of any function available to the selected feature.
 - Click Network Tracer menu ► *menufunction_name*.

If you start a function from the feature class form, consider the current filter. You can apply the function to all features in the filter or to the current feature.

See also:

- [Point Feature Class Form](#) (page 54)
- [Pipe Feature Class Form](#) (page 49)

Maintenance Record Creation

You can create maintenance records for several feature classes. Use this function to add maintenance information to a feature. Maintenance information is stored in the Maintenance feature class (GA_MAINTENANCE).

To create a maintenance record

- 1 Select a feature in your map. For example, an Armature.
- 2 Right-click the Armature feature and select Attributes.
The Armature feature class form is displayed.
- 3 On the Armature feature class form, do one of the following:
- 4 Click Function ► Create Maintenance.
The Maintenance feature class form is displayed with a new record.
- 5 Click the Details tab and enter a maintenance date and maintenance period.
The Next Maintenance Date is automatically calculated based on the entries you make for the maintenance date and maintenance period.

- 6 Do one of the following:
 - Click Update to accept the entries you made and keep the maintenance form open for further changes. If no further changes are necessary, close the window.
 - Click Update & Close to accept the entries you made and close the maintenance form.

See also:

- [Maintenance](#) (page 48)

Marker Creation

You can create markers that are assigned to the current feature.

To create a marker

- 1 Select a feature in your map. For example, a Pipe.
- 2 Right-click the Pipe feature and select Attributes.
The Pipe feature class form is displayed.
- 3 Select the features to which you want assign a marker.
- 4 Click Function menu ► Create Marker.
- 5 Follow the prompts to create the marker.
The Marker feature class form is displayed with a new record.

See also:

- [Marker](#) (page 48)

Show Input and Output Pipes

For network points, such as armatures or fittings, you can show connected input and output pipes.

To show input or output pipes

- 1 Select a feature in your map. For example, an Armature.

- 2 Right-click the Armature feature and select Attributes.
The Armature feature class form is displayed.
- 3 In the Armature feature class form, do one of the following:
 - Click Function menu ► Show Input Pipes.
 - Click Function menu ► Show Output Pipes.

The related feature class forms are displayed and the input and output pipes are highlighted in the drawing.

See also:

- [Pipe](#) (page 50)

Show Connected Pipes

For network points, such as armatures or fittings, you can show connected input pipes.

To show connected pipes

- 1 Select a feature in your map. For example, an Armature.
- 2 Right-click the Armature feature and select Attributes.
The Armature feature class form is displayed.
- 3 Click Function menu ► Show Connected Pipes.
The related feature class forms are opened and the pipes are highlighted in the drawing.

See also:

- [Pipe](#) (page 50)

Connect a Point to a Site

Use this function if you have created sites separately from the gas network and want to associate them.

To connect a point to a site

- 1 Select a Site feature in your map.
- 2 Right-click the Site feature and select Attributes.
The Site feature class form is displayed.
- 3 Click Function menu ► Connect Point to Site.
All points that lie inside the site detail polygon are connected.

See also:

- [Site](#) (page 67)

Remove Connections from a Site

You can remove all connections that are related to a site.

To remove connections from a site

- 1 Select a Site feature in your map.
- 2 Right-click the Site feature and select Attributes.
The Site feature class form is displayed.
- 3 Click Function menu ► Remove Site.
Confirm the removal of the site and the record is removed.

See also:

- [Site](#) (page 67)

Network Tracer

Use the Network Tracer functions to specify start and stop features for network analysis.

To specify start and end features for network tracing

- 1 Select a feature in your map. For example, a Pipe.
- 2 Right-click the Pipe feature and select Attributes.

The Pipe feature class form is displayed.

- 3 Open the Network Tracer menu do one of the following:
 - Click Set as Start Feature.
 - Click Set as End Feature.

The Network Tracer dialog box is displayed.

- 4 In the Network Tracer dialog box, open the Tracing Template list and select a template.
- 5 Follow the on-screen instructions in the Features section. Depending on the tracing template, there are various workflows. When you are finished, click Trace.

The resulting features are highlighted in the map and listed in the Tracing Result dialog box.

The Tracing Result dialog box displays the features in an explorer tree, from which you can process the features. Expand the items, select a feature and use the buttons on the toolbar.

To learn more about attributive network topologies, see [Creating Topologies](#) in the Topobase Administrator Guide.

See also:

- [Analysis Workflows](#) (page 13)

Connect Features to a Zone

Use this function to connect features that lie within a pressure zone or a supply zone. You can use a feature rule to connect the features to the pressure zone or supply zone.

To connect features to a zone

- 1 Click the Document explorer icon. 
- 2 Expand the Administration topic and do one of the following:
 - Right-click Pressure Zone.
 - Right-click Supply Zone.

- 3 Click Show Form.
- 4 Click Function menu ► Associate Related Features to the Zone.
Features are connected to the zone.

See also:

- [Feature Rule: Set Pressure Zone](#) (page 35)
- [Feature Rule: Set Supply Zone](#) (page 37)

Use a Reference Record

Reference records are used to create data more quickly. Define one or more reference records for each feature class. These can be used in a workflow. You can:

- Use no reference record.
- Use the last used reference record.
- Select an available reference record.

NOTE To explore available reference records, open the related feature class form in Edit mode.

To create a reference record

- 1 Click the Document explorer icon. 
- 2 Expand the Point topic.
- 3 Right-click the feature class for the reference record you want to create. For example, House Connector.
- 4 Right-click and click Show Form.
- 5 In the form, right-click in the background and click Reference Record ► Add.
The New Reference Record dialog box is displayed.
- 6 In the Name field, enter a name, such as Digitized House Connector, and click OK.

- 7 In Reference Record mode, enter the reference values to be used, such as Accuracy = Digitized.
- 8 Click Save.

For more information about reference records, see Reference Records in the Topobase Client User Guide.

Split Lines

If you place a point feature on a line or polyline feature, the line or polyline is split to preserve a correct network topology.

To digitize a point and split a line

- 1 Click the Document explorer icon. 
- 2 Expand the topic for the line you want to split. For example, Pipe.
- 3 Right-click the Pipe feature class and do one of the following:
 - Click Soft Split (Only Geometry)
 - Click Hard Split (Also Attributes)
- 4 In the drawing, select the line representing the pipe.
- 5 In the Select dialog box, select the point feature class you want to digitize. For example, select Meter.
- 6 Digitize the point.

The new point does not need to lie exactly on the selected line. If the point lies next to the line, the line is split and the new lines move to the point. However, if the point lies on a line that is not the selected one, no splitting is performed.

NOTE Use Object Snap and Object Snap Tracking to ensure that the point is placed on the line. For more information, refer to AutoCAD Help.

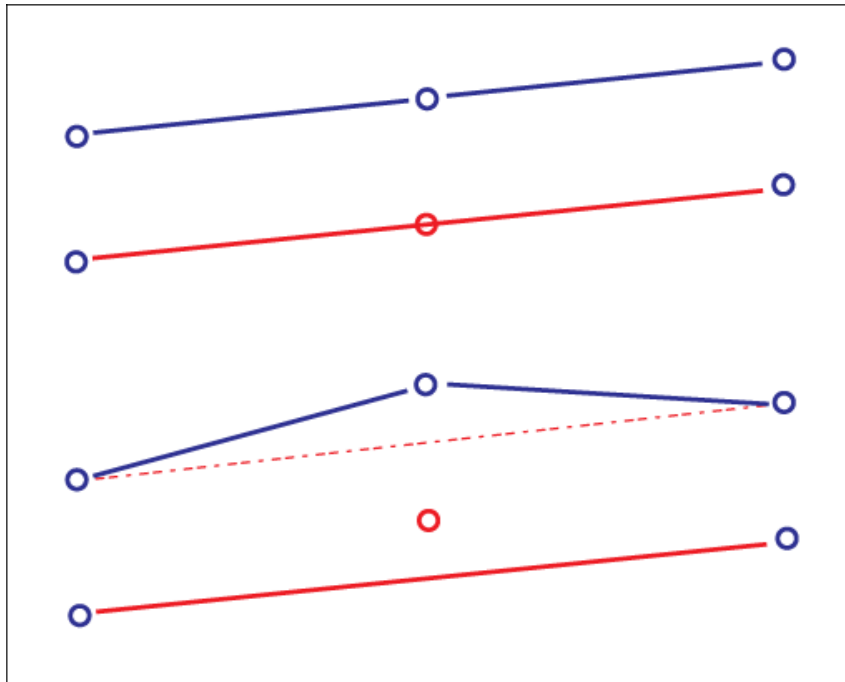

Splitting lines: When you digitize a point on a utility line or next to a utility line, the new lines move to the point.

When a pipe is digitized, normally only the start and the endpoint coordinates are known, and connected using a straight line. Then, when a new point is measured, such as a house connector, this point normally does not lie exactly on the pipe, and the pipe must be adjusted to this new point.

Soft Split and Hard Split

Because geometry and attributes are stored separately, one geometry feature class such as a point, can represent various attribute feature classes such as armature and fitting. For line features, there are two different line splitting methods: soft split and hard split.

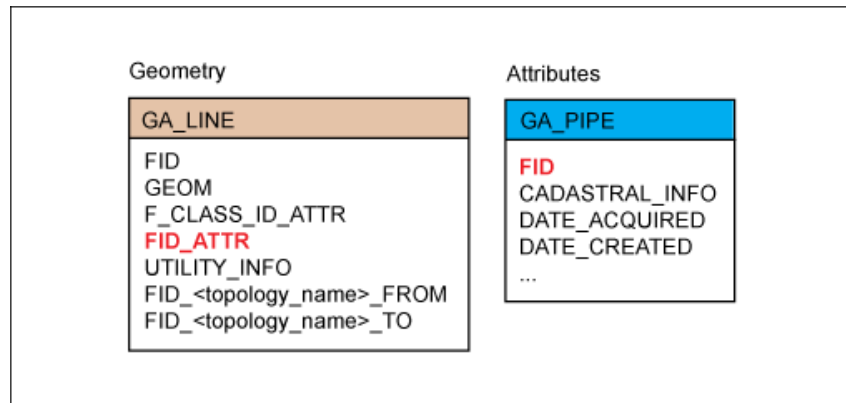

Gas data model: Relation between pipe and line feature class

In a workflow you can specify whether the line is soft split or hard split. This determine how the system handles the attribute data of the two resulting features.

Split Type	Description
Soft Split	<p>With soft split, the line is split into two separate features. Each has its own geometry (GA_LINE), but they both use the same attribute data (GA_PIPE).</p> <p>Use soft split for point features of minor importance and when the attributes of the pipe do not change, such as armatures.</p>
Hard Split	<p>With hard split, the line is split into two separate features. Each has its own geometry (GA_LINE) and each has its own attribute data (GA_PIPE).</p> <p>Use hard split for point features of major importance, such as a pump or a valve.</p> <p>Use hard split if the attributes of the pipe change, such as diameter, material, or model.</p>

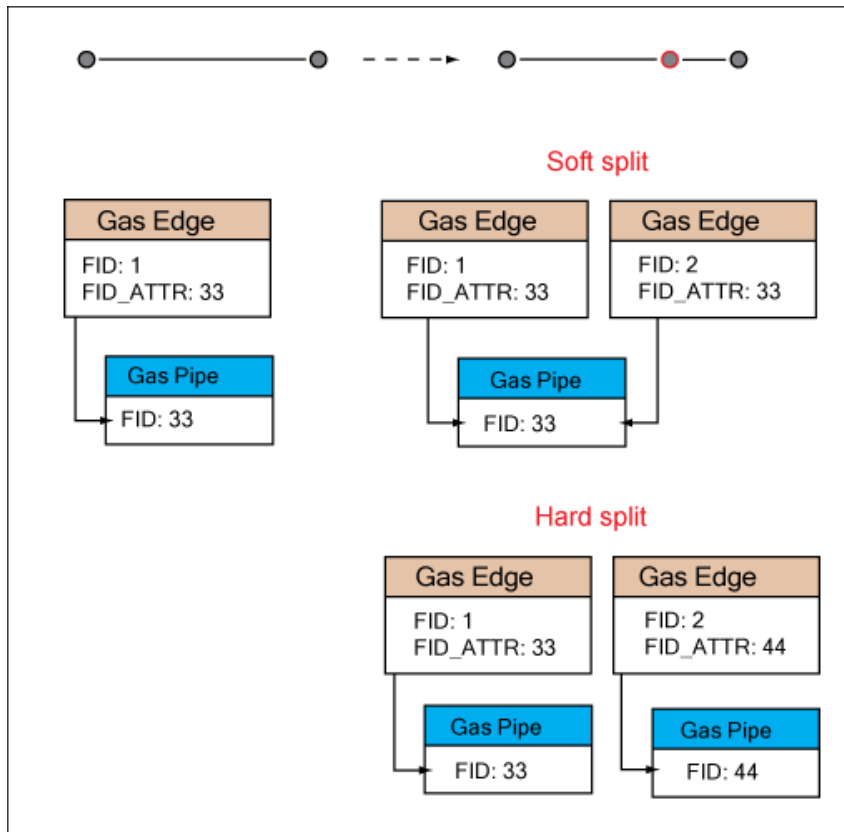

Gas data model: Soft and hard split

See also:

- [Gas Topologies](#) (page 71)

Extract Points from Lines

If you delete a point, you must update the network topology to keep the network consistent. For example, if you delete a network point, you must merge the two connected lines. If more than two lines are connected at the point, you are not allowed to delete the point.

To extract a point



- 1 Click the Document explorer icon.
- 2 Right-click the point feature class and click Extract From Line.
- 3 When prompted, click the point you want to delete.
The point is deleted from the database and the connected lines are merged.

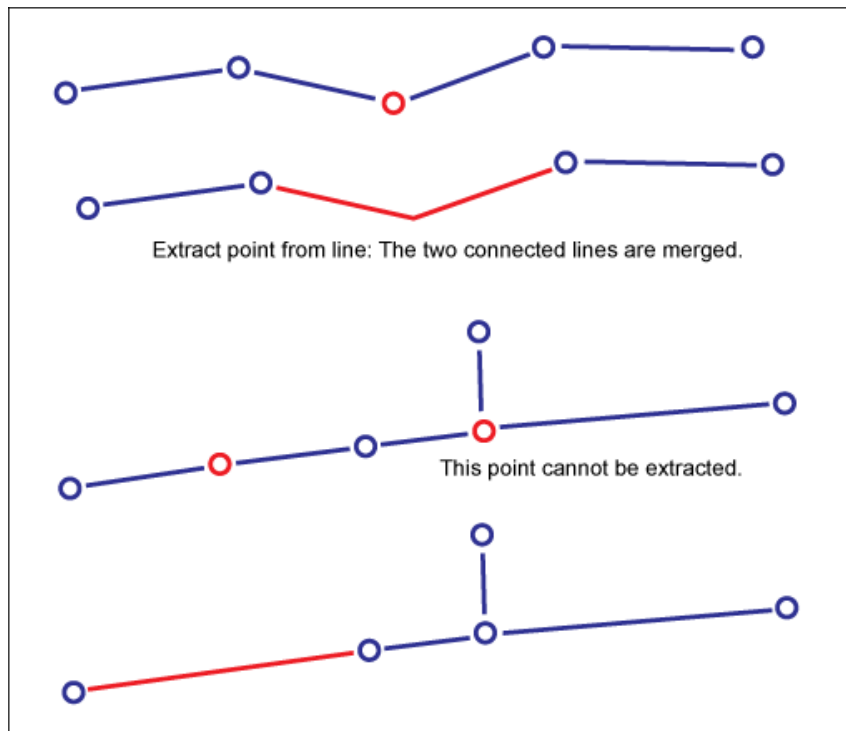

Network topology: Extracting points from a network line

See also:

- [Gas Topologies](#) (page 71)

Organization of Gas Functions and Features

When you run Data Acquisition workflows in the Gas application, the following feature rules improve the efficiency of adding features and keep data consistent.

- **Soft split** — If a network line has a network point on a vertex, the line is split.
- **Point orientation** — If you place a point on a pipe, the symbol is oriented according to the direction of the pipe.
- **Move** — If a pipe is moved, the connected pipe and points also move.
- **Identical points** — Ensure that no gas network points or cable control points are created in the same location. See the Topobase Feature Rule reference, section [GA_RejectDuplicatePoints_BIU](#).
- **Pressure zone** — Enable or disable the pressure zone rule for a feature if it is located within a zone. See [Feature Rule: Set Pressure Zone](#) (page 35).
- **Supply zone** — Enable or disable the supply zone rule for a feature if it is located within a zone. See [Feature Rule: Set Supply Zone](#) (page 37).
- **Compute maintenance** — Compute maintenance dates based on current maintenance dates and maintenance periods. See the Topobase Feature Rule reference, section [GA_ComputeNextMaintDate_BIU](#).

For more information about feature rules, see Feature Rules Introduction in the Topobase Administrator Guide.

See also:

- [Split Lines](#) (page 29)
- [Pressure Zone](#) (page 41)
- [Supply Zone](#) (page 42)

Explore Gas Feature Rules

Many feature classes in the gas data model are comprised of feature rules. Use the data model administrator to view, enable, or disable feature rules.

To explore gas feature rules

- 1 Start Topobase Administrator and open the Gas workspace.
- 2 Click Document menu ► Data Model.
- 3 Expand a topic in the data model explorer.
- 4 Right-click a feature class and click Edit Feature Rules.
The Feature Rules Properties dialog box is displayed.
- 5 In the Feature Rules Properties dialog box, click the Client Side (.NET) tab.
- 6 In the Applied Rule Bases list, enable or disable the rules you want adjusted.
- 7 Click Save & Close.

See also:

- [Organization of Gas Functions and Features](#) (page 34)

For more information about feature rules, see Feature Rules Introduction in the Topobase Administrator Guide.

Feature Rule: Set Pressure Zone

When you digitize gas network features, a feature rule sets the pressure zone for a feature if it is located within a zone. If the feature is located in overlapping zones, you are prompted to select a zone. If you select Yes, you can select a zone. If you select No, the pressure zone value is cleared.

NOTE If you digitize a pressure zone while the gas network features already exist, the pipes are not updated and do not belong to the pressure zone.

You can use a feature function to update the relations. See also [Connect Features to a Zone](#) (page 27)

To activate the Set Pressure Zone feature rule (Line feature class)

- 1 Start Topobase Administrator and open the Gas workspace.
- 2 Click Document menu ► Data Model.
- 3 Expand the Utility topic and select the Line feature class (GA_LINE).

- 4 Right-click and click Edit Feature Rules.
The Feature Rules Properties dialog box is displayed.
- 5 In the Feature Rules Properties dialog box, click the Client Side (.NET) tab.
- 6 In the Applied Rule Bases list, enable the GA_SetPressureZone_BIU and the GA_SetPressureZone_AIU rules.
- 7 Click Save & Close.

To apply the Set Pressure Zone feature rule (Point feature class)

- 1 Start Topobase Administrator and open the Gas workspace.
- 2 Click Document menu ► Data Model.
- 3 Expand the Point topic and select the feature class. For example, Fitting (GA_FITTING).
- 4 Right-click and click Edit Feature Rules.
The Feature Rules Properties dialog box is displayed.
- 5 In the Feature Rules Properties dialog box, click the Client Side (.NET) tab.
- 6 In the Applied Rule Bases list select the GA_SetPressureZone_BI rule.
- 7 Click Save & Close.

To activate the Set Pressure Zone feature rule (Pipe feature class)

- 1 Start Topobase Administrator and open the Gas workspace.
- 2 Click Document menu ► Data Model.
- 3 Expand the Pipe topic and select the Pipe feature class (GA_PIPE).
- 4 Right-click and click Edit Feature Rules.
The Feature Rules Properties dialog box is displayed.
- 5 In the Feature Rules Properties dialog box, click the Client Side (.NET) tab.
- 6 In the Applied Rule Bases list, select the GA_SetPressureZone_BI rule.
- 7 Click Save & Close.

See also:

- [Pressure Zone](#) (page 41)
- GA_SetPressureZone_BI
- GA_SetPressureZone_BIU rule group

Feature Rule: Set Supply Zone

When you digitize gas network features, a feature rule sets the supply zone for a line feature if it is located within a zone. If the feature is located in overlapping zones, you are prompted to select a zone. If you select Yes, you can select a zone. If you choose No, the pressure zone value is cleared.

NOTE If you digitize a supply zone while the gas network features already exist, the pipes are not updated and do not belong to the supply zone.

You can use a feature function to update the relations. See also [Connect Features to a Zone](#) (page 27)

To activate the Set Supply Zone feature rule (Line feature class)

- 1 Start Topobase Administrator and open the Gas workspace.
- 2 Click Document menu ► Data Model.
- 3 Expand the Utility topic and select the Line feature class (GA_LINE).
- 4 Right-click and click Edit Feature Rules.
The Feature Rules Properties dialog box is displayed.
- 5 In the Feature Rules Properties dialog box, click the Client Side (.NET) tab.
- 6 In the Applied Rule Bases list, enable the GA_SetSupplyZone_BIU and the GA_SetSupplyZone_AIU rules.
- 7 Click Save & Close.

To activate the Set Supply Zone feature rule (Pipe feature class)

- 1 Start Topobase Administrator and open the Gas workspace.
- 2 Click Document menu ► Data Model.

- 3 Expand the Pipe topic and select the Pipe feature class (GA_PIPE).
- 4 Right-click and click Edit Feature Rules.
The Feature Rules Properties dialog box is displayed.
- 5 In the Feature Rules Properties dialog box, click the Client Side (.NET) tab.
- 6 In the Applied Rule Bases list, select the GA_SetSupplyZone_BI rule.
- 7 Click Save & Close.

See also:

- [Supply Zone](#) (page 42)

Feature Rule: Create Start and End Nodes

The CreateStartEndNode feature rule controls the automatic creation of network points.

If you create a pipe with a start or end that is not connected to a network point, a fitting is created. Sometimes the gas network does not continue beyond a certain point. If you need to create non-ending pipes, you can disable this feature rule. Also, you can configure the feature rule, so that a network point of any type is created.

If you create a control cable with a start or end that is not connected to a network point, a cable point is created.

To enable or disable the CreateStartEndNode feature rule for pipes

- 1 Start Topobase Administrator and open the Gas workspace.
- 2 Click Document menu ► Data Model.
- 3 Expand the Utility topic and select the Line feature class (GA_LINE).
- 4 Right-click and click Edit Feature Rules.
The Feature Rules Properties dialog box is displayed.
- 5 In the Feature Rules Properties dialog box, click the Client Side (.NET) tab.
- 6 In the Applied Rule Bases list, select or deselect the CreatetStartEndNode rule and click Edit.

The Edit Rule Base dialog box is displayed.

- 7 In the Edit Rule Base dialog box, do the following:
 - Select or clear the Active option.
Optionally, you can also enable or disable the feature rule in the Feature Rules Properties dialog box.
 - In the Parameters field, specify which point feature class to create.
For example, GA_FITTING.
 - Click OK.
- 8 Click Save & Close.

See also:

- [Network Pipe Creation](#) (page 5)
- [Control Cable Creation](#) (page 18)
- CreateStartEndNode

Administration

These attribute feature classes manage contacts, customers, locations, manufacturers, and item models.

In addition, the Administration topic includes feature classes for meter areas, pressure zones, protection zones, and supply zones.

Contact

This feature class manages contact information, such as company address, contact name, and email.

Contact	Description
Topic	Administration
Table name	GA_CONTACT

You can access the contact form from most of the feature class forms using a relation.

In the contact form, you can access several gas network features using the link buttons in the Related Tables tab.

Location

This feature class groups gas utility features by geographical relation.

Location	Description
Topic	Administration
Table name	GA_LOCATION

Manufacturer

Use the Manufacturer feature class to manage the manufacturers of the gas network items.

Manufacturer	Description
Topic	Administration
Table name	GA_MANUFACTURER

Meter Area

Meter areas are used for visual grouping only.

Meter Area	Description
Topic	Administration
Table name	GA_METERAREA
Shortcut Menu	Workflow: Administrative Information Creation. For more information, see Administrative Information Creation (page 12).

Pressure Zone

Pressure zones are used to group gas utility items.

Pressure Zone	Description
Topic	Administration
Table name	GA_PRESSUREZONE
Shortcut Menu	Workflow: Administrative Information Creation. For more information, see Administrative Information Creation (page 12).

Feature Rule

Optionally, when digitizing a network feature within an existing area, the feature is related to the pressure zone. If you digitize a network feature that lies within several pressure zones, you are prompted to select the zone to which you want to connect.

This option is controlled by the feature rule SetPressureZone. You can enable or disable this feature rule in the data model administrator. See also [Feature Rule: Set Pressure Zone](#) (page 35)

To view related pipes

- 1 Select the pressure zone in the drawing.

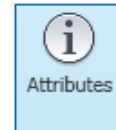

- 2 Click Home tab ► Quick Access panel ► Attributes.
- 3 In the Pressure Zone form, click the Related Tables tab.

- 4 Click the Pipes (GA_PIPE)  reference button.

The Pipes form is displayed showing all related pipes in the filter.

See also:

- [Pressure Zone Creation](#) (page 11)

Supply Zone

Supply zones are used to group gas utility items.

Supply Zone	Description
Topic	Administration
Table name	GA_SUPPLYZONE
Shortcut Menu	Workflows: Administrative Information Creation. For more information, see Administrative Information Creation (page 12).

Feature Rule

Optionally, when digitizing a pipe within an existing zone, the pipe is related to the supply zone. This is controlled by the feature rule SetSupplyZone. You can enable or disable this feature rule in the data model administrator. See also [Feature Rule: Set Supply Zone](#) (page 37).

Gas Model Feature Classes

For a large number of feature types, Topobase Gas provides model driven attributes. You use model tables (*_MODEL) to fill the model driven attributes. Model tables describe several types (models) of a particular network item. They can be grouped by manufacturer. Create models for gas network items to simplify data acquisition.

For example, in a gas utility network with five kinds of valves, you would fill the model driven attributes using a predefined record from the GA_VALVE_MODEL table. In the Valve feature class form, you use the Model Selector control to fill in the model field easily.

NOTE In the Model input field, the value Choose Model indicates that you can apply a model. It does not store the model that has been applied, because at any time you can modify the model driven attributes. The attributes are stored in the main feature class, and you use the model feature class to insert a set of attributes. You can use the model table to store reference values.

BEST PRACTICE In the feature class form, use the Model table, to search for an appropriate model. Use the model list, if you are sure which model to use. In the Form Designer, modify the model table form to hide or show model attributes, or to modify the order in the grid. Modify the main feature class form to move the Model selector to another location.

Usually the model information is created either at the beginning of the project or during data acquisition.

See also Data Model: Model Tables.

The following table is an example of a pipe model table.

Table name	GA_PIPE_MODEL
CERTIFICATE	Description of DIN/ISO/DVGW/TUEV value.
DATE_CREATION	Date when the item was created.
DIAMETER_INSIDE	Inside diameter of the pipe.
DIAMETER_NOMINAL	The manufacturer's designated size, or nominal diameter for the subject item, such as 1" gas hydrant, 2" meter, 6" pipe.
DIAMETER_OUTSIDE	Outside diameter of the pipe.
FID_MANUFACTURER	GA_MANUFACTURER Manufacturer of this item.
ID_COATING_INSIDE	GA_COATING_TBD
ID_COATING_OUTSIDE	GA_COATING_TBD
ID_MATERIAL	GA_MATERIAL_TBD
NARRATIVE	A description or other unique information concerning the item.
PRESSURE_MAX	The manufacturer's or industry standard's maximum pressure rating.
THICKNESS	Thickness of the pipe wall.

USER_FLAG	An operator-defined work area. This attribute can be used by the operator for user-defined system processes. It does not affect the subject item's data integrity and should not be used to store the subject item's data.
MODEL_NAME	Name of the model.
VALUE	Short description of the model. This value is used for the domain table representation of the model.

The following table is an example of a valve model table.

Table name	GA_VALVE_MODEL
DATE_CREATION	Date when the item were created.
DIMENSION1	Dimension 1 of the item.
DIMENSION2	Dimension2 of the item.
FID_MANUFACTURER	GA_MANUFACTURER
ID_MATERIAL	GA_MATERIAL_TBD
ID_TYPE	GA_VALVE_TYPE_TBD Particular kind, class, or group of valve, such as gate or check.
NAME_NUMBER	Model name or number.
NARRATIVE	A description or other unique information.
USER_FLAG	An operator-defined work area. This attribute can be used by the operator for user-defined system processes. It does not affect the subject item's data integrity and should not be used to store the subject item's data.

VALUE	Short description of the model. This value is used for the domain table representation of the model.
MODEL_NAME	Name of the model.

Control Cable

The control cable feature contains information about wires, cables, and electronic system controls that are deployed throughout the gas utility network. The control cable feature is where information such as sensory control and data acquisition (SCADA) on the cable point, control cabinet, and control cable is stored. It includes the following feature classes:

- Control cabinet — a cabinet for the cable where electrical nodes are located.
- Control cable — a cable used to transmit electricity or information to system controls.
- Control cable point — a cable point that represents an electrical node.

The data model for control cables is based on the utility model.

See also:

- [Gas Topologies](#) (page 71)
- [Cable Acquisition Workflows](#) (page 18)

Control Cabinet

A cabinet for the cable where electrical nodes are located.

Control Cabinet	Description
Topic	Control Cable
Table name	GA_C_Control_Cabinet

Control Cable

A cable used to transmit electricity or information to system controls.

Control Cable	Description
Topic	Control Cable
Table name	GA_C_Cable
Shortcut menu	Reverse Direction Soft Split (Only Geometry) Hard Split (Also Attributes) For more information, see Split Lines (page 29). Workflows: Control Cable Creation. For more information, see Control Cable Creation (page 18).

Control Cable Point

A cable point that represents an electrical node.

Control Cable Point	Description
Topic	Control Cable
Table name	GA_C_Cable_Point
Shortcut menu	Workflows: Control Point Creation. For more information, see Control Point Creation (page 19). Extract Points From Lines. For more information, see Extract Points from Lines (page 32).

Facility

Topobase Gas contains a simple data structure for facility management. You can use these feature classes to maintain equipment, such as chairs and tables. Facility features are not part of the network topology. They are used for orientation or illustration purposes. The predefined feature classes come with

a number of attributes. The means by which attributes are stored in the facility topic are dependant upon the project and purpose.

Facility	Description
Topic	Facility
Table name	GA_FACILITY_*
Geometry	The geometry feature classes store the geometry for the graphical representation. They do not store attributes of the facility features, except attributes to control the representation, such as linetype or symbol.
Shortcut Menu	Workflows: Facility Creation. For more information, see Facility Creation (page 9).

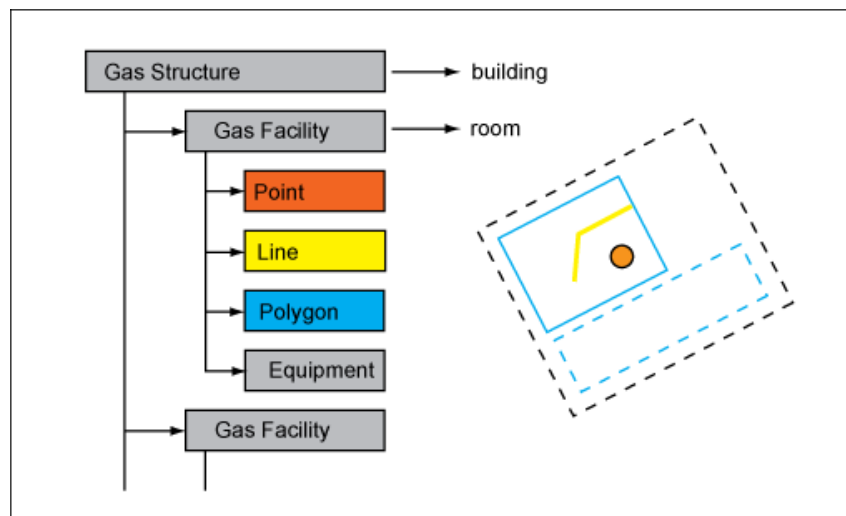

A Gas structure can be a building with rooms (facilities) containing equipment such as desks and chairs. The facility has geometry. Structure and equipment are attribute feature classes.

Miscellaneous

Maintenance

This feature class stores information about maintenance work. The feature class uses the maintenance type domain table. In the basic gas application, this domain table contains only general maintenance types. It can be modified to meet the requirements of a customized gas application.

Maintenance	Description
Topic	Miscellaneous
Table name	GA_MAINTENANCE

Use the Create Maintenance feature function to create maintenances.

See also:

- [Use Gas Feature Functions](#) (page 22)
- [Maintenance Record Creation](#) (page 23)

Marker

A marker, such as a sign or a concrete monument, is installed either directly above or immediately adjacent to underground lines, bends, or fittings to indicate the presence of gas. Markers are not part of the network topology and therefore recorded in a common point feature class.

Marker	Description
Topic	Miscellaneous
Table name	GA_MARKER

Use the Create Marker feature function to create markers.

See also:

- [Use Gas Feature Functions](#) (page 22)
- [Marker Creation](#) (page 24)

Terrain Point

This feature class stores height points to describe the terrain surface. Terrain points can be created during the Network Pipe Creation workflow. For example, they are used to represent the terrain surface in profile drawings.

Terrain Point	Description
Topic	Miscellaneous
Table name	GA_TERRAIN_POINT
Z	terrain height

See also:

- [Network Pipe Creation](#) (page 5)

Pipe

The basic gas application contains one gas line feature, pipe. Geometry is stored in the GA_LINE line string feature class. Attribute information is stored in the GA_PIPE attribute feature class.

The pipe feature class has a set of model driven attributes. Values for the model driven attributes are stored in the model table (suffix_MODEL). For more information, see Data Model: Model Tables.

Pipe Feature Class Form

Use the basic feature class form of the gas pipe to view and edit feature attributes and to view related data.

The pipe feature class form contains the following elements:

- **General tab** — Displays general feature information.
- **Details tab** — Displays detailed feature attributes and link buttons that provide links to all point features the pipe is connected to.

- **Related Tables tab** — Allows direct access to the following related tables:

Related Table	Table Name and Description
Line	GA_LINE – Contains line geometry.
Label	GA_PIPE_TBL – Contains labels for pipe features.
Marker	GA_MARKER – Contains marker information. The marker is placed above ground to indicate the position of a pipe feature.
Anode	GA_ANODE – Contains anode for protection of the pipe.
Casing	GA_CASING – Contains casing for protection of the pipe.
Maintenance	GA_MAINTENANCE – Contains information about pipe maintenance.
Damage	GA_DAMAGE – Contains recorded damage.

- **Table** — Displays the attributes in table form.

Some feature class forms provide functions for further processing of the selected records. These functions can be accessed via menus or control buttons. See also [Use Gas Feature Functions](#) (page 22).

Pipe

Pipes are the only standard line feature of a gas utility model.

Pipe	Description
Topic	Pipe
Table name	GA_PIPE
CADASTRAL_INFO	Contains the description of cadastral information.
GROUND_ELEVATION	Elevation relative to the ground.

Pipe	Description
ISOLATION	Description of the isolation type.
LOCATION	Brief description where the item is located (1m of the wall).
NAME_NUMBER	Name or number of the item.
NARRATIVE	A description or other unique information concerning the subject item.
PIPE_LENGTH	Length of the pipe.
PRESSURE_OPERATING	Operating pressure of the item.
SERIAL_NUMBER	Unique serial number of the manufacturer.
SLOP_MEASURED	Slop of the pipe measured by hand. This value is not calculated.
USER_FLAG	An operator defined work area. This attribute can be used by the operator for user-defined system processes. It does not effect the subject item's data integrity and should not be used to store the subject item's data.
Label definition	Displays the diameter, length, and material. See Define Labels (page 72).
Model driven attributes	Model driven attributes can either be filled with the information that is stored in the GA_PIPE_MODEL table, or you can enter values manually. You use the Model Selector control to select a set of attribute values. See also Gas Model Feature Classes (page 42).
Shortcut Menu	Reverse Direction Soft Split (Only Geometry) Hard Split (Also Attributes)

Pipe	Description
	<p>For more information, see Split Lines (page 29).</p> <p>Workflows: Network Pipe Creation. For more information see, Network Pipe Creation (page 5).</p> <p>Network Pipe With Fitting Point Creation. For more information, see Network Pipe with Fitting Point Creation (page 6).</p> <p>Damage Point Creation. For more information, see Damage Creation (page 10).</p> <p>Protection Creation. For more information, see Protection Creation (page 12).</p>

See also:

- [Network Pipe Creation](#) (page 5)
- [Network Pipe with Fitting Point Creation](#) (page 6)

Damage Point

Damage points indicate locations where damage has occurred. They can be related to a pipe. They are not part of the network topology.

Damage Point	Description
Topic	Pipe
Table name	GA_DAMAGE
Shortcut Menu	Workflows: Damage Creation. For more information, see Damage Creation (page 10).

Point

The utility points of the gas data model are stored in separate attribute feature classes, one for each point type. They are grouped in the Point topic.

Geometry is stored separately from attribute data. The network point geometry is stored in the Point feature class in the Utility topic. The utility points are:

- Armature
- Blow Off Valve
- Fill
- Filter
- Fitting
- House Connector
- Light
- Meter
- Odor Equipment
- Pig Launch
- Pump
- Regulator
- Reservoir
- Sample
- Shut Off Valve
- Siphon
- Source
- Tank
- Valve

Each point feature class has a corresponding label feature class (*_TBL) with one default label definition.

Most point feature classes have an associated model table (*_MODEL). Reservoir, House Connector and Source do not have model tables. Model tables can be found in the Administration topic of the data model, under Manufacturer.

See also:

- [Gas Topologies](#) (page 71)

Point Feature Class Form

Use the basic feature class forms of the Gas point features to view and edit feature attributes and to view related data.

All point feature class forms contain the following elements:

- **General tab** — Displays general feature information.
- **Details tab** — Displays detailed feature attributes and link buttons that provide links to all line features (usually pipes) the points are connected to.
- **Related Tables tab** — Allows direct access to the following related tables:

Related Table	Table Name and Description
Maintenance	Contains information about network maintenance.
Marker	Contains marker information. The marker is placed above ground to indicate the position of a network part.
Label	Contains label text.
Point	Contains point geometry.

- **Table tab** — Displays all attributes in table form.



Each point feature class form provides functions for further processing of the selected records. These functions can be accessed via menu or control buttons. See also [Use Gas Feature Functions](#) (page 22).

Connect Point Features to Sites

Each network point can be connected to a site. The easiest way to connect a network point to a site is to use the Network Point Creation workflow. For more information, see [Network Point Creation](#) (page 3).

If you have existing points without a site connection, you can assign them to a site.

To connect a point to a site

- 1 Click the Document explorer icon. 
- 2 Right-click the feature class, such as Armature, and click Show Form.
- 3 Select the armature to connect to the site.
- 4 Click the Related Tables tab.
- 5 Click the Point (GA_POINT)  reference button to show the related geometry feature.
- 6 In the Point feature class form, click the Details tab.
- 7 Under Site, select the FID of the related site.
- 8 Click Update (F5).

For more information about sites, see [Site](#) (page 67).

Armature

An armature is an assembly that connects pipes.

Armature	Description
Topic	Point
Table name	GA_ARMATURE
Shortcut Menu	Workflows: Network Point Creation. For more information, see Network Point Creation (page 3). Extract Points From Lines. For more information, see Extract Points from Lines (page 32).
Label definition	Default label definitions to display the name, the date of creation, and the type. See also Define Labels (page 72).

Blow Off Valve

A pressure release system using a vacuum-actuated valve designed to release excess pressurized gas into the atmosphere.

Blow Off Valve	Description
Topic	Point
Table name	GA_BLOW_OFF_VALVE
Shortcut Menu	Workflows: Network Point Creation. For more information, see Network Point Creation (page 3). Extract Points From Lines. For more information, see Extract Points from Lines (page 32).

Fill

A fill is a location where gas is discharged to users.

Fill	Description
Topic	Point
Table name	GA_FILL
Shortcut Menu	Workflows: Network Point Creation. For more information, see Network Point Creation (page 3). Extract Points From Lines. For more information, see Extract Points from Lines (page 32).

Filter

A filter captures contaminants that might be present in a gas line.

Filter	Description
Topic	Point

Filter	Description
Table name	GA_FILTER
Shortcut Menu	Workflows: Network Point Creation. For more information, see Network Point Creation (page 3). Extract Points From Lines. For more information, see Extract Points from Lines (page 32).

Fitting

A fitting is used to connect, cap, or plug a pipe carrying gas.

Fitting	Description
Topic	Point
Table name	GA_FITTING
Label definition	Displays the name and number.
Shortcut Menu	Workflows: Network Point Creation. For more information, see Network Point Creation (page 3). Extract Points From Lines. For more information, see Extract Points from Lines (page 32).

House Connector

A house connector is a service connection point on or inside a building. It is the last point of a gas network and represents the connection between the network and the consumer/customer.

Use the House Connector Creation workflow to create house connectors with connecting lines.

House Connector	Description
Topic	Point

House Connector	Description
Table name	GA_HOUSE_CONNECTOR
Shortcut Menu	<p>Workflows: Network Point Creation. For more information, see Network Point Creation (page 3).</p> <p>House Connection Creation. For more information, see House Connection Creation (page 7)</p> <p>Extract Points From Lines. For more information, see Extract Points from Lines (page 32).</p>

Manage Customer Information

The GA_HOUSE_CONNECTOR table has a Customer Number attribute. However, there is no table for managing customer information because customers often use external software (for example SAP) for this.

To manage customer information within Topobase, use the data model administrator to create the appropriate feature classes.

To manage customer information

- 1 Create a new Customer feature class in the Administration topic.
- 2 Add attributes as needed, such as Name, Address, Telephone, and E-mail.
- 3 Customize the feature class form using the Form Designer.
- 4 In the House Connector form, add a Basic ComboBox control for Customer Number and create the relation to the newly created table containing the customers.

For more information, see the Administration Introduction in the Topobase Administrator Guide.

Generate Customer Notifications

Topobase Gas helps you generate notification letters regarding planned work or interruptions in the gas network. For example, if a pipe has a defect and the gas must be stopped, you might do a network tracing to find all house connectors so you can notify customers.

There are several ways to generate customer notification letters.

- Use the Topobase Report Designer.
For more information about the Topobase report designer, see the Report Designer Introduction in the Topobase Administrator Guide.
- Use Topobase Client to export to Microsoft® Word.
- Export the data to any format and use external software to generate letters.
For example, export a customer list to Microsoft® Excel®.

Light

Use this feature class for the graphical representation of the location of a gas light fixture. A gas light fixture utilizes gas as its energy source and contains a flame used for illumination of an area.

Topic	Point
Table name	GA_LIGHT
Shortcut Menu	Workflows: Network Point Creation. For more information, see Network Point Creation (page 3). Extract Points From Lines. For more information, see Extract Points from Lines (page 32).

Meter

A meter is a device installed in a line for measuring the quantity and rate of gas flowing to a facility or through a section of line.

Meter	Description
Topic	Point
Table name	GA_METER
Shortcut Menu	Workflows: Network Point Creation. For more information, see Network Point Creation (page 3).

Meter	Description
	Extract Points From Lines. For more information, see Extract Points from Lines (page 32).

You can use the related feature class GA_MAINTENANCE to create events such as meter readings, installation, mounting, or calibration. For more information, see [Maintenance](#) (page 48).

Odor Equipment

This is equipment located the a control station that allows the addition of an odorant to a gas. An odorant provides a characteristic “warning” smell.

Odor Equipment	Description
Topic	Point
Table name	GA_ODOUR_EQUIPMENT
Shortcut Menu	Workflows: Network Point Creation. For more information, see Network Point Creation (page 3). Extract Points From Lines. For more information, see Extract Points from Lines (page 32).

Pig Launch

A pig launch is a point where a pigging device is inserted to clean up a pipe fitting.

Pig Launch	Description
Topic	Point
Table name	GA_PIG_LAUNCH
Shortcut Menu	Workflows: Network Point Creation. For more information, see Network Point Creation (page 3).

Pig Launch	Description
	Extract Points From Lines. For more information, see Extract Points from Lines (page 32).

Pump

A pump is a mechanical device for a gas system that draws material into itself through an entrance port and forces the material out through an exhaust port.

Pump	Description
Topic	Point
Table name	GA_PUMP
Shortcut Menu	Workflows: Network Point Creation. For more information, see Network Point Creation (page 3). Extract Points From Lines. For more information, see Extract Points from Lines (page 32).

Regulator

A pressure regulator automatically reduces the pressure on the downstream side of a valve to a preset magnitude.

Regulator	Description
Topic	Point
Table name	GA_REGULATOR
Shortcut Menu	Workflows: Network Point Creation. For more information, see Network Point Creation (page 3). Extract Points From Lines. For more information, see Extract Points from Lines (page 32).

Reservoir

A reservoir is a body of gas that supplies gas to a gas distribution system.

Reservoir	Description
Topic	Point
Table name	GA_RESERVOIR
Shortcut Menu	Workflows: Network Point Creation. For more information, see Network Point Creation (page 3). Extract Points From Lines. For more information, see Extract Points from Lines (page 32).

Sample

This feature class stores point locations where one or more gas samples are collected from a gas utility or system.

Sample	Description
Topic	Point
Table name	GA_SAMPLE
Shortcut Menu	Workflows: Network Point Creation. For more information, see Network Point Creation (page 3). Extract Points From Lines. For more information, see Extract Points from Lines (page 32).

Shut Off Valve

An inline valve that cuts or allows the flow of a gas or liquid through the pipes where it is installed.

Shut Off Valve	Description
Topic	Point
Table name	GA_SHUT_OFF_VALVE
Shortcut Menu	Workflows: Network Point Creation. For more information, see Network Point Creation (page 3). Extract Points From Lines. For more information, see Extract Points from Lines (page 32).

Siphon

A siphon is a continuous tube that allows liquid to flow from a source reservoir to a storage reservoir. By means of a difference in hydrostatic pressure, liquid flows from the end of the tube in the source reservoir through an intermediate point that is higher than the source reservoir toward the opposite end of the tube. The opposite end of the tube must be lower than the liquid surface in the source reservoir.

Siphon	Description
Topic	Point
Table name	GA_SIPHON
Shortcut Menu	Workflows: Network Point Creation. For more information, see Network Point Creation (page 3). Extract Points From Lines. For more information, see Extract Points from Lines (page 32).

Source

A source is the point from which gas is supplied for processing and distribution.

Source	Description
Topic	Point
Table name	GA_SOURCE
Shortcut Menu	Workflows: Network Point Creation. For more information, see Network Point Creation (page 3). Extract Points From Lines. For more information, see Extract Points from Lines (page 32).

Tank

A tank is an above or below grade receptacle or chamber used for holding gas on a temporary basis prior to transfer or use.

Tank	Description
Topic	Point
Table name	GA_TANK
Shortcut Menu	Workflows: Network Point Creation. For more information, see Network Point Creation (page 3). Extract Points From Lines. For more information, see Extract Points from Lines (page 32).

Valve

A valve is a fitting or device used for shutting or throttling flow through a gas line.

Valve	Description
Topic	Point
Table name	GA_VALVE
Shortcut Menu	Workflows: Network Point Creation. For more information, see Network Point Creation (page 3). Extract Points From Lines. For more information, see Extract Points from Lines (page 32).

Profile

This topic stores the profile feature classes.

Feature Class	Description
TB_PROFILE	Profile system table to store the profile origin.
TB_PROFILE_AXIS	Profile system table to store the profile axis.
GA_XXX_PRO	Profile feature classes to store the profile drawing.

To create profiles, see Profile Manager in the Topobase Client User Guide.

Protection

Use the anode, anode station (point), and casing (polygon) feature classes to display and manage gas network protection.

Anodes and casings are usually related to a pipe. The best way to create these feature classes is to use the predefined Protection Creation workflow.

See also:

- [Protection Creation](#) (page 12)

Anode

An anode is made of a sacrificial material that is more reactive than the material used to make a cathode (for example, a pipe). The anode is electrically connected to the cathode. When an electrical current is passed between the anode and the cathode, the current starts a chemical reaction where the anode, being the more reactive of the two materials, corrodes. This leaves the cathode undamaged.

Anode	Description
Topic	Protection
Table name	GA_ANODE
Shortcut Menu	Workflows: Anode Creation. For more information, see Protection Creation (page 12). Network Pipe Creation. For more information see, Network Pipe Creation (page 5).

Anode Station

A central location where anodes are tested for performance in natural gas systems.

Anode Station	Description
Topic	Protection
Table name	GA_ANODE_STATION

Casing

A casing is a tube which protects cables and/or pipes.

Casing	Description
Topic	Protection
Table name	GA_CASING
Shortcut Menu	Workflows: Casing Creation. For more information, see Protection Creation (page 12). Network Pipe Creation. For more information see, Network Pipe Creation (page 5).

Site

A site consists of one master attribute feature class with related line, point, and polygon geometry feature classes. Each network point can be connected to a site. Sites are not part of the network topology. They are a useful means to group various features of the gas utility network to make them reachable. For example, a site stores house number and location.

Site	Description
Topic	Site
Table name	GA_SITE_*
GA_SITE	Site master feature class that stores the attributes.
GA_SITE_LINE GA_SITE_*	Site geometry feature classes. These store the geometry for graphic presentation and normally do not contain any attributes except graphical attributes like line_type.
Shortcut Menu	Workflow: Site Creation

The easiest way to connect a network point to a site is to use the Network Point Creation workflow. For more information, see [Network Point Creation](#) (page 3).

With the Site or Facility Creation workflow, you can create sites that are related to one geometry feature. Add more geometries and equipment features using the feature class form. For more information, see [Site or Facility Creation](#) (page 8) and [Facility Creation](#) (page 9).

See also:

- [Connect Point Features to Sites](#) (page 54)
- [Connect a Point to a Site](#) (page 25)
- [Remove Connections from a Site](#) (page 26)

Understand and Work with the Gas Data Model

The Topobase gas data model consists of the following components:

Gas Data Model Component	Feature classes
Network geometry	<p>Network geometry is stored in the GA_POINT (for nodes) and GA_LINE (for edges) feature classes. These feature classes store geometry only, not attributes. They are related to the gas features for attribute information.</p> <p>The rows of these tables are managed by the Utility API. Do not enhance geometry feature classes with customer columns.</p> <p>The geometry feature classes build the network topology.</p>
Network topology	<p>Network topology is stored in the _NNOD (topology nodes) and _NLNK (topology links) features classes.</p> <p>Only the point feature classes of the Point topic and the pipe feature class of the Pipe topic are part of the gas network topology.</p> <p>Other feature classes such as the Protection, Site, and Facility topics, the Damage feature class of the Pipe topic, are not part of the network topology.</p>
Gas objects	<p>Gas objects are stored in the GA_POINT.FID_ATTR (utility points) and GA_LINE.FID_ATTR (utility lines) attribute feature</p>

Gas Data Model Component	Feature classes
	classes. These have a relation to the associated point or line geometry feature class.
Control cables	The geometry for control cables is stored in the GA_C_LINE and GA_C_POINT feature classes. Attributes are stored in the GA_C_CABLE and GA_C_CABLE_POINT feature classes. The geometry feature classes build the network topology.
Model tables	Model tables store several types of a particular network item. They are located in the Administration topic under Manufacturer and have the suffix _MODEL. See also Data Model: Model Tables.
Dimensioning	Dimensioning is stored in feature classes with the suffixes, _L (lines), _P (points), and _HL (help lines).
Domains	Domain (page 74) tables have the suffix _TBD and contain lists of available attribute values for combo boxes in forms.
Labels	Label tables have the suffix _TBL and contain feature labels.
Feature Rules	Client-side feature rules customize Topobase behavior. For more information, see Organization of Gas Functions and Features (page 34).

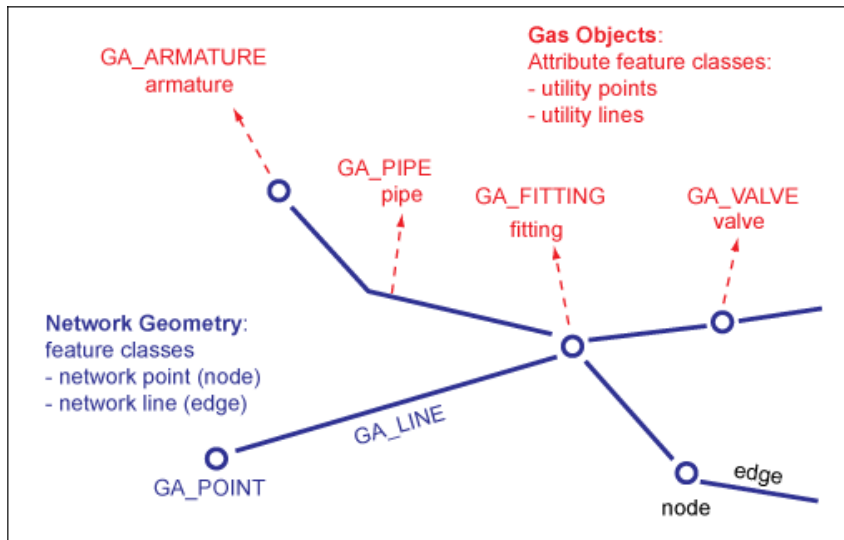

Gas data model

For more information about the data model administrator, see the Data Model Administrator Introduction in the Topobase Administrator Guide.

Explore the Gas Data Model

With the Data Model Administrator you can explore the data model with its topics, feature classes, topologies, and utility models.

To explore the Gas data model

- 1 Start Topobase Administrator and open the Gas workspace.
- 2 Select the document and click Document menu ► Data Model.
- 3 Use the data model explorer to view feature classes, attributes, label definitions and topologies.

To view the gas document structure version

- 1 In the data model explorer, right-click the document root node and click Document Info.
- 2 Click the Gas Data Model row.

The document structure is shown in the lower information pane.

Gas Topologies

The Topobase Gas data model contains the following two topologies:

- **Gas network topology** — Built from the node feature class GA_POINT and the edge feature class GA_LINE. A gas point can be related to a site (FID_SITE).
- **Control cable topology** — Built from the node feature class GA_C_POINT and the edge feature class GA_C_LINE. A cable point can be related to a site and to a control cabinet (FID_SITE, FID_CONTROL_CABINET).

The node and edge geometry feature classes are stored in the Topology topic.

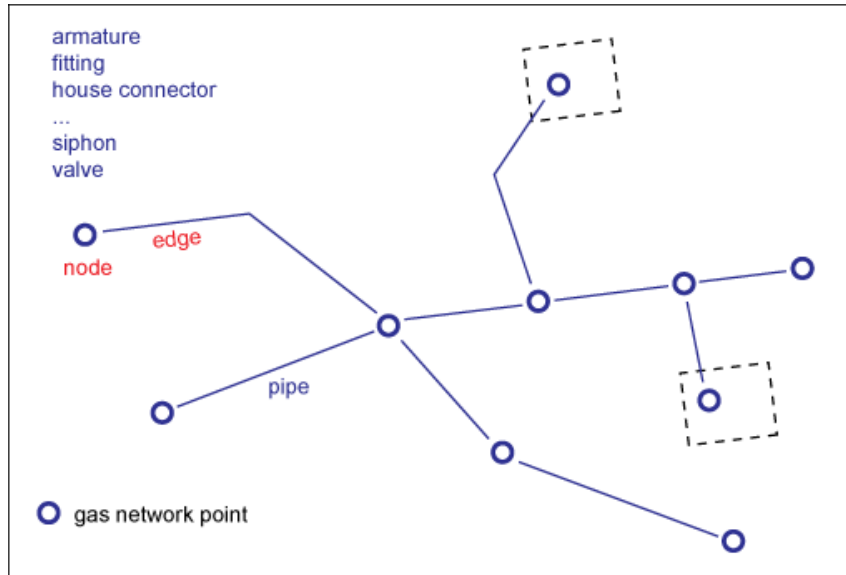

Topobase Gas network topology. Network points are connected with lines. Network points must not lie on a network line.

Achieving a Valid Network Topology

The topology requires that network points always lie at the start or end of a network line. A network point must never lie on a line. If you insert a network

point on a network line, the line must be split at the insertion point. The consistency of the topology is maintained by feature rules.

If a network point is removed, the connecting lines must be merged.

For more information, see [Split Lines](#) (page 29) and [Extract Points from Lines](#) (page 32).

For more information about the feature rules, see [Organization of Gas Functions and Features](#) (page 34).

Define Labels

The basic Gas application contains predefined label definitions for most feature classes. The standard attribute for the label text is called Name Number.

NOTE By default labels are not visible in the drawing. Only labels that are defined as auto labels are created during the create feature operation. Insert labels using

Home tab ► Quick Access panel ► Create Label. 

Example Pipe label — The following label definition is used to display a label containing the diameter, material, and installation date. The label text is queried from the tables GA_PIPE and GA_MATERIAL_TBD.

```
select c.value||' '||a.DIAMETER_NOMINAL||' '||to_char(a.date_in
stallation,'YYYY')
from ga_pipe a, ga_material_tbd c
where a.ID_MATERIAL = c.id
and a.FID = $id
```

Example Armature label — The following label definition is used to display the armature type. The label text is queried from the tables GA_ARMATURE, and GA_ARMATURE_TYPE_TBD.

```
select b.value from ga_armature a, ga_armature_type_tbd b where
a.ID_TYPE = b.ID and a.FID = $id
```

For more information about defining labels, see the [Creating a Label Definition](#) in the Topobase Administrator Guide.

Glossary

area topology Description of spatial relationship between geographic area features. Area topologies contain line strings and centroids. In Topobase™, the polygons are generated automatically from the surrounding line strings. Examples of area topologies are parcels, land use, land cover and political boundaries. See also Topology.

centroid A point that indicates a polygon (approximately in the center). In Topobase, centroids are part of area topologies and belong to the surrounding edges (line string feature class). The centroid normally holds the polygon's attribute data. See also Area Topology.

COGO Abbreviation for Coordinate Geometry. COGO functionality provides calculation routines, such as for intersection, projection, orthogonal survey, offset lines, and right angle course.

Display Manager For stylization in Autodesk Map 3D, applies custom styles to selected features and objects. To view the Display Manager task, select Display Manager in the list at the top of the Task Pane. Also used for stylization of Topobase features.

display model In Topobase, you use display models to administer thematic views. A display model definition specifies which set of layer files (feature layers) is loaded into the Display Manager. Also, the display model defines multi map windows and autoload layers.

document In Topobase, a document is an Oracle® database schema with additional settings in the Topobase System user (database server schema TBSYS). A document is an Oracle database user plus settings for menu bars, toolbars and forms. A document must be assigned to a workspace to be accessible by Topobase Client or Topobase Web. You can create, edit, and configure the documents using the Topobase Administrator.

document explorer Control element in the Topobase Client task pane and in the Topobase Web layout. Use the tree view to show the objects that are stored in the database. For different requirements and more clarity these objects can be grouped into explorer groups. Provides a document-specific

view to process the following objects: Topics (and feature classes), domains, topologies, intersections, system tables, and workflows. You can define a different document explorers for each document. Also called Topobase explorer.

domain Sets of values. For example, a domain defines the values that are allowed for a feature attribute. Topobase data models store domains in domain tables (*_TBD). Domain tables are created using the Topobase data model administrator.

explorer group In Topobase Administrator, a configuration that specifies which objects are to be shown in the document explorer. These settings are saved as Explorer Groups.

feature In Topobase, an entity of a feature class. Each feature in a feature class represents a row or record in the feature class table.

feature class In Topobase, the basic class for objects. For example, a parcel is a feature class. In a database, each feature class corresponds to one Oracle table. A feature class can have any number of attributes (Oracle columns), one of which can be of type "geometry". There are general types of feature classes, such as the following:

- Attribute (feature class without geometry)
- Line String
- Polygon
- Point
- Centroid
- Label
- Compound Polygon
- Compound Linestring

You can group several feature classes for each topic. Each feature class contains many entities/instances or records, which are called features.

feature class form Database form to view and edit attribute data stored in Topobase. Forms can be customized with the Topobase form designer.

feature explorer Control element used to display a set of features in a tree view, resulting from a selection, a validation, or a tracing.

graphic connection A connection between Topobase and Autodesk Map or Autodesk MapGuide to display the features. Topobase Client has a graphic

connection to Autodesk Map. Topobase Web has a graphic connection to Autodesk MapGuide.

job perimeter Spatial area where a job can be processed. You can use job perimeters to control where the modifications of the current job is allowed. Features outside the job perimeter cannot be processed. Also, you can define feature rules to be applied on the objects within the perimeter.

label In Topobase, any attribute data of a feature can be displayed as text, using label features. Label features are generated by arbitrary select statements that can be defined by the customer and therefore are a flexible way to add inscriptions to the objects. Label definitions (select statements and other settings) are stored in the system table TB_LABEL_DEF. Label definitions can be created or edited using the Topobase data model administrator. Label features can be stylized with the Display Manager by displaying the LABEL_TEXT property.

label definition Select statements that create labels. The label definition 1) queries data from the database and 2) specifies positioning and text orientation. This information is used in the Display Manager for stylization.

label feature class Feature class type used to store label features in the database <feature class name>_TBL. Each feature class (parent feature class) can have exactly one label feature class. The label feature class contains default attributes only, and contains no other specific attributes. It stores a relation to the parent feature class.

label placer Places a label to generate a label feature, to write information into the drawing or the map.

logical topology Description of the relationship of features of any feature classes, both attribute or geometry feature classes. The features need not to be spatially connected. For example, a logical topology connects points with points, lines with lines, lines to points, or attribute features to attribute features. Utility networks are based on logical topologies that connect points (nodes) and lines (edges).

For example, a logical topology can represent a waste water network or electrical transmission lines.

master-detail form Type of feature class form where related records are shown in an embedded sub-form on one or more tabs.

network topology See logical topology.

Polygon Object built of line segments that form an enclosed area. In Topobase, polygons are stored in a polygon feature class.

Position Finder Finds the location of a certain object, such as a building, a parcel, or any other type of feature that has geometry. The geometry found will be the center of a graphic generation or a zoom GoTo. There are several types of search such as Sequential search and Flat search.

profile In Topobase, a longitudinal section of line features. A profile is created by projecting features on an axis.

profile data model Data model consisting of a set of profile system tables and an arbitrary set of profile feature classes. Profile system tables store the basic configuration and settings. Profile feature classes store the components of each profile drawing.

prototype drawing Drawing that stores all used blocks, symbols, regular and other lines, text styles and dimensioning styles.

schema plan A schematic diagram that represents real world features by transforming the original feature geometry to an alternative location, for example by applying a coordinate offset. The schema plan represents the real world features in a clear structure, and preserves topology. A schema plan can either be displayed as overlay to the original features, or in a secondary window. You use Topobase Administrator to define schema plans.

schematic feature In Topobase, schematic features are derived from real world features. They are stored in the database and are used to draw the schema plan. Each schematic feature is associated to its real world feature.

TBMAIN Topobase Main User, which is a Topobase System User with restricted rights. The default name for the Topobase Main User is TBMAIN. To start the application, non-administrator users can optionally connect to the Topobase Main User.

TBSYS Topobase System User. Topobase system database schema. Topobase server component that stores application settings and server-side stored procedures. The default name for the Topobase System user is TBSYS. Application users must be connected to the Topobase System user or to the Topobase Main User TBMAIN to start the application.

template In Topobase, a template is an arrangement of recurrent features. The arrangement includes feature attributes, geometry and connectivity. In Topobase Client, you use templates to place a feature arrangement in one single step.

topic In Topobase, a group of several feature classes. A topic is a collection of feature class tables. Topics can be thought of as containers used to organize feature classes. Considering a data transfer, topics are fully independent of one another. Each topic may have sub-topics.

To build a clear and transparent data structure, you can group feature classes into topics, group several topics into main topics, and define feature classes with sub-feature classes. These relations between topics and feature classes serve only as an illustration of the data structure. There is not necessarily an actual relation between the tables.

Topobase Administrator A Topobase basic module, used for Topobase administration. Topobase Administrator contains several components, such as:

- Topobase data model administrator
- Topobase form designer
- Topobase report designer
- Topobase job administrator

Topobase Client A component of Topobase Administrator, used for registering and processing data stored in Topobase through forms and using Autodesk Map for graphic processing.

Topobase data model administrator A Topobase module used to process and establish data structures (topics, tables, attributes, topologies, and intersections) in Topobase. Also, you can define label definitions and dimensioning.

Topobase job All changes in the Topobase data pool can be controlled and performed by exact reports on appropriate processing steps, if they are performed inside a job. Using jobs allows you to control the version. A job includes various processing states (live, pending, project). For each processing state, an application exactly defines which actions are allowed.

Topobase System User Database schema that stores application settings and server-side stored procedures. Default name is TBSYS. Application users must be connected to the Topobase System User to start the application. They can either connect directly to the Topobase System User or use a Topobase Main User which has restricted rights. See also TBSYS and TBMAIN.

Topobase Web The web version of Topobase applications.

topology A geometric shape property in which metrical relations play no role. Topology describes how lines, nodes, and polygons connect and relate to each other, and it forms the basis for spatial analysis as network tracing. In Topobase, topologies can be administered within individual groups of feature classes. They can be defined with the Topobase data model administrator.

topology checker Tool to check topologies. The results are displayed in a tree view, displaying all feature errors.

user A person who works with any Topobase application. Each application user belongs to a group called a user group, with certain tasks and rights. Examples of users: Mr. MILLER, Mr. SMITH, Ms. BAKER; BILLY, TONY, LARRY.

user group A group of users having certain task and rights. Examples of user groups: ADMIN, VIEWER, EDITOR, and so on. A member of a user group can access workspaces only if he has a permission. He may use certain tools and functions and he has certain rights to edit or view the data.

utility model Topobase data model component for utility applications, which provides feature classes and rules for utility networks.

viewport Area of interest for the generate graphic process. A Topobase viewport is a spatial filter on the map.

workflow In Topobase applications, a guide for the user through tasks like acquisition, analysis, and reports.

workspace The central workflow unit in Topobase. For different user groups, such as EDITOR, VIEWER or ADMIN, you can define the appropriate workspaces, with respective roles and rights. A workspace comprises one or more documents.

From the user's point of view, a workspace is the starting point of his work. He must open a workspace to work with any Topobase application. By selecting a workspace, he will load all necessary objects, including the appropriate menus and toolbars, with a single mouse-click. Therefore, he can even access data from different applications, such as land management and wastewater, in arbitrary combinations.

Index

C

create features
gas 3

D

data model
gas 68

F

facility management
gas 46
feature rules
gas 41
Topobase gas 34

G

gas
create features 3
data model 68
feature functions 22
introduction 1
label definition 72
topology 71
workflows 2

I

introduction
gas 1

L

label definition
gas module examples 72

M

manage
gas network topologies 20

N

network topology
digitize points 3
extract points 32
split lines 29

P

points
extract from lines 32
pressure zone 11
gas 39

R

report generation
wastewater 19
reports
gas 20

S

split lines
gas 29
soft and hard split 30
supply zone
gas 39

T

topologies
managing gas network 20

topology
 gas network 71
 keep - consistent 32

W

wastewater
 report generation 19
workflows
 gas - 2