

AutoCAD® Civil 3D® 2008
Autodesk® Vault

AutoCAD Civil 3D 2008: Project Management Workflow Using Autodesk Vault

With Autodesk® Vault software, the comprehensive data management tool included with AutoCAD® Civil 3D® 2008 software, your civil engineering teams can work together to complete projects more quickly and efficiently. By supporting version control and allowing your teams to store and share all types of engineering files and related data, Autodesk Vault enables a secure, collaborative work environment. This white paper details how your teams can set up Autodesk Vault and outlines a suggested AutoCAD Civil 3D/Autodesk Vault workflow that you can use to work more efficiently, complete projects faster, and reduce risk of errors.

Contents

Introduction	3
Autodesk Vault Architecture	3
Setup	5
Implementing Autodesk Vault	5
Organizing Your Projects.....	6
Working Folders.....	8
AutoCAD Civil 3D 2008 Project Interfaces	10
Prospector Toolspace.....	10
Vault Explorer	10
Microsoft Office.....	12
Backup Procedures.....	12
Creating an Efficient Project Management Workflow.....	13
Level 1: Creating Individual Design Objects	15
Level 2: Creating Base, Linework, and Engineering Drawings	17
Level 3: Creating Top-Level Production Sheets	18
Conclusion	20

Introduction

Because your civil engineers typically work in teams, you need an effective workgroup data management solution that enables your engineers to collaborate efficiently. Integrated into Autodesk® Civil 3D® 2008 software, Autodesk® Vault is a data management system for sharing design data across project teams. Autodesk Vault allows you to manage not only DWG™ files, but all of your engineering and related data, such as hydraulic designs, analyses, and data generated from Microsoft® Office applications or other design software.

As a comprehensive file management and version control solution, Autodesk Vault provides an effective way for your engineering teams to simultaneously share design objects within the same project. It includes a server component that acts as the database and provides administrative tools, and a client component that includes AutoCAD Civil 3D and a stand-alone file system management tool called Vault Explorer.

With Autodesk Vault, your data stays secure and is less likely to be unintentionally corrupted because you determine who can edit data versus who can simply view it. By providing multiple team members with parallel, controlled access to designs, Autodesk Vault helps you maintain data integrity across large and complex projects. With Autodesk Vault, your project teams can have the ability to work more efficiently, complete projects faster, and reduce the risk of errors.

This white paper describes how your civil engineering teams can use Autodesk Vault to share design data, manage complex revisions, and collaborate more effectively on civil engineering projects. The paper details recommendations for setting up Autodesk Vault, managing project data using Prospector Toolspace and Vault Explorer, and backing up project data. It also illustrates how Autodesk Vault can help you create a more efficient workflow in AutoCAD Civil 3D. First, let's take a brief look at the architecture of Autodesk Vault.

Autodesk Vault Architecture

In its simplest terms, the Autodesk Vault architecture is made up of Vault Server and the Vault Client, with a web server that handles the communication between the two (see Figure 1).

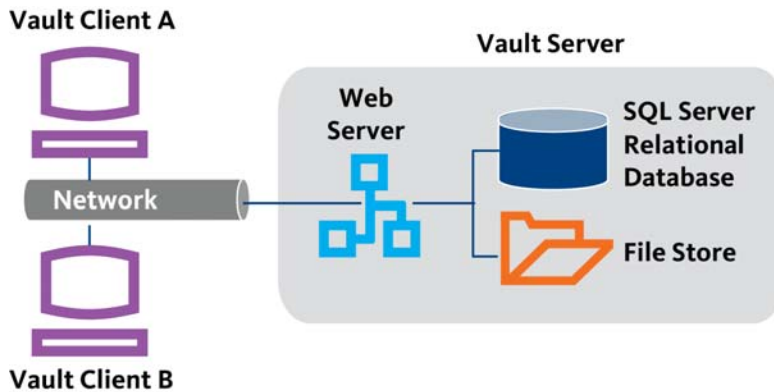

Figure 1. Autodesk Vault architecture.

Vault Server: Also referred to as the Autodesk Data Management Server, Vault Server is a secure repository for project data that is external to AutoCAD Civil 3D. Vault Server is a combination of a relational database, a file store, and a web server. The relational database manages version history, purpose and content of revisions, user and group access privileges, and metadata, and it indexes the files contained in a project. The file store contains all versions of all files stored on the server in the master data files (the source files containing all the project data). The web server is the communication component between the Vault Server and the Vault Clients.

Vault Client: The Vault Client is made up of Vault Explorer and AutoCAD Civil 3D. Vault Explorer is a stand-alone application based on the familiar Windows® Explorer interface. It allows you to manage project files in the Vault Server. In AutoCAD Civil 3D, the Prospector Toolspace includes a Projects node, which is used to manage, edit, and share drawings and design objects in the Vault Server.

For more in-depth information on these components, please access the Autodesk Data Management Server *Implementation Guide* included in AutoCAD Civil 3D. The default location for this guide is C:\Program Files\AutoCAD Civil 3D 2008\Help\ADMS_2008_ImplementationGuide.pdf.

Beginning with AutoCAD Civil 3D 2008, you can configure Autodesk Vault for multisite use (see Figure 2). This is an extra-cost option that enables work groups in different geographic sites to share project data in one database. A single SQL instance manages the drawings and other data for all sites, replicating and updating files from one local file store to another as needed. The system can be administered from any site, although these tasks are typically handled by the home site.

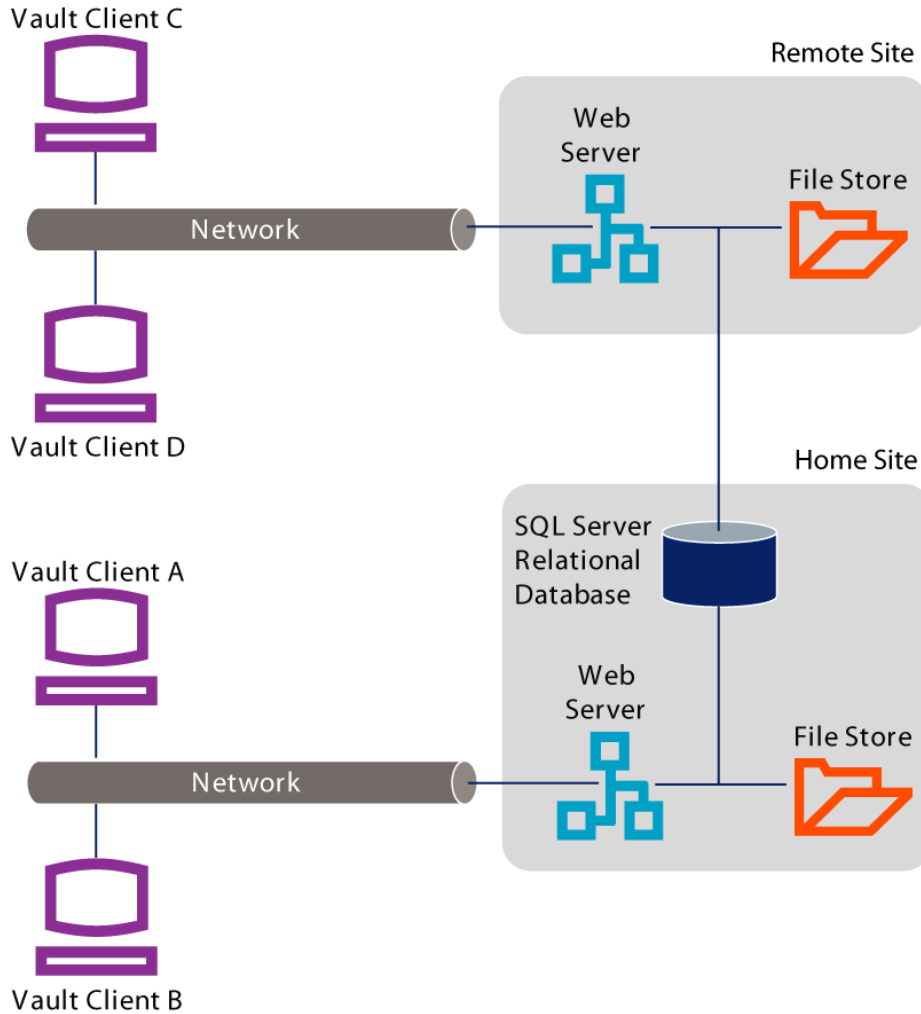

Figure 2. Autodesk Vault multisite architecture

Setup

By implementing Autodesk Vault, your project teams can access the data they need to complete their work. This section will outline how to:

1. Meet implementation requirements
2. Partition data
3. Set up working folders

Implementing Autodesk Vault

Vault Server (referred to from this point forward as Autodesk Vault) stores the master data files of all design information and automatically installs Microsoft® SQL Server™ 2005 Express. This server is intended for smaller work groups, and does not support more than 4 GB of metadata per vault. If your database grows beyond this capacity, you can upgrade to the full version of Microsoft SQL Server 2005 (Workgroup, Standard, or Enterprise Edition), which is available separately from Microsoft or a Microsoft reseller.

You are not required to purchase a new server to install Autodesk Vault, however, we advise you to use a dedicated server or workstation if possible. Your hardware should meet the recommended requirements, including an Intel® Pentium® 4, Xeon®, or AMD Athlon® 2-GHz processor; 1 GB or more of memory; and 60 GB of free disk space. The system you install Autodesk Vault on should also include a CD or DVD drive, an Internet connection for web downloads and subscription-aware access, and Microsoft Internet Explorer 6 SP1 or later.

Autodesk Vault can be installed on the following 32- or 64-bit operating systems:

- Microsoft Windows XP Home (SP2)
- Microsoft Windows XP Professional (SP2)
- Microsoft Windows 2000 Professional (SP4)
- Microsoft Windows Vista (Ultimate, Enterprise, or Business) 3
- Microsoft Windows Vista Home (Premium or Basic)
- Microsoft Windows 2000 Server 2 (SP4)
- Microsoft Windows 2003 Server Standard R2 or 2 (SP1)
- Microsoft Windows 2003 Server Enterprise R2 or 2 (SP1)
- Microsoft Windows 2003 Server Small Business Edition R22 or 2

Autodesk Vault is included with your purchase of AutoCAD Civil 3D. Unless your system fails to meet the basic requirements above, you do not need to upgrade or purchase additional hardware or software to run Autodesk Vault. There are no other costs to get Autodesk Vault operational.

Organizing Your Projects

Autodesk Vault can be set up in a variety of ways, so you can manage and store your projects in the manner that best meets your business needs. Below you will find information on two ways—a single vault versus multiple vaults—to organize your AutoCAD Civil 3D projects within Autodesk Vault.

Single Vault

The most common way to organize your projects with Autodesk Vault is in a single database—also referred to as a “vault”—to store all projects and their information. The use of a single vault is the simplest configuration. You just create one vault database on the server and store all AutoCAD Civil 3D projects in that database. All team members have access to this database, and you set up access control and user names only once. By using a single vault to house all projects, you centralize project access for all team members, making it easier to find project data.

Multiple Vaults

The use of multiple vaults is advisable whenever you want to completely isolate one set of projects from another, and there is little or no need for data sharing between the two. For example, you could have vaults for separate departments in your organization, or vaults for separate project types. Each vault is managed separately, with its own users, permissions, and backup schedule.

In some cases, it may be advantageous to partition your data into multiple vaults on the same server. For example, you may choose to keep projects organized by year, in which

case you would create a vault for every year. Thus, you could have several office locations with their own Autodesk Vault to log onto, with the following hierarchy:
Location > Year > Project

- > Jackson (Vault Server office location)
 - > 2006 (One of several vaults, denoted by year)
 - > J06068 (The project name that employs the “J” prefix to denote which office originated the project)

Organizations with very large, multi-phased projects may want to assign a separate vault for each project for ease of project management. If you elect to partition your data into multiple vaults on a server, your project teams will experience shorter project lists and tighter control over data access. However, there are some disadvantages. Projects reside in different locations and your users have to remember multiple vault names and locations. Also, backing up and maintaining multiple vaults is more work for your IT department.

Project Folders and Templates

Within a vault, data is divided into project folders. As a best practice, each project should have a consistent structure of subfolders, making it easier to manage and locate data. The folder structure shown in Figure 3 exists as a project template in AutoCAD Civil 3D that you can apply to every new project.

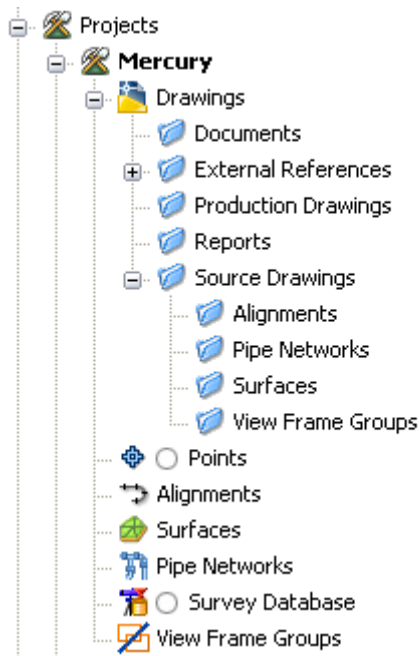

Figure 3. Standard project template

If this template is not entirely suitable, you can create customized project templates and save them for future use.

Data Security and User Groups

One of the duties of an Autodesk Vault system administrator is to create user accounts and assign access permissions. As shown in Figure 4, each user can have the role of an administrator, vault editor (read-write access), or vault consumer (read-only access). Content Center roles do not apply to Civil 3D. User roles apply



Figure 4. Defining permissions for a team member.

to the entire contents of the vault, but access can be restricted at the folder level. For example, a vault editor can be granted read-only access to a particular project, and no access to a certain folder within that project. For ease of management, it is a best practice to create user groups, and assign each user to a group. Then you can assign access permissions to the group, and these apply to everyone in the group. For example, a project might have a set of groups and permissions as shown in the following table:

Group Name	Write Access to	Read Access to	No Access to
Surveyors	Surfaces Reports	Alignments	Documents
Design Engineers	Alignments Pipe Networks View Frame Groups External References Reports	Surfaces Documents	
Data Technicians	Production Drawings View Frame Groups	Reports	Documents
Project Managers	Reports Documents	Alignments Pipe Networks	Surfaces External References

If a user's work responsibilities change, the system administrator can move that user to another group, or modify their permissions individually.

Working Folders

When you work on particular design objects, such as road alignments or pipe networks, you check the associated drawings out of a vault and work with them in working folders (the location where checked-out or open work-in-process is stored). Working folders mirror the project folder structure in Autodesk Vault (see Figure 5). When you check out or get files from a project, they are physically copied from the file store to the working folders and then tagged as "checked out" in Autodesk Vault. You can then edit the files from within the working folders, with the assurance that while other users can still get read-only copies of the files, they cannot check them out for editing until you have checked them back in. This way, you maintain a single version of each drawing while still allowing team members to share data within the drawing.

When you check a file back into a project, Autodesk Vault copies the revised version from your working folder to the File Store on the server. Autodesk Vault marks the file with the appropriate revision data and makes it available to other users.

You can change the location of the working folder by accessing the Prospector Toolspace from AutoCAD Civil 3D and selecting "Set Working Folder." If your project manager or administrator has already enforced a specified location for a working folder, any custom location is overwritten.

Setting Up Working Folders

You have three options for setting up working folders, as shown in Figure 6. Individual users on a project can have their own working folders on their desktop computers (Figure

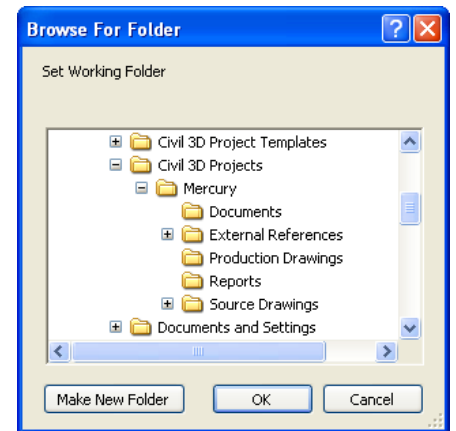

Figure 5. Working folders mirror the project folder structure in Autodesk Vault.

6a); everyone in the organization can share a working folder on the server (Figure 6b); or each user can have a dedicated working folder on the server (Figure 6c). Let's look at each option.

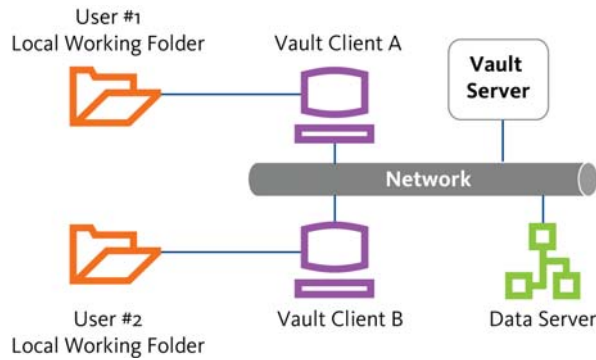

Figure 6a. Individual local working folders.

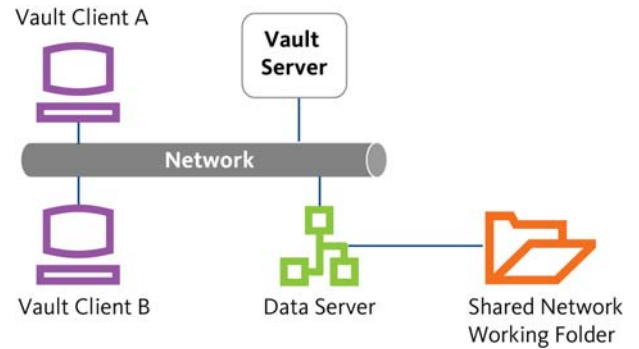

Figure 6b. Shared network working folder.

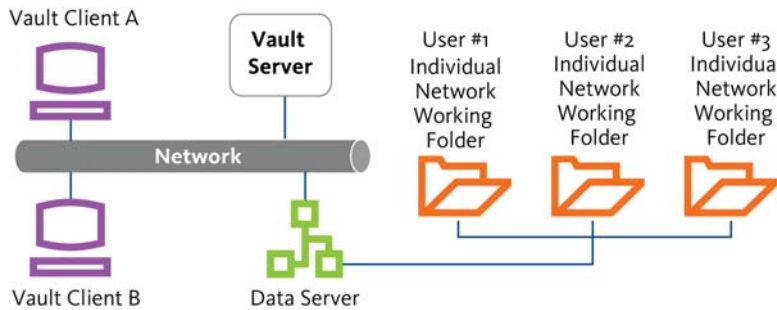

Figure 6c. Individual network working folders.

Working folders on individual users' local computers

When working folders are kept on local computers (Figure 6a), it minimizes network traffic and accommodates team members who may work offline from the field or a home office. By setting up working folders locally, users create network traffic only when they check in, or check out files from the vault. The disadvantage of this option is that the project files are stored on the local machine, which makes them unavailable for the backup system. In addition, using external references (xrefs) and Sheet Set Manager (SSM) to share files is a more manual process. This set-up also requires more storage capacity on the local machines, as the project files that users check out are copied locally.

Individual working folders on the server

By maintaining private working folders on the server (Figure 6c), you secure each individual's work-in-progress from other users who may be less familiar with the proper means of interacting with Autodesk Vault data. Locating these folders on the server also allows for nightly backup of the data. The drawback to having individual network working folders on the server is the increase in network traffic. Additionally, if you do a nightly backup of the folders, you may have a lot more data than you really need, as you may back up multiple copies of the same files in each folder.

Working folders on the server in a common folder

With this approach (Figure 6b), all users in your organization would access a common folder on the file server when checking out and modifying files. It may also be more familiar, as many organizations already use a centralized data or projects folder for their drawings. Similar to individual working folders located on the server, a shared working folder can be backed up nightly, to maintain project data security. However, since it is a common location, the backups will be smaller in size than with the backups of individual working folders. The benefit of this approach is that drawings with data references or external references will be notified and updated every time they are saved, rather than only when they are checked back into the vault, as with the other two options. The drawbacks to having a common working folder on the server are the increase in network traffic and the inability of users to take full advantage of securing data as they can when using local working folders.

AutoCAD Civil 3D 2008 Project Interfaces

To work with an AutoCAD Civil 3D 2008 project stored in Autodesk Vault, you can access one of two interfaces: the Prospector Toolspace in AutoCAD Civil 3D, or Vault Explorer. Often you can use either for a specific task, but in certain situations there are distinct advantages to using either Prospector Toolspace or Vault Explorer. You can also perform certain functions, such as checking in files, from some Microsoft Office applications. We explore the function of each of these interfaces below.

Prospector Toolspace

We recommend that you use Prospector Toolspace within AutoCAD Civil 3D to create all projects. After creating a new project, it will show up in the Projects tree in AutoCAD Civil 3D. You can also view, edit, and manage drawings and AutoCAD Civil 3D object data stored in a vault with Prospector Toolspace, as shown in Figure 7.

To work on a drawing, you use the “Check Out” command in Prospector Toolspace to copy the files to your working folder and open it for editing in AutoCAD Civil 3D. After you’ve finished working on the drawing, you use the “Check In” command to save changes to the master folders in the file store. If you need to view a file without editing it, you can use the “Open Read Only” command. To save a new file to a project, you choose “Add to Project” in Prospector Toolspace.

Once a project has been created using Prospector Toolspace, and a project template, you can add more folders to the project folder structure, if necessary. There are two methods for doing this. The first option is to simply use Windows Explorer to create the new folders in your working folder. As data is saved to these folders, and consequently checked into the project, the folder structure is automatically added to the vault. The second option is to use Vault Explorer (see below for more detail) to log into the vault and create the folders. Either way, it is easier for users to find and access files if you maintain a consistent folder structure throughout all company projects. A consistent structure also facilitates system administration.

Vault Explorer

Vault Explorer is a stand-alone application that allows you to manage project files in a vault—from outside of AutoCAD Civil 3D. The Vault Explorer window, shown in Figure 8,

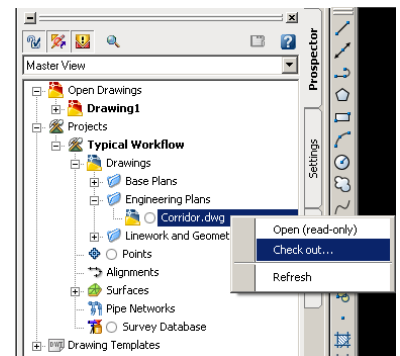

Figure 7. Check out a drawing through the Prospector Toolspace in Autodesk Civil 3D.

resembles the Windows Explorer window, listing projects as folders. In the Vault Explorer window, you can see a list of all versions of a selected file—whenever a file is checked in, the version number automatically increases by one—and view all external file dependencies occurring in the file. This often includes externally referenced drawings, images, XML surfaces, and AutoCAD® Land Desktop software’s Triangulated Irregular Network (TIN) and PNT surface files.

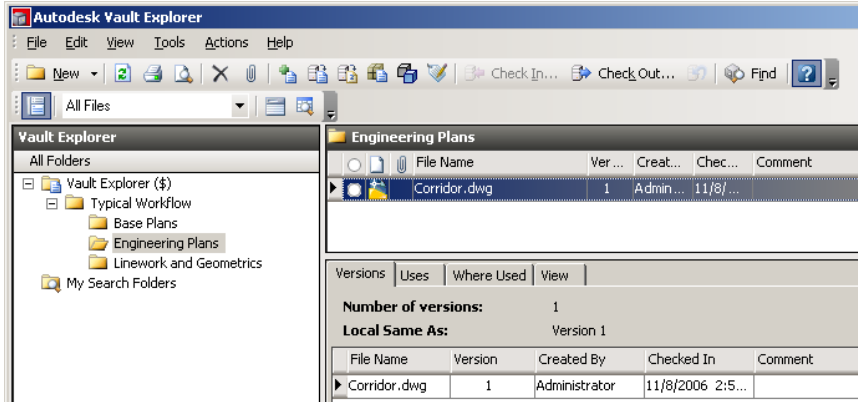

Figure 8. Vault Explorer window.

The Vault Explorer window also lists all drawings where the selected file is used as a reference and displays DWF™ versions of the drawing files, so you can quickly find the version you need.

You can use Vault Explorer to conduct many administrative activities. Your Autodesk Vault administrator can set up your working folders and enforce their location—such as individual folders on the server, shared ones on the server, or folders on individual computers.

As described in “Data Security and User Groups,” you can use Vault Explorer to create the user accounts and access permissions that define your security system.

Using Vault Explorer, you can also easily restore a previous version of a file—a helpful process when a client decides to go back to an earlier design iteration—without restoring the entire project. If you need to start a new drawing using an existing drawing as the basis, you can use Vault Explorer to do this without opening the source drawing. It's as easy as right-clicking on a drawing name, selecting the “Copy Design” option, assigning the drawing to a project, and naming the new drawing.

Vault Explorer also lets you label project milestones for easy identification. This can be handy if you need to submit deliverables to a client at certain levels of completion, such as 30%, 50%, and 75%. For a 30% complete submittal, you can label all drawings in a project “30%.” When you create this new label, the most recently checked-in version of every file in the project and all reference files are assigned the label. If, at a later time, you need to restore the 30% completion project files, you can easily restore the project to this milestone by simply restoring the 30% label, instead of doing it drawing by drawing.

Another helpful Vault Explorer task is “Pack and Go,” in which a label and all of its referenced files are combined into a single package and sent to either a folder outside the vault or to an e-mail recipient. All files referenced by a selected label are automatically

included in the package unless otherwise specified. You can use Pack and Go functionality to archive a file structure, copy a complete set of files while retaining links to referenced files, isolate a group of files for design experimentation, or send a data set to e-mail recipients, such as a subcontractor or client.

Because Autodesk Vault allows you to store every electronic file related to your project—such as Word documents, e-mails, spreadsheets, and design outputs from third-party applications—you should also use Vault Explorer when you need to manage files that are not AutoCAD Civil 3D drawings, or not based on AutoCAD® software.

We do not recommend using Vault Explorer to check in or check out drawings with AutoCAD Civil 3D data. In the rare case that these drawings do need to be managed—for instance, an engineer quitting while having files checked out of a project—your administrator can force a check-in of the files through Vault Explorer.

Microsoft Office

You can also access Vault from within Microsoft® Word, Microsoft® Excel®, and Microsoft® PowerPoint® applications. This is convenient for managing project spreadsheets, presentations, and other documents created with Microsoft Office applications. If you want this functionality, you must have Microsoft Office installed on the same computer as AutoCAD Civil 3D and the Autodesk Vault client. You also need to have the MS Office Add-In for Vault installed with the Autodesk Vault client. The Add-In is available when you install AutoCAD Civil 3D if you select the custom install option. But if you have already installed Civil 3D and Vault, you can install the MS Office Add-In by using the Add/Remove Programs option. Just select Autodesk Vault as the program, and then in the Installation Wizard, select Add or Remove Features. When everything is installed correctly, the File menus for Microsoft Word, Excel, and PowerPoint are automatically customized. An “Open from Vault” command and an Autodesk Vault submenu are both added to each File menu, as shown in Figure 9. Using these, you can log in to Autodesk Vault and check documents in and out of Vault from within the Microsoft applications.

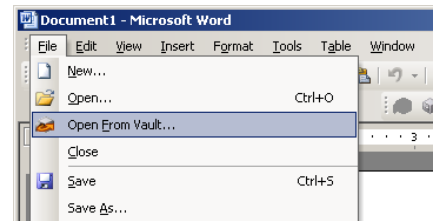

Figure 9. Access Autodesk Vault from within Microsoft Office applications.

Backup Procedures

It is critical to correctly back up your project data—otherwise you put your project at risk when there is an unforeseen event, such as an accidental deletion, file corruption, or power outage. Because of the live SQL database Autodesk Vault employs, you cannot back up Autodesk Vault data using a tape backup device on the Autodesk Vault database and file store.

To back up your data, use ADMS Console, a set of tools within Autodesk Vault for maintaining users and vaults. Using ADMS Console's backup routine keeps the database and file store in sync with each other. You will need the user name and passwords of your Autodesk Vault administrator to run the backup process. After the backup is complete, you can direct your tape backup system to the Autodesk Vault backup directory for archiving. To make backups easier, you can use a script to have this procedure automatically occur on a regular basis.

Because your drive space may be limited, you may occasionally need to purge old file versions. For example, if you use Microsoft SQL Server Desktop Engine, the size of your relational database cannot exceed four gigabytes. You should keep everything that you may need to reference later, as well as some versions for archival and milestone

purposes. To allow adequate drive space, you may want to institute a process for purging old files at set intervals based on your firm's workload.

To purge your data, use the purge routine built into ADMS Console (see Figure 10). You can purge a certain number of versions, purge versions older than a given number of days, or exclude versions with a specific notation.

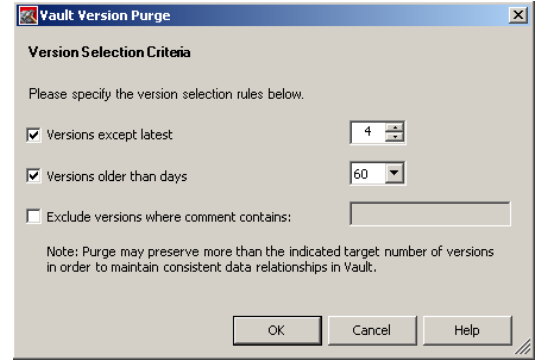

Figure 10. Vault Version Purge.

Creating an Efficient Project Management Workflow

For most civil engineering projects, multiple team members need parallel access to design data. With Autodesk Vault, you protect data sharing throughout the project lifecycle and streamline the design process. Your team stays coordinated, and each member gets the project data they need without having to wait for the next person to finish. Below, we document a suggested workflow using AutoCAD Civil 3D and Autodesk Vault to help your teams work collaboratively, and efficiently.

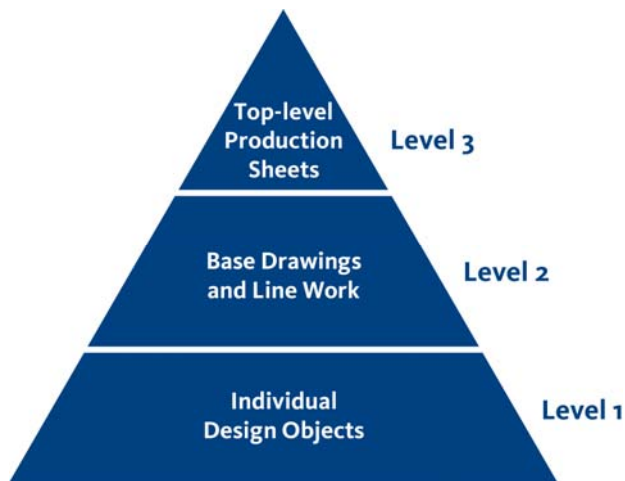

Figure 11. Framework for a proposed workflow

This workflow consists of three levels as illustrated in Figure 11. In Level 1, you create individual design objects, such as alignments, surfaces, and pipe networks in separate drawings. These provide the foundation on which the rest of your project is built. After you create your design objects and check their drawings into a vault, you use data references to reference these objects into base drawings in Level 2. Each data reference points to a design object in a drawing. These references can be loaded into other drawings, creating a copy of the object that a user can stylize and use for more design work, but can't edit. The use of data references allows you to safely share your design objects across multiple drawings. When you edit a design object, drawings that reference the design object are also updated.

For example, you would design all of your individual alignments in Level 1, and then data-reference them in Level 2 to create a geometric base drawing. The same relationship would exist for objects like surfaces (Level 1) and topographic plans (Level 2), as well as pipe networks (Level 1) and a utility base (Level 2). It is also important to note that you need to combine data references and external references (xrefs) in order to include all

project information in your drawings. For example, to create a proposed alignment and profile drawing, you would need to combine a data reference of the existing ground surface with an xref of the existing conditions plan (containing AutoCAD entities).

Once you have checked the Level 2 base drawings into a vault, you can create a production sheet (Level 3), such as a plan and profile sheet, by using xrefs to combine the base drawings. By maintaining this drawing structure, whereby the individual design objects provide a foundation for base drawings and production sheets, you can take maximum advantage of the dynamic model that is integral to AutoCAD Civil 3D. That is, when a change is made to any of the objects in Level 1, it is automatically reflected in your Level 2 base drawings and Level 3 production sheets.

By using this workflow, you also take advantage of the AutoCAD Civil 3D dynamic link between labels and referenced objects. This enables all your annotation to be synchronized throughout all the drawings in the project. Let's explore each level in this workflow in more detail, using Figure 12 as a reference.

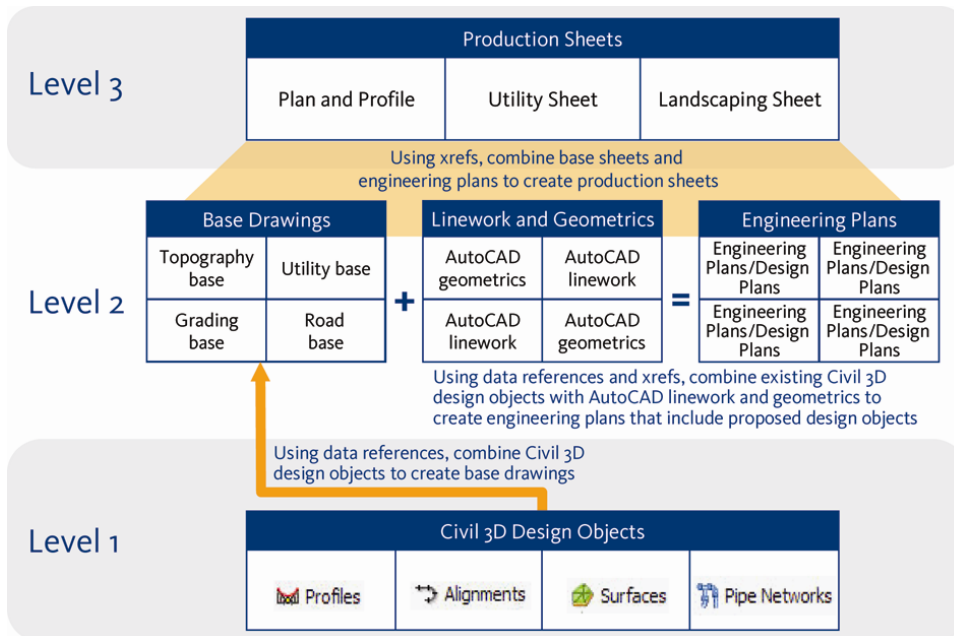

Figure 12. Combine design objects in Level 1 to create base drawings in Level 2 using data references. Combine design objects with linework and geometrics to create engineering plans in Level 2. Combine base sheets and engineering plans to create production sheets in Level 3.

Level 1: Creating Individual Design Objects

In the first level of the workflow (Figure 13), you can set up the source drawing—the drawing in which the object is created and stored—in one of two ways. You can either create one object per drawing or you can include several objects in a single drawing. Let's explore these two options as well as the factors you should consider when deciding which option to use.

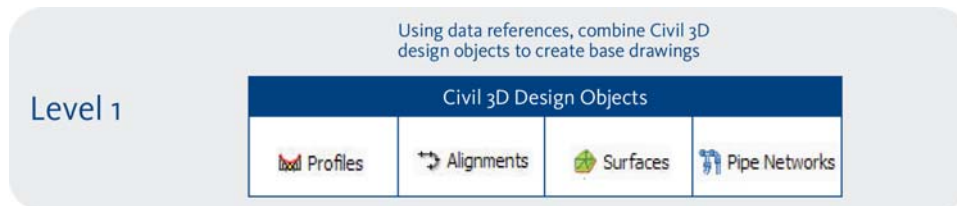

Figure 13. Level 1, design objects.

One Object, One Drawing

In this scenario, you save each design object in its own drawing. If you know that team members will have to share or edit an object at the same time, we recommend that you adopt the one object, one drawing practice. Autodesk Vault controls data-sharing using the source drawing from which a design object is created. If you place two or more design objects in the same source drawing, only the user who has checked out the drawing from a vault can edit the design objects. In effect, a drawing locks up any design objects contained in it, so that only the user who has checked it out can make changes.

Therefore, to allow multiple people to edit multiple design objects, you need to place the objects in separate drawings. For example, if your project design has five alignments and multiple team members need to edit these alignments simultaneously, then you need to store each alignment in its own drawing. By doing so, each team member with write access can edit the alignments as needed, while other team members can still concurrently reference the alignments for other design tasks.

This one-object, one-drawing approach allows you to continue to share objects collaboratively among team members, a practice that may be familiar to your team if they've used applications such as AutoCAD Land Desktop. The main difference is that with Land Desktop, anyone working on a project can edit objects. With AutoCAD Civil 3D and Autodesk Vault, you can set roles and permissions for individual users defining what actions they can take. By using the one-object, one-drawing approach in Civil 3D, you enable as many people as possible to work simultaneously on projects in a secure way. The extra time it takes to create and name a new drawing for each new design object is minimal—and you gain the ability to keep your project progressing quickly.

An exception to the one-object, one-drawing rule applies when you are creating a profile or vertical alignment and you wish to add it to the project. If you want to share a profile with other drawings as a separate object, you need to put the profile in the same drawing as its parent alignment. If you don't need this capability, you can create a profile in a separate drawing as with other design objects.

Multiple Objects, One Drawing

If you have only a few team members who will edit a design, you do not need to follow the one-object, one-drawing practice. You may choose to keep some design objects together in a source drawing when creating a Level 1 drawing. For example, if you have several

pipe networks in your design, but only one person on the design team is responsible for designing and editing these, then you can store all the pipe networks in the same drawing. When that drawing is checked into the project, all of the pipe networks are available for reference by other team members. Taking this multiple-objects, one-drawing approach can reduce the amount of drawings in a project and provide a single source for editing.

Other Considerations

There are several guidelines you should follow when managing drawings in Level 1 of the workflow. These practices apply regardless of whether you use the one-object, one-drawing or multiple-objects, one-drawing approach.

For each drawing you create, you will assign a unique file name and save it to the designated project working folder in Autodesk Vault (see page 6-8 for a discussion on setting up the project folder structure). We recommend that you do not use the default file names. Instead, provide a unique name for each drawing with a clear reference to the object it contains (for example, *Maple_Street_Centerline.dwg*). To check your drawing and object data into the vault, you'll use the "Add to Project" wizard that is part of AutoCAD Civil 3D (see Figure 14). This wizard guides you through the entire process. Consider the following options when checking in your drawing:

- Check in not only your drawing, but all file dependencies as well (this may include xref drawings, LandXML files, TIN files, etc).
- Leave on the option to "Keep Files Checked Out" if you want to save the drawing to a vault, but continue to work on it.
- Create a DWF snapshot of the file so you can quickly see its contents should you need to find the drawing several revisions later.
- Add a version comment that may help you remember the attributes of the version (for example, noting whether a survey has taken place, or including the date).
- Select the object as "shareable," so that other team members can use a reference copy of the object in other drawings.

Repeat the process of creating, saving, and checking in design objects as described above. After you have created your design objects—either each in its own drawing or several in a single drawing—you can data-reference them to create base plans, such as a utility base or grading base, or combine them with externally referenced AutoCAD linework and geometrics to develop proposed design objects—tasks that happen at Level 2 of the workflow and will be explored in more detail below.

Survey Data

AutoCAD Civil 3D uses a unique database called the Survey Database to store, manage, and edit survey information (see Figure 15). This database is created outside the Autodesk Vault environment, but is stored in the working folder with all other project data. When you need to add survey data to your project, simply check the database into the project. This will make all of the points, figures, and observations stored in the database available for use by other team members. You can manage the survey database once it is checked into a project using the AutoCAD Civil 3D Prospector Toolspace.

Once you have the Survey Database checked out, follow these steps:

1. Open the Survey Database from the Survey Toolspace.
2. Add survey data by importing or manually creating it.

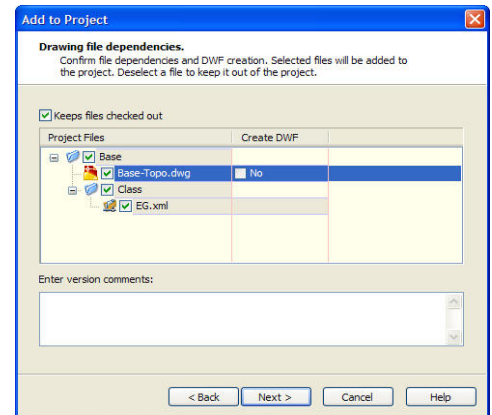

Figure 14. Keep file dependencies when using the "Add to Project" wizard.

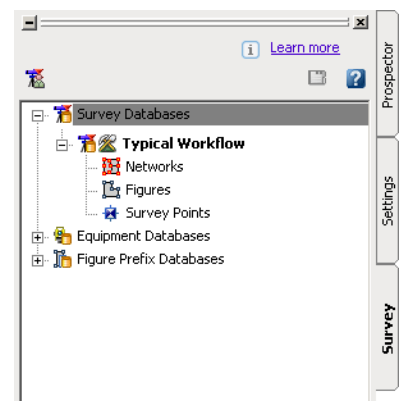

Figure 15. Project Survey Database

3. Close the Survey Database from the Survey Toolspace.
4. Check the Survey Database back in to the survey project using Prospector Toolspace.

Points

Like survey data, points are not stored in a source drawing and must be managed differently than other design objects. Master copies of points are stored in a point database within the project database. Project points are checked out or copied directly to a drawing. Because the project database does not display individual points, you cannot view them using Vault Explorer. However, you can check out, modify, and check in individual project points or point groups. When you modify and check back in a point or a point group, the project database updates automatically.

Level 2: Creating Base, Linework, and Engineering Drawings

After you've created your design objects and checked them into a vault, you can create several types of drawings in Level 2 of the workflow. These include base, linework, and engineering drawings.

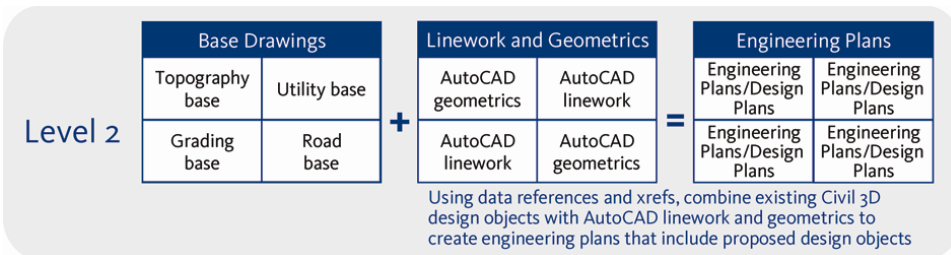

Figure 16. Level 2, create engineering plans and base drawings.

Base Drawings

Base drawings are created by combining AutoCAD Civil 3D objects that are data-referenced from Level 1. You can then use base drawings as external reference files for site features plans or for plan sets, such as an existing condition drawing that includes survey data and a surface model.

Linework Drawings

Creating linework drawings is sometimes an intermediate step between developing engineering plans and base drawings. Linework drawings contain the linework and straight AutoCAD objects (such as lines, text, and blocks) that are used to build or represent existing conditions. Although linework drawings do not include AutoCAD Civil 3D objects, it is a good idea to add linework drawings to the project so that you can manage and reference them later on in the workflow.

Engineering Plans

Engineering plans—such as corridor designs, grading plans, or site plans—result from combining design objects to create or “engineer” other design objects for your project. For example, if you want to design a corridor model, you can create a drawing that references—from Autodesk Vault—both an alignment with its profile and the existing ground surface. With engineering drawings, you take advantage of the work done on objects in Level 1 while leveraging the powerful AutoCAD Civil 3D design tools. In a multi-user environment, engineers and designers are able to reference core objects from the

project, while at the same time, technicians and drafters can create plan sets and conduct drafting as required.

Let's explore the steps you would take to make an engineering drawing. In this example, we'll assume you are creating a corridor design.

1. Create a new drawing and add it to the project. Once a drawing has been added to your project, it will appear on the project tree in the Prospector tab of the Toolspace. For this example, we will store the corridor drawing in a folder called Engineering Plans as shown in Figure 17. Each project will contain collections of objects. For example, alignments will be in the alignment collection, surfaces in the surfaces collection, etc.
2. Data-reference the existing ground surface into the drawing by expanding the surfaces collection and creating a reference. This will import a reference of the surface from the project into your current drawing, allowing you to use the data for design work.
3. Apply styles and annotation as desired.
4. Repeat the process of data-referencing for the alignment and profile. When you finish, you will have the components needed to begin your corridor design.
5. Synchronize with the project, so that if any of the data references have been edited, the updates will be instantly reflected in your design. This allows you to keep your designs in sync across multiple users and multiple drawings.
6. After you create your design—in this case the corridor model and finished road grading—check it into a vault and share out the new surface.
7. Repeat this process for all other base, linework, and engineering drawings you create to complete Level 2 of the workflow.

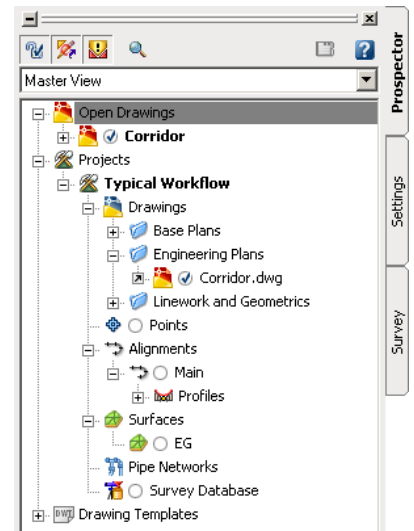

Figure 17. Project tree in the Prospector Toolspace showing a corridor drawing in the Engineering Plans folder.

Level 3: Creating Top-Level Production Sheets

After you have developed the relevant base, engineering, and linework drawings, you are ready to create a production sheet or a plan set drawing, such as a plan and profile, utility sheet, or landscaping sheet.

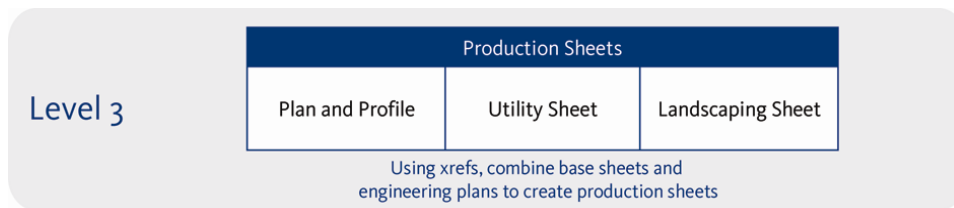

Figure 18. Level 3, create production sheets.

To generate these top-level (Level 3) sheets, you will xref your base, engineering, and linework plans together into a plan set drawing that can be used for generating layouts with title blocks and final drafting. Before you xref these drawings, you must make sure that you are accessing their latest versions. In AutoCAD Civil 3D, xrefs are accessed for project drawings (drawings that are part of the Autodesk Vault project) from your working folder. Therefore, you need to make sure that the latest versions of all drawings are in your working folder. To do this, find your project in the project tree on the Prospector tab of the Toolspace. Right click on the project's name to choose the command "Get Latest Version" (see Figure 19). This step pulls the most recent versions of all project drawings

and design objects into your working folder. Once you have the latest versions of all project drawings and objects, you can create your Level 3 production sheet.

Create the Plan Set Drawing

Let's assume you are working on a plan and profile sheet. First, you create a new drawing, name it, and save it to your working folder. Once it's saved, check it into a vault so that the drawing will be part of the project database. Make sure to choose the "Keep Checked Out" option so you can keep working on it. Use the XREF command to externally reference the appropriate Level 2 drawings, such as base linework, base utility, and base topology. When you create a top-level drawing in Level 3, the data you created in Level 2—including object data and label styles—are display-only. However, you can use Layer Manager to selectively hide and display layers within the Level 2 data. When you are done creating your xrefs, you can check the drawing into a vault while making sure to use the option "Include All File Dependencies." This allows all associated files to be copied to their working folders when other team members check out the plan set drawing. You will typically use a plan set drawing when using Sheet Set Manager (SSM) in AutoCAD Civil 3D. To create individual sheets in SSM, you create AutoCAD views within your plan set drawings. For more information on SSM, refer to the online AutoCAD Civil 3D Help system.

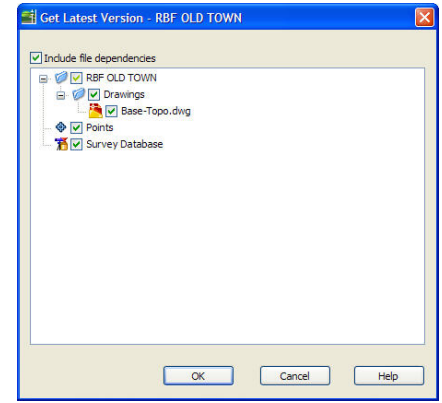

Figure 19. "Get Latest Version" dialog box.

Additional Drafting and Annotation

It is sometimes necessary to edit or add annotation to a design object during Level 3 of the workflow. To add annotation, just reference the appropriate design objects into your plan set drawing from the vault as data references, and apply the needed annotation or drafting. This gives you control over the stylization and annotation of the objects in the plan set drawings. Thus, you are able to take advantage of the work done in Level 1 and Level 2 of the workflow, while also allowing your drafters and technicians to finalize the annotation and Level 3 sheets needed to produce a full set of construction documents.

Addressing Interference

When drawings from Level 1 and Level 2 are externally referenced into Level 3, you may find that there are annotation interferences. If this happens, you can either use Layer Manager to turn off the unwanted text, or you can create a data reference of the design object in the Level 3 drawing and control its annotation there. Using this approach, the Level 3 drawings can be synchronized to reflect any changes that take place in lower levels. While creating references in Level 3 requires some duplicate work, it is negligible compared to the benefit of the top-level sheets being in sync with the design.

Working with Images

You may need to incorporate an image into your top-level production sheet. For example, a rough grading plan sheet may include aerial photographs. To add an image, create the drawing as recommended above (name it and save it to the working folder), attach the image (via xref Manager or by using AutoCAD® Raster Design software), and then check the drawing into a vault, making sure to choose the "Keep All File Dependencies" option. By choosing this option, you maintain the link between the drawing and the image. After completing this process, the drawing and attached image will be saved in the vault.

Bypassing Level 2

You may be able to complete some projects without going through all levels of the workflow. In particular, you may not need to create any intermediate drawings in Level 2. Instead, you may be able to create top-level sheets by directly data referencing individual

object drawings created in Level 1. The benefit of bypassing Level 2 drawings is that you can do labeling directly in the Level 3 drawings, avoiding the possibility of interference. The downside of bypassing Level 2 is that you remove the option of combining objects from Level 1 to engineer or design elements—such as corridors or utilities—on design data.

Conclusion

By adopting a workflow like the one outlined in this paper, you enable your teams to work securely and collaboratively—so they can finish civil engineering projects faster. When you use Autodesk Vault to manage project data, you extend the dynamic object updates that occur within a single AutoCAD Civil 3D drawing across multiple drawings. Using the powerful Civil 3D design tools to create your designs along with Vault to facilitate collaboration and easy, controlled access to project files, you minimize manual work, reduce errors, and complete plans more quickly and easily.

To learn more about how you can use Autodesk Vault with AutoCAD Civil 3D to facilitate your civil engineering projects, visit <http://www.autodesk.com/VaultForCivil3D>.

Autodesk, AutoCAD, Civil 3D, DWF, and DWG are registered trademarks or trademarks of Autodesk, Inc., in the USA and/or other countries. All other brand names, product names, or trademarks belong to their respective holders. Autodesk reserves the right to alter product offerings and specifications at any time without notice, and is not responsible for typographical or graphical errors that may appear in this document.

© 2007 Autodesk, Inc. All rights reserved.