

Autodesk 3ds Max

Student Workbook

Working with Revit Architecture Designs in Autodesk 3ds Max

Contents

Introduction	3
Unit 1: Data Transfer	5
1.1 Exporting from Revit Architecture in DWG Format	5
1.2 Setting 3ds Max Default UI	6
1.3 Setting 3ds Max Display Units	7
1.4 Linking a DWG File	9
1.5 Binding a DWG File	11
Unit 2: UI Overview	12
2.1 Using the Layer Manager	12
2.2 Using the Select By Name Dialog	15
2.3 Adjusting Viewport Sizes	16
2.4 Using Zoom, Pan and Arc Rotate	17
2.5 Changing Views	18
Unit 3: Additional Modeling	20
3.1 Creating a Rock	20
3.2 Applying a Noise Modifier	22
3.3 Scaling the Geometry	23
3.4 Applying a Material to the Rock	24
3.5 Applying Paint Deformation	24
3.6 Merging a 3ds Max File	26
3.7 Cloning the Rock	27
3.8 Adding Foliage	29
Unit 4: Materials	32
4.1 Determining the Material Type	32
4.2 Setting Real-World Map Scale	33
4.3 Replacing Revit Architecture Procedural Maps	36
4.4 Applying a mental ray Arch & Design (mi) Material	38
Unit 5: Lighting	40
5.1 Creating a Daylight System	40
5.2 Animating Time of Day	42
5.3 Creating Interior Omni Lights	45
5.4 Animating the Omni Lights	49
Unit 6: Rendering	50
6.1 Creating and Positioning a Camera	50
6.2 Using Camera Viewport Controls	52
6.3 Animating the Camera	53
6.4 Using the Render Dialog Box	55
6.5 Setting Final Gather	56
6.6 Saving a Rendered Image from the Framebuffer Window	58
6.7 Saving Directly from the Render Dialog Box	59
6.8 Rendering an Animation	60

Introduction

This student workbook contains a set of exercises that clarify in a practical way the concepts behind rendering an architectural model in 3ds Max.

The exercises cover the basic workflow of transferring architectural designs from Revit Architecture into 3ds Max with the goal of adding organic modeling, animating and rendering the project. For more training information, see the official 3ds Max training manuals and the tutorials available from the help menu. This workbook explains the different functionalities through various exercises, but the emphasis is on the workflow rather than on the tools themselves.

The difficulty of the exercises increases as you proceed through the units, so it is recommended that you do them in sequence. Most units are independent and can be done starting with the provided files. Files with the completed exercises are included in the data set folder and can be used to check your work.

The workbook is structured in a three-column format (see image below):

- The first column contains an explanation of all steps necessary to complete an exercise.
- The middle column contains the images that clarify visually the tasks to accomplish.
- The third column contains notes on the features and tools that are being used and a few helpful tips.

Practical Instructions to Complete the Exercises

1. Press **F10** to open the **Render** dialog box.
2. Under **Time Output**, click **Active Time Segment**.
3. To speed up the process, set **Every Nth Frame** to **10**.
4. Under **Output Size**, click **320x240**.

Images

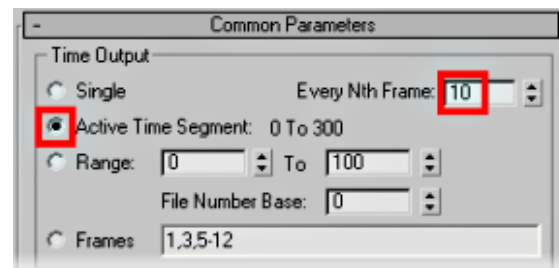

Notes on the Features and on the Software in General

Setting **Every Nth Frame** to **10** causes 3ds Max to render every tenth frame. Doing so accelerates rendering and is useful for early evaluation of an animation.

We have prepared the following data for you:

- Workbook (this document)
- Workbook data sets (placed in a folder that contains all necessary files and images prepared for your use)

Before starting the exercises, change the following settings to simplify use of this workbook and provide faster access to the data sets:

1. Verify that both **Revit Architecture** and **3ds Max** are installed on your system. When **3ds Max** is installed, the default working directory is **My Documents\3dsmax\scenes**.

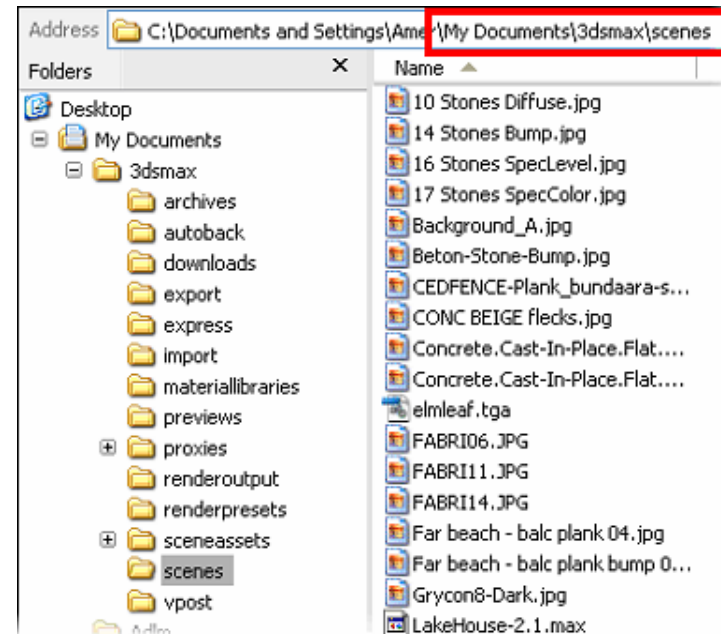

2. **Copy** the provided **Workbook Data Sets** folder contents onto the **3ds Max** working folder as shown at right.

We hope you enjoy learning the principles of using 3ds Max for design and visualization.

Have fun!

Unit 1: Data Transfer

1.1 Exporting from Revit Architecture in DWG Format

1. Start **Revit Architecture**.
2. Open **LakeHouse-i.rvt**.
3. On the toolbar, click the default **3D View** button.
4. Click **File** menu > **Export** > **CAD Formats**.
5. In the Export dialog box, enter the file name as **LakeHouse-i.dwg**.
6. Under **Export Range**, verify that **Current View** is selected.
7. Click **Options**.
8. Under **Solids**, verify that **Export as Polymesh** is selected.

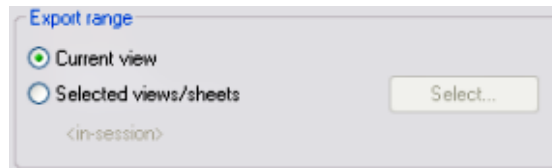
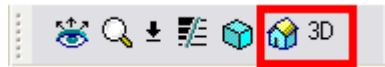

By default, Revit Architecture exports the current view. Setting it to a 3D view causes 3D geometry to be exported.

The Revit Architecture export to DWG™ defaults to the AutoCAD® 2007 format, which works well with 3ds Max.

Polymesh breaks the objects into separate surfaces. It makes it easy to assign different materials to different components such as the inside and outside surfaces of a wall. The **ACIS**® option treats objects as solids (with volume). It makes material management slightly more complex, but you get the added advantage of being able to use Boolean operations to add, subtract, or intersect 3D

9. Click **OK**.
10. Click **Save**.
11. Close **Revit Architecture**.

objects together.

1.2 Setting 3ds Max Default UI

1. Open **3ds Max**.
2. Click **Customize** menu > **Custom UI and Defaults Switcher**.
3. Under **Initial Settings for Tool Options**, click **DesignVIZ.mentalray**.
4. Click **Set** to implement the changes.
5. Click **OK** to close the warning dialog box.

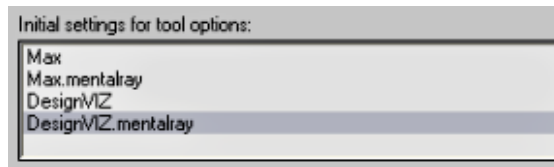
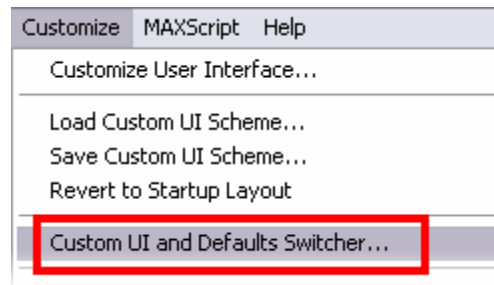

The **DesignVIZ.mentalray** configuration provides initial tool settings that are suitable for rendering architectural models with the mental ray[®] rendering engine.

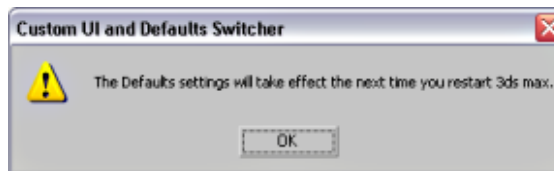

The DesignVIZ.mentalray configuration remains in effect even after you shut down 3ds Max.

6. Close, and then reopen **3ds Max**.

1.3 Setting 3ds Max Display Units

1. Click **Customize** menu > **Units Setup**.

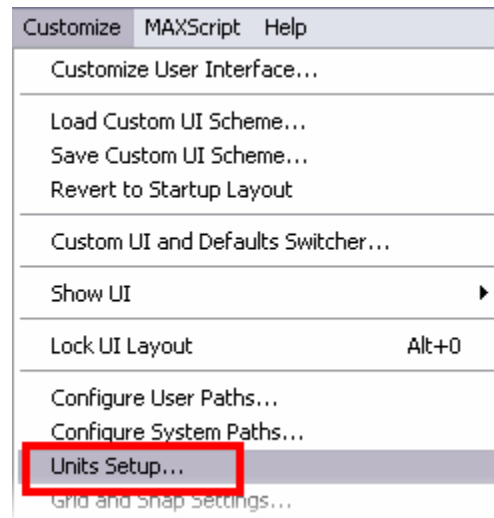

2. Under **Display Unit Scale**, click **US Standard**.

3. Select **Feet w/Fractional Inches** from the units list.

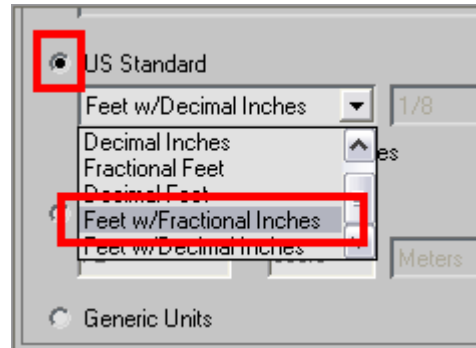

4. Click **OK** to close the **Units Setup** dialog box.

The **Display Units** setup in 3ds Max controls how values are presented in the user interface.

1.4 Linking a DWG File

1. Click **File** menu > **File Link Manager**.

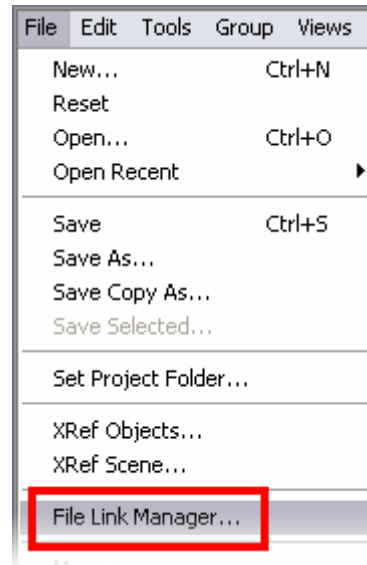

2. Click **File** and then select the **LakeHouse-i.dwg** file you saved earlier.
3. Select **Revit** from the Preset list.
4. Select the **Rescale** check box.

For your convenience, a version of this file has been provided as part of this data set.

The Revit preset has options configured especially for linking DWG files exported from Revit Architecture.

5. Verify that Incoming File Units is set to **Inches**.

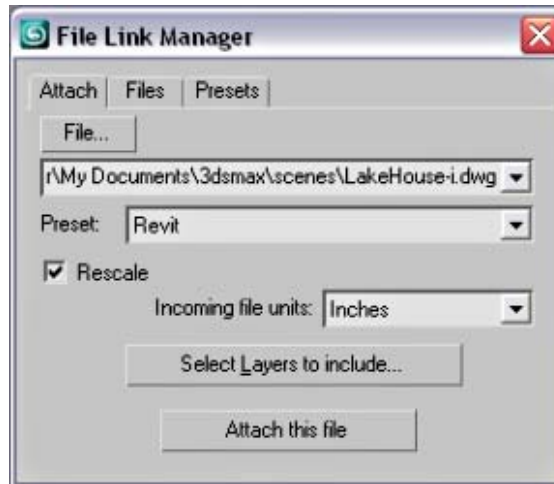

6. Click **Attach This File**. The linked drawing file appears in the viewports.



7. Close the **File Link Manager** dialog box.

Linking in this manner enables 3ds Max data to be updated when a change occurs in the source DWG file.

1.5 Binding a DWG File

1. Click **File** menu > **File Link Manager**.
2. Click the **Files** tab.
3. Click **Bind**. A warning dialog indicates that the link to the source drawing file is about to be broken.
4. Click **Proceed with Bind**.
5. Close the **File Link Manager** dialog box.
6. Save the file as **myLakehouse.max**.

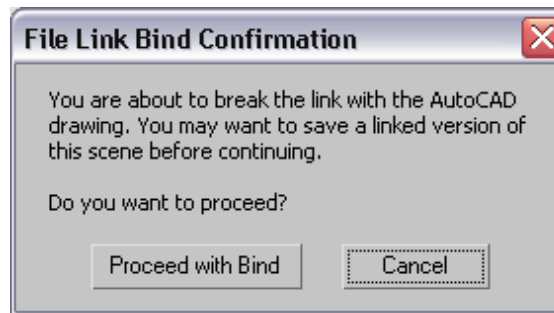

LakeHouse-i.dwg appears in the Linked Files list.

The link to the source **LakeHouse-i.dwg** file is now broken. Any changes made to the **DWG** file are not reflected in **3ds Max**.

Note that binding a file should be done only when you're certain no further changes will be made in **Revit Architecture**.

Unit 2: UI Overview

2.1 Using the Layer Manager

1. Open **LakeHouse-2.1.max**.

2. Right-click an empty area of the main toolbar. Click **Layers**.

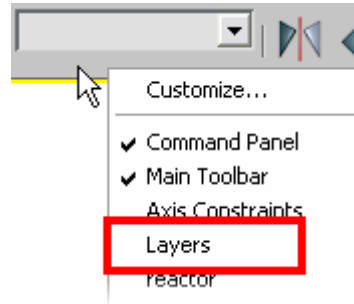

3. On the **Layers** toolbar, click the Layers list.

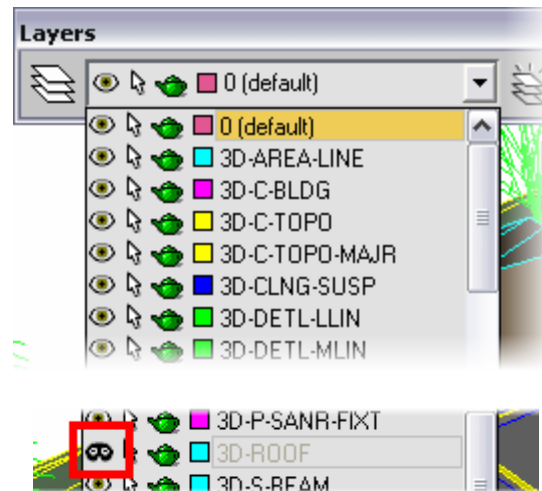

4. Click the eye icon adjacent to the **3D-ROOF** layer. This makes the layer

If you get a warning when opening a file in 3ds Max, always click **Adopt the File's Unit Scale**.

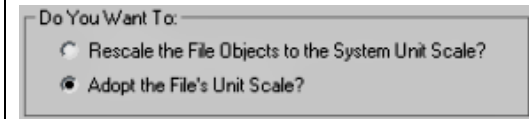

Note the layers that were imported from the DWG file.

invisible in the viewport.

- 5. On the main toolbar, click the selection tool. Use this tool to select any of the 3D trees in the viewport.



- 6. On the Layers toolbar, click the **Set Current Layer to Selection's Layer** icon. This makes the layer containing the selected object current.

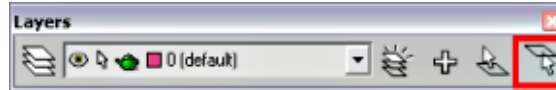

- 7. Hide the **3D-L-PLNT-BEDS** layer as you did the roof layer earlier. The trees disappear from the viewport.

- 8. On the **Layers** toolbar, click the **Layer Manager** icon to open the dialog box.



- 9. Select the **3D-CLNG-SUSP** layer and then click the **Select Highlighted Objects and Layers** icon. All objects belonging to this layer are now selected in the viewport.

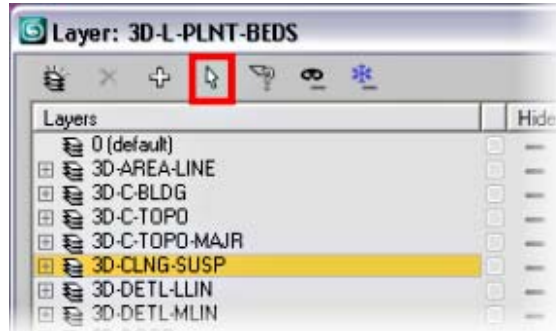

- 10. On the main toolbar, select the **Move** tool.



Using this tool is a quick way to find out which object belongs to which layer.

The **Layer Manager** offers more flexibility than you can achieve when using only the Layers list.

11. Move the cursor over the **Z** axis of the transform gizmo, and then click and drag to raise the ceiling.

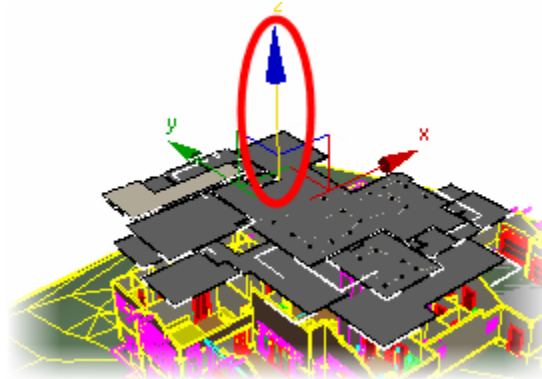

12. On the main toolbar, click the **Undo** tool to return the ceiling to its original position.



13. Hide the ceilings layer by clicking the eye icon in the **Hide** column.

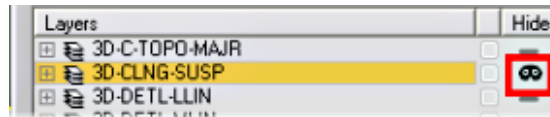

14. Click the plus (+) sign next to the **3D-EQPM** layer to expand its hierarchy. You can now view all objects that belong to this layer.

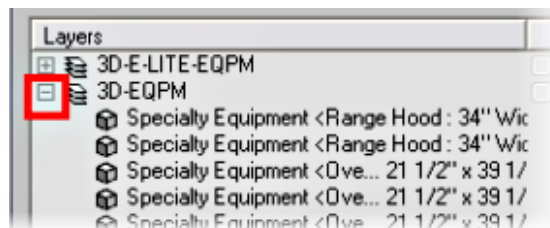

15. With the **3D-EQPM** layer, highlight the first object: **Specialty Equipment <Entrance Beam : Entrance Beam>**.

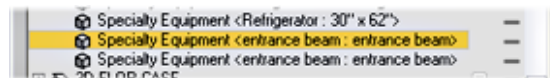

16. Select this object in the scene using the **Select Highlighted Objects and Layers** icon. The object is now

This is the same as hiding a layer from the Layers list. In addition to hiding, you can also freeze a layer to prevent objects on the layer from being selected or modified. Frozen objects do, however, appear in the viewport shaded in gray.

The **Select Highlighted Objects and Layers** icon works equally well to select all objects on a

selected in the viewport and ready for editing.

17. Close the Layer Manager.

layer or individual objects that are part of a layer.

2.2 Using the Select By Name Dialog

1. Continue with the existing file.
2. On the main toolbar, click the **Select by Name** icon.
3. At the bottom of the dialog box, select the **Display Subtree** check box.
4. Select the nonindented object (parent) named **Doors <GARAGE DOOR 1-8_and_7-Foot-High : 10'-0" x 8'-0">**.

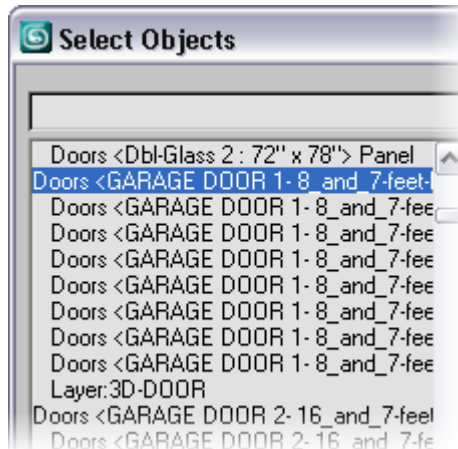
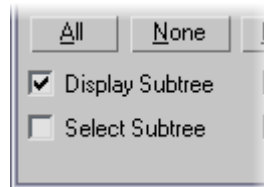
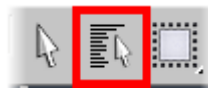

An object indented in the list is linked to a parent object above it.

The translated names of the linked parts are difficult to distinguish because many of the names are duplicated. The **Layer Manager** may be an easier way to select geometry. However, the **Select by Name** dialog box is an important part of 3ds Max. You have the chance to use it again in subsequent exercises.

5. Click **Select** to select all the components that make the garage door. The garage door is now selected and ready for editing in the viewport.

2.3 Adjusting Viewport Sizes

1. Open **Lakehouse-2.3.max**.
2. In the bottom-right corner of the screen, click the **Maximize Viewport Toggle** icon.
3. Position your cursor at the intersection of the four viewports, and then click and drag upward and to the left.
4. Once again, position your cursor at the viewport intersection, but this time, right-click and then click **Reset Layout**.
5. Right-click in any viewport to make it active.
6. Right-click in the **Perspective** viewport.

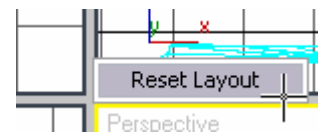
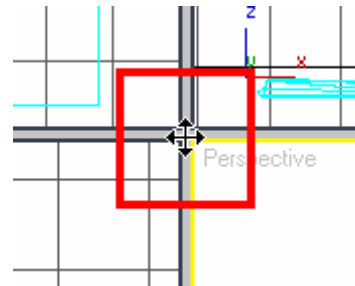
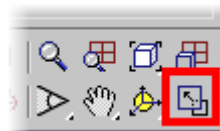

The single viewport becomes four individual viewports.

Reset Layout restores the viewports to their original sizes.

The active viewport is highlighted with a yellow border.

Note that left-clicking also changes which viewport is active, but it has the added effect of

7. Press **ALT+W** to toggle the **Perspective** viewport to full screen.

removing an object from selection.

ALT+W has the same effect as the **Maximize Viewport** toggle.

2.4 Using Zoom, Pan and Arc Rotate

1. Continue with your existing file.
2. Click the **Zoom** tool at the lower-right of the screen.

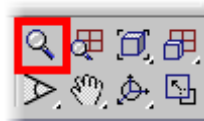

3. Click and drag upward in the viewport to zoom in on the model.
4. Click the **Pan View** tool.

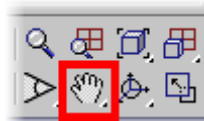

5. Click and drag to the left in the viewport.
6. Click **Zoom Extents** to frame all of the scene geometry in the viewport.



7. Click **Arc Rotate**.

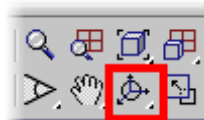

If you're using a wheel mouse, zoom by rolling the wheel, and pan by pressing and dragging it.

Undo a view change by pressing **SHIFT+Z**.

8. Click and drag inside the yellow circle to orbit around the scene.

The viewpoint is rotated about the view center.

2.5 Changing Views

1. Open **LakeHouse-2.5.max**.
2. Click **Views** menu > **Save Active Perspective View**.

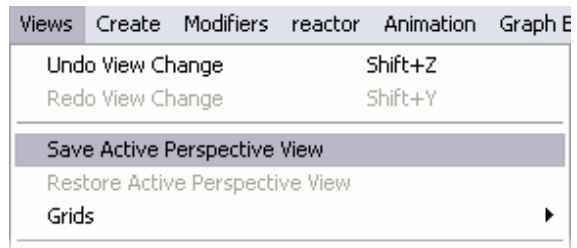

This saves the view so it can be recalled at a later time.

3. Press **T** to switch to the top viewport.
4. Press **G** to toggle the grid.
5. Press **L** to switch to the Left view.
6. Press **F** to set the Front view.
7. Press **P** to switch back to the perspective view.
8. Use **Arc Rotate** to change the perspective view a small amount.

- Click **Views** menu > **Restore Active Perspective View**.

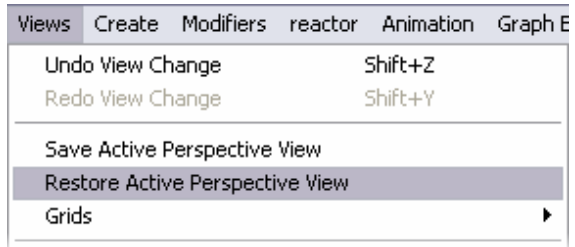

- Right-click the **Perspective** viewport label. Click **Views**.

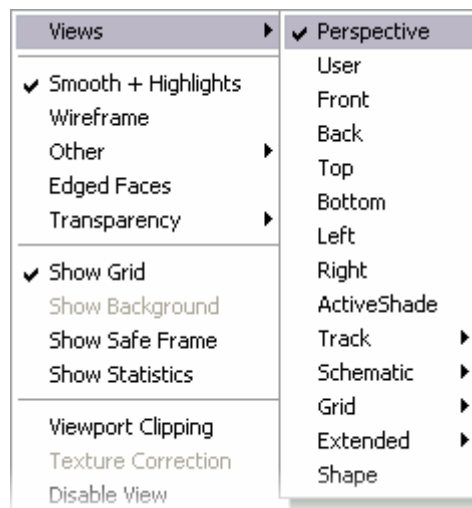

- Press **F3** to switch to toggle **Wireframe** mode.
- Press **F3** again to toggle **Shaded** mode.
- In Shaded mode, press **F4** to toggle **Edged Faces** mode.

The Viewport Label menu is accessible in the top-left corner of the viewport.

Note that all the views are accessible from the Viewport Label menu.

Several views have shortcuts. For example, Top, Left, and Front are set already. Views that do not have a keyboard shortcut can be accessed via the Viewport Label menu.

Edged Faces is useful because it shows the models shaded and enables you to see the underlying topology. This mode is ideal when modeling in **3ds Max**.

Wireframe, Shaded (**Smooth & Highlight**), and **Edged Faces** modes are also available by

right-clicking the viewport label.

Unit 3: Additional Modeling

3.1 Creating a Rock

1. Start or reset **3ds Max**.
2. Click **Customize** menu > **Units Setup**. Verify that **Display Unit Scale** is set to **US Standard** > **Decimal Inches**.
3. On the **Create** panel, under **Geometry**, click **GeoSphere**.
4. Click and drag in the Perspective viewport to create the geosphere.
5. Press **F4** to turn on **Edged Faces**

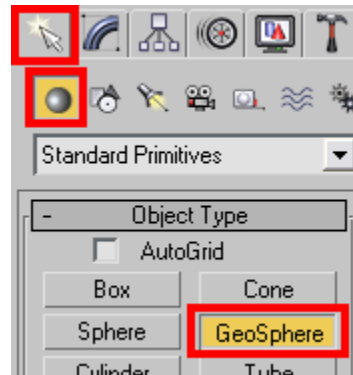

The **Command** panels are to the right of the screen. The first panel (**Create**) and the second panel (**Modify**) are the two you use most often.

Edged Faces mode illustrates the faces

mode.

- 6. With the geosphere selected, go to the **Modify** panel.

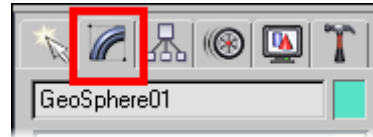

- 7. Set **Radius** to **8.0"**, set **Segments** to **10**, and clear the **Real-World Map Size** check box.

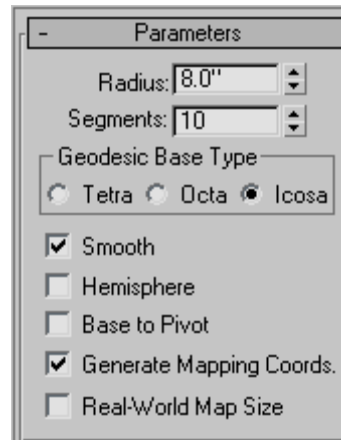

making up the object.

Increasing the number of segments adds detail to the geosphere.

3.2 Applying a Noise Modifier

1. With the geosphere selected, select **Modifier List**.

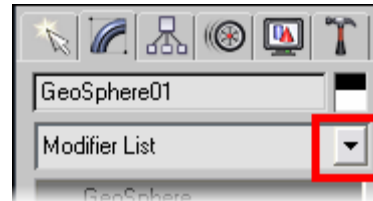

2. Select **Noise** from the list.

The **Noise** modifier appears above the geosphere in the modifier list.

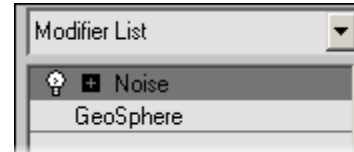

3. Under **Parameters, Noise**, select the **Fractal** check box.

4. Set the noise **Strength** parameters to **X: 6.0"**, **Y: 12.0"**, and **Z: 3.0"**.

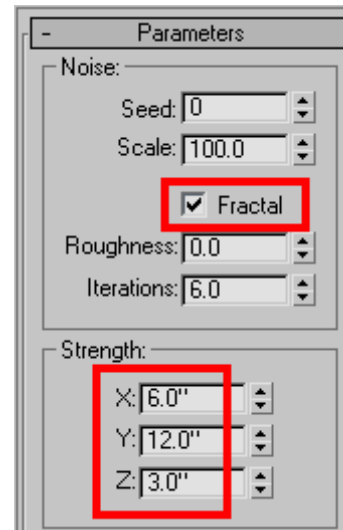

The **Noise** modifier enables you to add random distortion to an object.

Modifiers are listed alphabetically.

Selecting **Fractal** adds chaos to the noise distortion.

5. Enter **Rock01** as the new name for the geosphere in the **Name and Color** field.

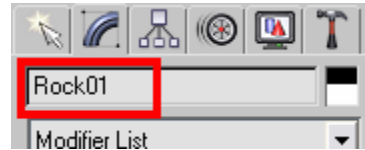

3.3 Scaling the Geometry

1. On the main toolbar, **Scale** flyout, click **Select and Squash**.

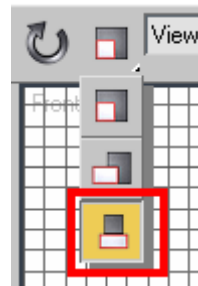

2. Position the cursor over the **Z** axis of the transform gizmo, and drag it downward until it looks approximately as shown.

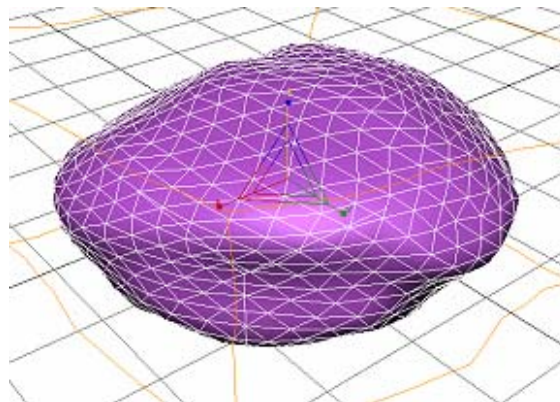

Use the **Scale and Squash** tool to scale an object down in one direction while scaling up in the other directions, maintaining its volume.

3.4 Applying a Material to the Rock

1. Open **LakeHouse-3.4.max**.
2. Press **M** to open the **Material Editor**.
3. Click and drag the first sample sphere over the rock in the scene and release.

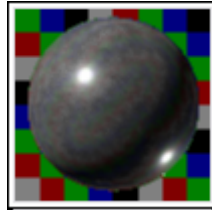

4. Close the **Material Editor**.

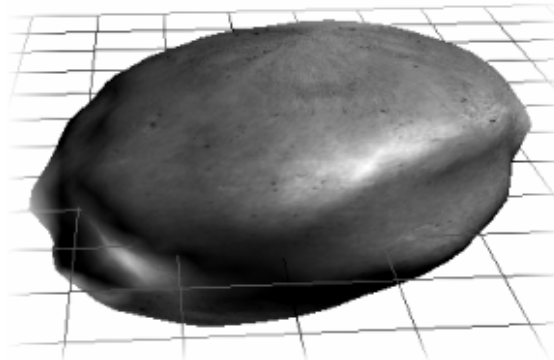

The material appears on the rock in the viewport.

5. Click **File** menu > **Save As**.
6. Name the file **Rock.max**.

3.5 Applying Paint Deformation

1. Open **LakeHouse-3.5.max**.

- Using the **Select Object** tool, select the terrain by clicking it in the viewport.



- Press **F4** to turn on **Edged Faces** mode.
- Go to the **Modify** panel.
- Scroll to the bottom of the panel and expand the **Paint Deformation** rollout.
- Set **Push/Pull Value** to **1'6"**.
- Set **Brush Size** to **12'0"**.
- Click **Push/Pull**.

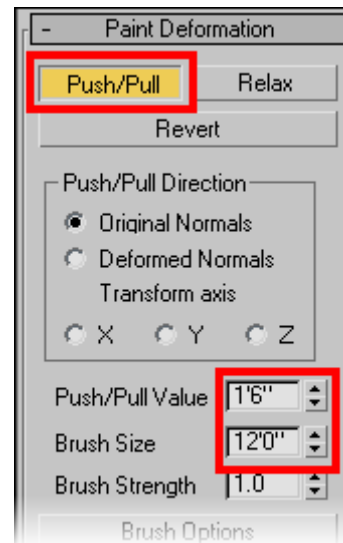

9. Click and drag in the viewport near the waterline.

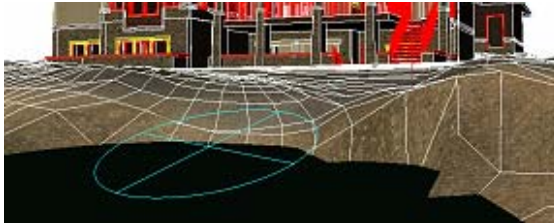

The geometry is displaced as you move the mouse over the indicated region. Holding **ALT** while clicking and dragging reverses the displacement.

10. Click the **Relax** tool.

The **Relax** tool spreads out adjacent vertices (points) that are too close together and brings closer together adjacent vertices that are too far apart.

11. Click and drag areas of the terrain to smooth the work you did using the **Push/Pull** tool.
12. Click **Relax** again to end the operation.

3.6 Merging a 3ds Max File

1. Open **Lakehouse-3.6.max**.
2. Click **File** menu > **Merge**.
3. Select the file named **Rock.max**.
4. Click **Open**.
5. In the **Merge by Name** dialog box, highlight **Rock01** and click **OK**. The rock is now part of the current scene and selected.

Merging enables you to add the contents of one 3ds Max file into another.

The rock is invisible for the moment because it lies behind the terrain.

6. On the main toolbar, click **Move**.
7. At the bottom of the screen, type in the coordinates: **X:-82'0"**, **Y:-3'6"**, **Z: -3'6"**.

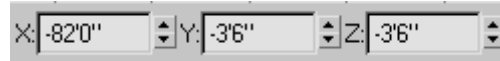

3.7 Cloning the Rock

1. Continue from the previous exercise.
2. Select the rock if it isn't selected already.
3. Verify that the **Move** tool is selected.
4. Press and hold **SHIFT**.
5. Position the cursor over the **Y** axis of the transform gizmo, and drag a short distance to the left.

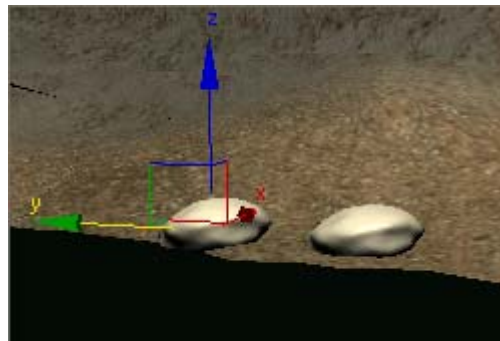

- Under Object, click **Copy**, and set Number of Copies to **3**.

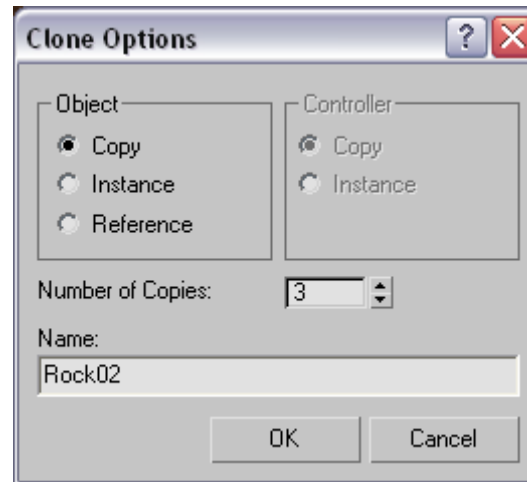

Choosing **Copy** enables you to make changes to the cloned objects without affecting the original.

3ds Max gives each copy a unique sequentially applied name: Rock02, Rock03, and so forth.

- Click **OK**.
- Select **Rock02** (the first copy to the left of the original rock).
- Go to the **Modify** Panel.
- Change **Seed** to **1**.

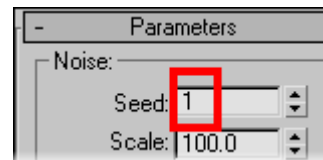

- Set the Seed value of **Rock03** to **2**, and **Rock04** to **3**.



The Seed value is a starting value for the random noise. Changing the Seed value makes each rock unique. Without the ability to change the Seed value, all objects would be identical (assuming other noise parameters were the same).

Experiment with other seed numbers to get the rock shapes you like.

12. On the main toolbar, click the **Scale** tool.
13. Select each of the rocks and scale them to different amounts to make them look more natural. Use **Move** and **Rotate** to position and orient the rocks randomly in the scene.



3.8 Adding Foliage

1. Open **Lakehouse-3.8.max**.
2. On the **Create** panel, select the **AEC Extended** geometry type.
3. Click **Foliage**.
4. Choose the **American Elm** tree type.

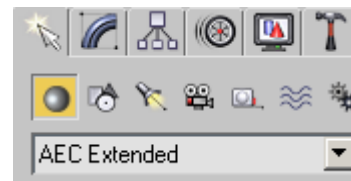

5. In the top view, click a point near the house to create a tree.

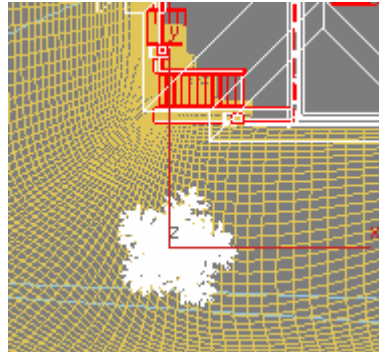

6. Right-click to end foliage creation.
7. Using the **Move** tool, adjust the tree's **Z**-position in the camera view so that the trunk isn't sunk in the ground.
8. Go to the **Modify** Panel.
9. Set **Height** to **21'0"** and **Density** to **0.6**.

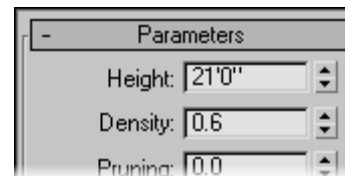

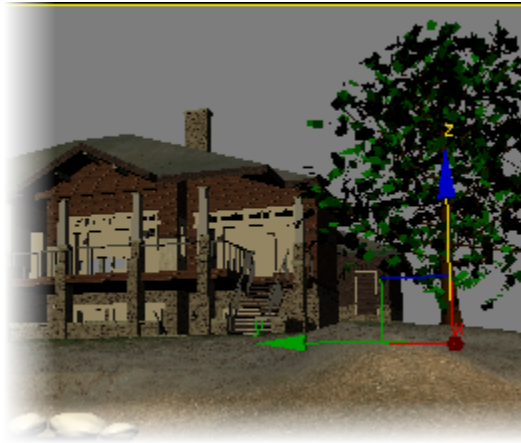

Unit 4: Materials

4.1 Determining the Material Type

1. Open the file **Lakehouse 4.1.max**.
2. On the main toolbar, click the **Select Object** tool.
3. Click the roof in the viewport to select it.
4. Right-click over the roof. Click **Quad** menu > **Object Properties**.

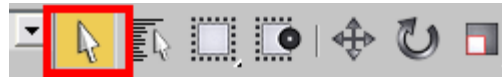

5. Notice the roof's material shown in the **Object Properties** dialog box.

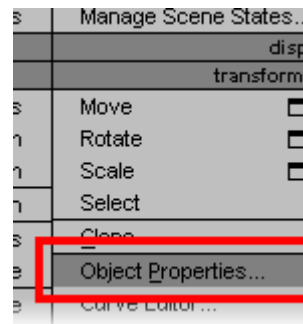

6. Click **OK** to close the **Object Properties** dialog box.
7. Press **M** to open the Material Editor.

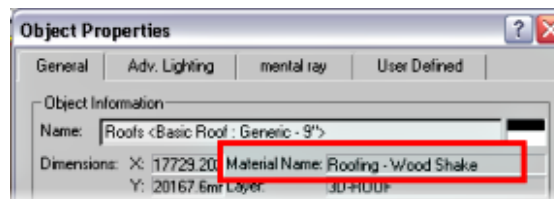

The **Object Properties** dialog box shows the applied material along with many other object characteristics.

8. Verify that the top-left sample slot is active.
9. Click the **Pick Material from Object** icon.
10. Click the roof.

The roof's material is loaded in the sample slot.

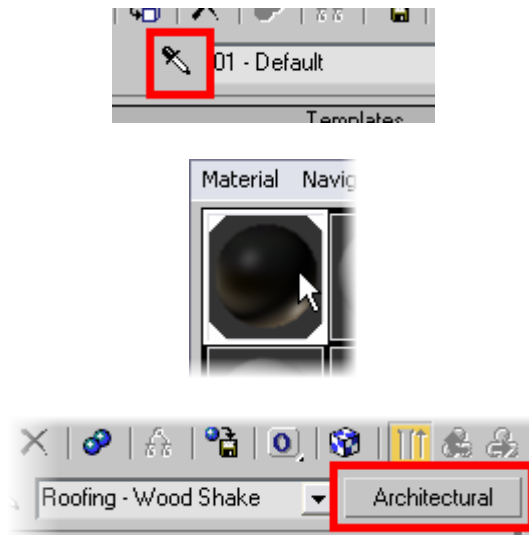

Note that the material type is **Architectural**.

4.2 Setting Real-World Map Scale

1. Click the **Show Map in Viewport** icon. The shingles map is now visible in the viewport.
2. Click the **Diffuse Map** button named **Shake Texture (SHAKE2.JPG)**.

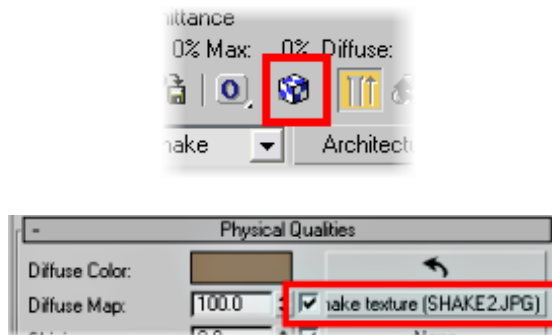

Revit materials that are based on bitmaps transfer properly into 3ds Max, maintaining the correct scale. You can, however, edit the scale to better suit your needs.

The **Diffuse Color** represents the color of a surface under direct lighting. A diffuse map replaces that color with a map, such as a scanned image (bitmap).

3. In the Bitmap Parameters rollout, click **View Image**.

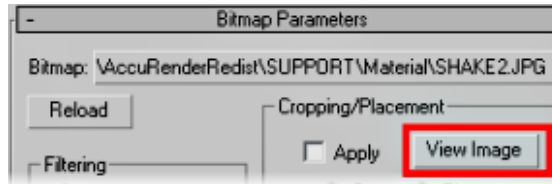

The bitmap appears in a window. It shows shingles spread out roughly 4'-6" across by 1'-6" high.

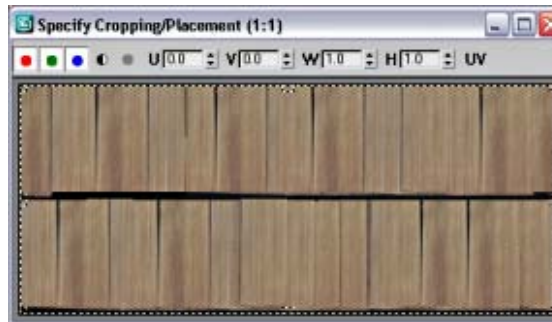

4. Close the **View Image** window.
5. In the **Coordinates** rollout, select the **Use Real-World Scale** check box.



6. Enter 4'6" and 1'6" in the **Width** and **Height** fields, respectively.

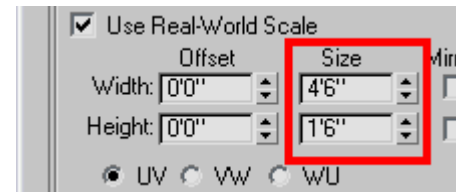

To correctly apply this map to the roof, the dimensions of the image must be known, or closely approximated. This is based on knowledge of the physical size of the objects shown in the bitmap. For this exercise assume it is 4'-6" wide and 1'-6" high.

7. Close the **Material Editor**. The map appears at the correct scale in the scene. However, it isn't wrapping properly.

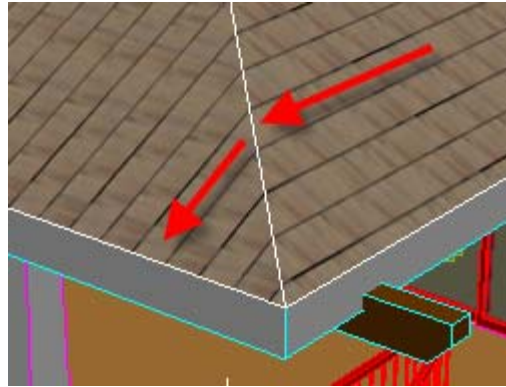

8. Verify that the roof is still selected.
9. Go to the **Modify** panel.
10. From the **Modifier List** select **Map Scaler OSM** (Object-Space Modifier).

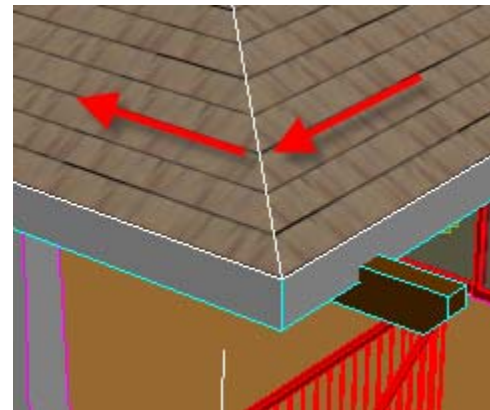
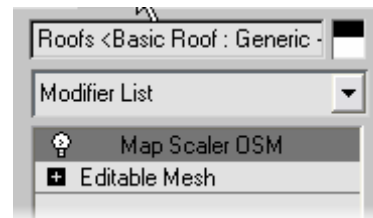

With the **Map Scaler** modifier applied, the shingles wrap around the roof correctly.

4.3 Replacing Revit Architecture Procedural Maps

1. Zoom in on the columns below the porch.
2. Press **M** to open the **Material Editor**.
3. Choose the second sample slot.
4. Using the **Pick Material from Object** tool as earlier, click one of the columns to sample its material.

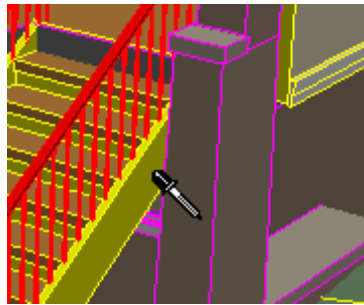

5. Note that the material coming from **Revit Architecture** also translates as an **Architectural** material type. However, it has a procedural map assigned in **Revit Architecture** that does not carry over to **3ds Max** after file linking.

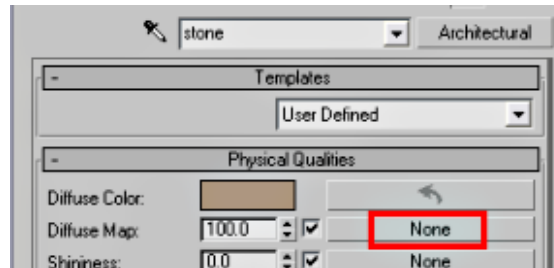

6. Click **None** next to **Diffuse Map**.
7. In the **Material/Map Browser**, double-click **Bitmap**.

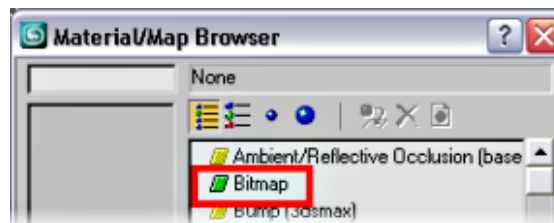

Procedural maps are based on mathematical algorithms. They avoid the need for a fixed bitmap file and have the advantage of being adjusted to suit the application. 3ds Max supports procedural maps. However, those applied within Revit Architecture are not brought in with file linking. In that case, only the diffuse color is taken into account.

8. In the **\Scenes** working folder, select the file named **Beton-Stone-Bump.jpg**.
9. Enable **Show Map in Viewport** and set the sizes to **W:6'0"** and **H:3'6"**. The concrete map appears, properly scaled in the viewport.

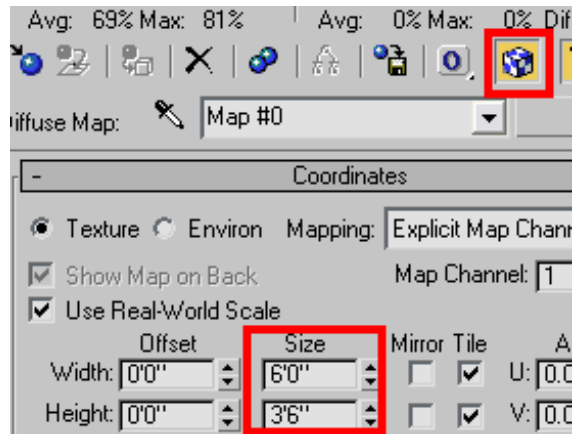

10. Close the **Material Editor**.

4.4 Applying a mental ray Arch & Design (mi) Material

1. In the **Material Editor**, click the **Go to Parent** icon to go back to the top of the material definition.



2. Click the **Architectural** material type.

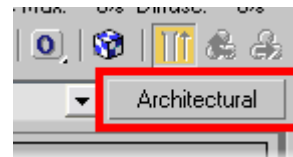

3. In the **Material/Map Browser**, double-click **Arch & Design (mi)**.

4. From the Templates list, select **Rough Concrete**.

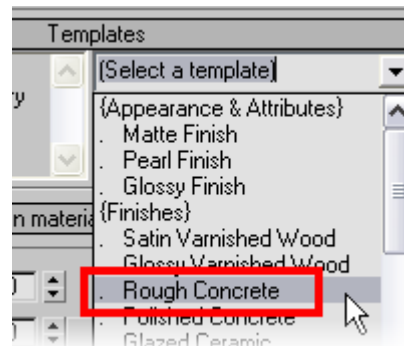

The **Arch & Design** material is a **mental ray**-specific material designed to support most materials used in architectural and product-design renderings. It is based on templates and therefore easy to set up. It supports most hard-surface materials such as metal, wood, and glass. It also works well with fast, glossy reflections and refractions and high-quality glass.

5. In the **Main Material Parameters** rollout, click the **M** (Map) next to the **Color** swatch.

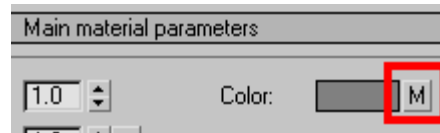

6. In the **RGB Multiply Parameters** rollout, click the button next to the **Color #1** swatch. It represents the concrete bitmap.

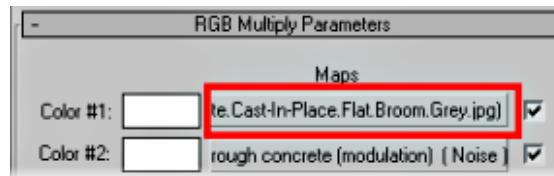

7. Enable **Show Map in Viewport**. The map scale needs to be adjusted before it displays properly.

8. Select the **Use Real-World Scale** check box, and set the width and height sizes to **6'0"**. The bitmap now appears on the columns scaled correctly.

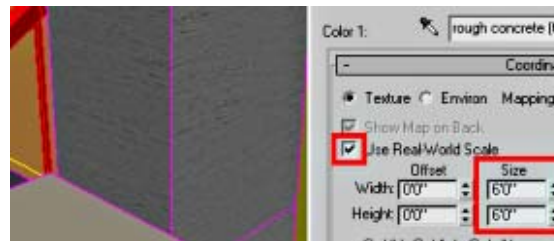

Unit 5: Lighting

5.1 Creating a Daylight System

1. Open **Lakehouse 5.1max**.
2. From the **Create** panel, select the **Systems** category.

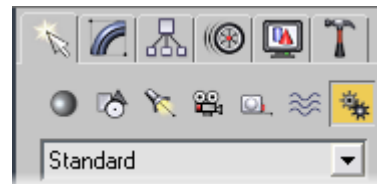

3. Click **Daylight**.
4. Click and drag anywhere in the top viewport to define the compass.
5. In the **mental ray Sky** dialog box, click **Yes**.

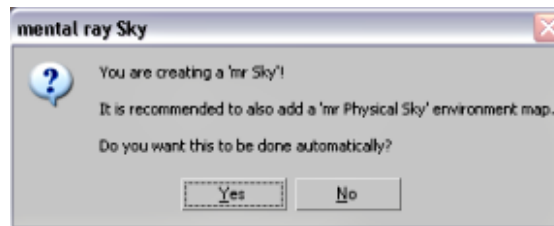

6. Drag the cursor sideways to extend the **Orbital Scale**.

Compass size is set for convenience only. It does not change the effect of the light.

This dialog box appears if the defaults switcher is set to **DesignVIZ.mental ray** and there isn't an existing map assigned to the render environment.

Use **Orbital Scale** to position the daylight head away from scene geometry. The position doesn't affect rendered output.

7. In the command panel, click **Get Location**.

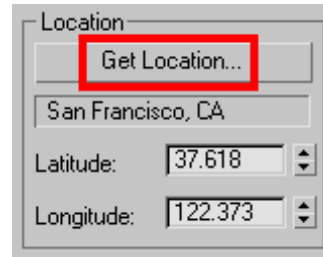

8. Select **Denver CO** in the list.

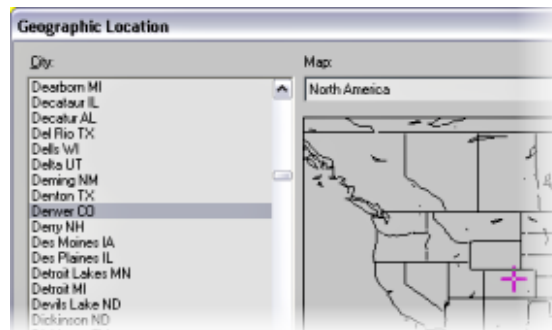

9. Click **OK** to close the **Geographic Location** dialog box.
10. Right-click in the current viewport to cancel the daylight system creation.
11. Click **Rendering** menu > **Environment**.

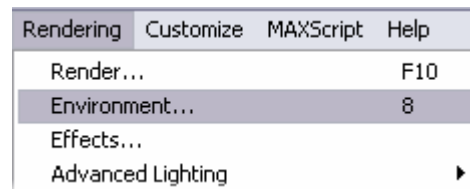

The daylight system shows up as an assembly, rather than a light.

The Date, Time, and Location controls for the daylight system appear in the **Motion** panel. The light parameters appear in the **Modify** panel.

- Note that the **mr Physical Sky** environment map appears under **Background**.

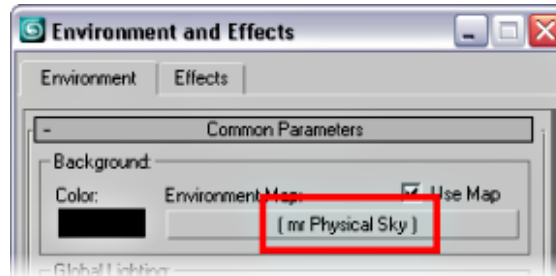

- Under **Logarithmic Exposure Control Parameters**, click the **Exterior Daylight** check box.

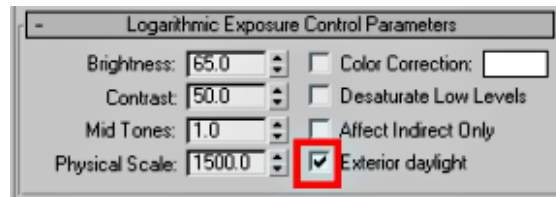

Enabling **Exterior Daylight** adjusts exposure to account for the sun's high energy level.



Ext. daylight off.

Ext. daylight on.

5.2 Animating Time of Day

- Open **LakeHouse-5.2.max**.
- In the **Perspective** view, select the daylight system (**Daylight01**).
- Go to the **Motion** panel.



- In the **Control Parameters** rollout, set the time to **8:00** and the day to **June 1**.

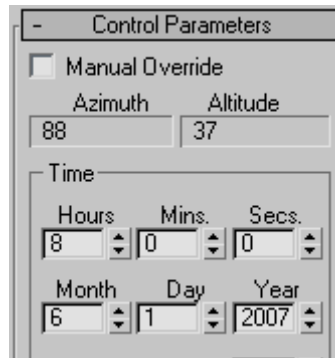

- In the bottom-right corner of the screen, click the **Time Configuration** icon.

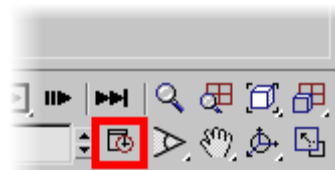

- Set **End Time** to **300**.

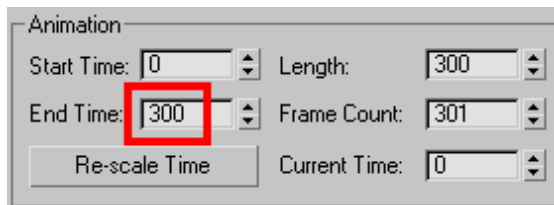

- Click **OK** to close the **Time Configuration** dialog box.
- Drag the time slider to frame **300**
- Enable **Auto Key** animation mode.

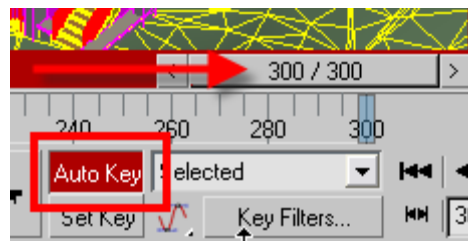

Setting the animation End Time to 300 frames results in 10 seconds of animation based on the NTSC standard of 30 frames per second.

Auto Key causes an animation key to be created when time parameters are changed.

10. Set Time to **8:00 p.m.** (20 hours on the 24-hour clock).

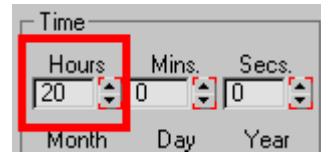

11. Turn off **Auto Key**.

12. Click the **Play Animation** icon to view the daylight head move across the scene.



13. Click the **Go to Start** icon to return the time slider to frame 0.

14. Verify **Daylight01** is still selected.

15. On the main toolbar, click the **Curve Editor** icon.

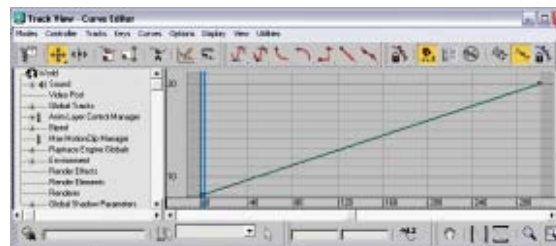

16. Close the **Curve Editor**.

The effects of the daylight system at various times of day can be seen when you render the animation, but first, you need to adjust some additional values.

You can also “scrub” the animation slider bar to go to a particular frame of the animation.

The **Curve Editor** shows a graphical display of the animated time. The value of the animated characteristic is shown on the vertical axis (in this case, 8 a.m. to 8 p.m.), while time in frames is displayed on the horizontal axis (in this case, frames 0 to 300).

5.3 Creating Interior Omni Lights

1. Open **Lakehouse-5.3.max**.
2. Verify that the top view is active, and then maximize it by pressing **ALT+W**.
3. Adjust the viewport so that the house fills the screen.
4. In the **Create** panel, choose the **Lights** category.

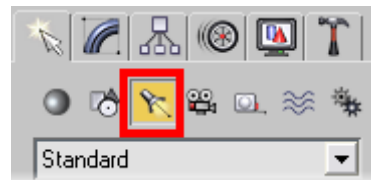

5. Select the **mr Area Omni** type.
6. Click in the center of the living room to create the light.

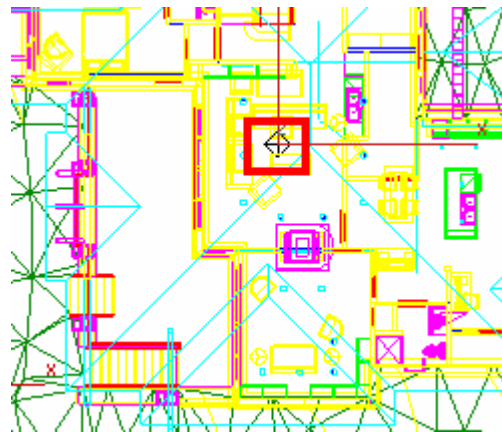

7. On the main toolbar, choose the **Move** tool.

An omni light is like a bulb. Light rays emanate in all directions.

When created, the light is positioned on the home grid (level 0). Its **Z**-coordinate needs to be adjusted to bring it up to the correct level.

8. In the transform type-ins at the bottom of the screen, set the **Z**-position value to **13'6"**.

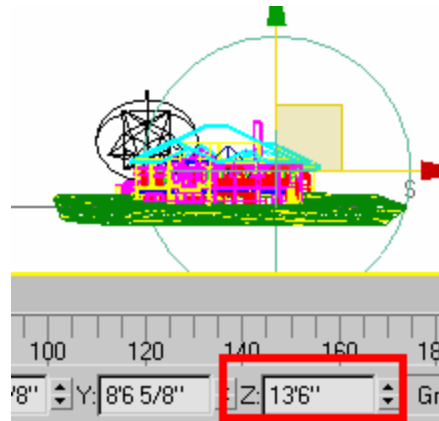

9. In the top view, press and hold **SHIFT** while moving the omni light toward the den.

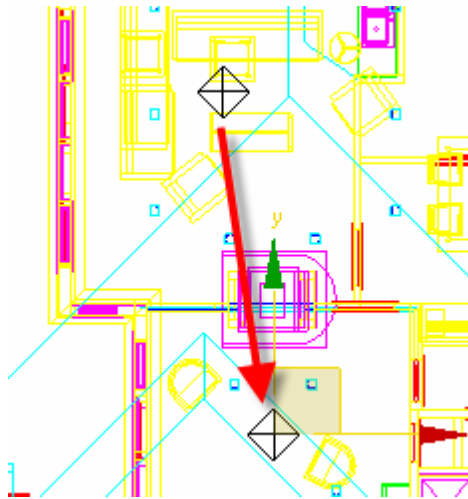

Holding the SHIFT key causes the object to be duplicated.

10. In the **Clone Options** dialog box, click **Instance**.

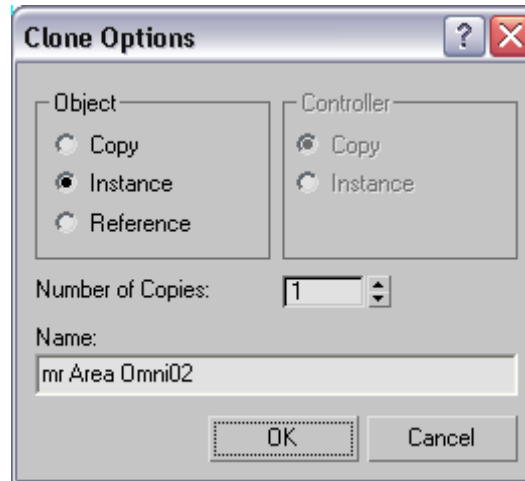

The second light is an instance of the first. Adjusting the parameters of either light affects both.

11. Click **OK** to complete the command.

12. With the second light selected, go to the **Modify** panel.

13. Open the **Intensity/Color/Attenuation** rollout.

14. Click the color swatch.



15. Set the RGB light color to **R:255, G:240, B:150**. This gives the omni lights a yellow tint.

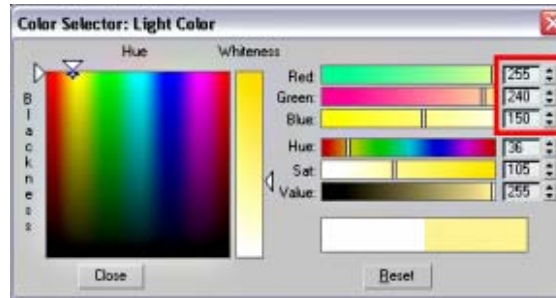

16. Under **Decay**, set **Type** to **Inverse Square** and **Start** to **50'0"**. A wireframe sphere appears around the selected light.

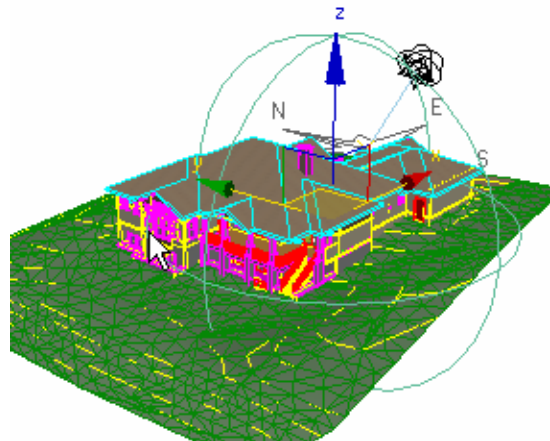
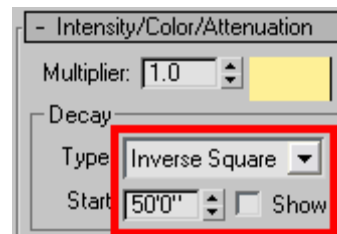

The **Inverse Square** decay simulates best how light energy decays in the real world. The decay **Start** distance value usually requires a bit of trial and error based on the scene you are working on.

Remember that changes applied to this light also affect its instances in the scene. Both interior lights now have a yellow tint and are set to attenuate starting from a distance of **50'-0"**.

5.4 Animating the Omni Lights

1. Open **Lakehouse-5.4.max**.
2. Select one of the two omni lights in the top view.
3. Go to the **Modify** Panel.
4. In the **Intensity/Color/Attenuation** rollout, set the **Multiplier** to **0**.
5. Move the time slider to frame **251**.



6. Click **Auto Key** to turn animation mode on.
7. In the **Modify** panel, set the **Multiplier** to **60**.

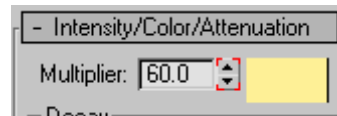

8. Disable **Auto Key** mode.
9. On the track bar in the bottom-left corner of the screen, select the keyframe at frame **0**.
10. Drag the keyframe to the right until it reaches frame **250**. Keep an eye on the **status bar** for reference.

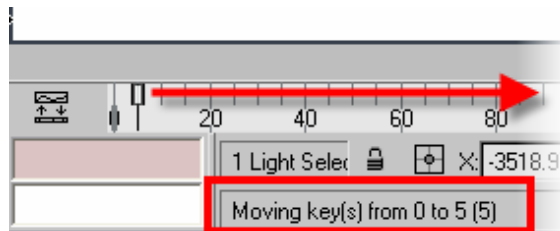

The light intensity is now animated to go from **0** to **60** between frames **0** and **251**. To simulate a light switch, the intensity change has to happen much faster.

As a result of these changes the light's multiplier value changes suddenly from **0** to **60** in the space of one frame (between frames **250** and **251**), which corresponds to **6 p.m.** The effect is demonstrated in the next unit: **Rendering**.

Unit 6: Rendering

6.1 Creating and Positioning a Camera

1. Open **LakeHouse-6.1.max**
2. Right-click the **Perspective** viewport label. Click **Views > Top**.

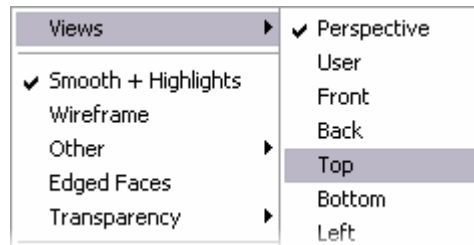

3. Zoom back to get a better view of the house and lake.
4. On the **Create** panel, select the **Cameras** category.

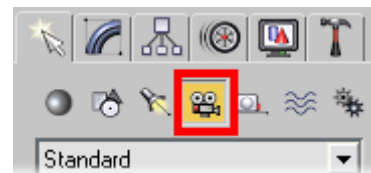

5. Click **Target**.

The top viewport can also be activated by pressing **T**.

Target and free cameras are the same, except that **Target** provides a helpful way for aiming the camera.

- Click and drag in the viewport to create a camera in approximately the position shown.

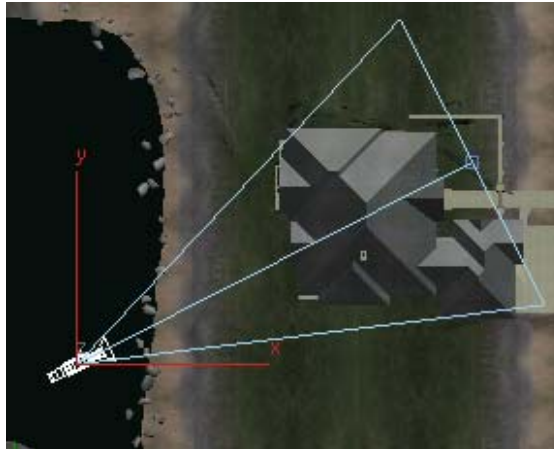

To position a target camera, click and drag from the position of the camera to that of the target.

- Go to the **Modify** panel.
- Under **Stock Lenses**, click **35mm**.

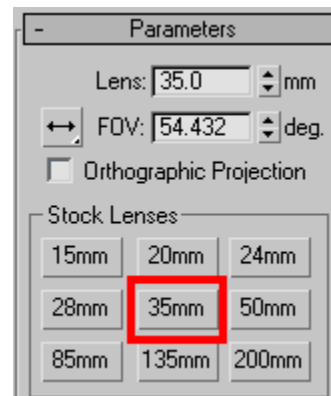

This sets the camera with a wide-angle shot. A **35mm** camera distorts the perspective slightly but captures more of the scene.

- Press **C** to view the scene through the camera lens.
- On the main toolbar, click the **Move** tool.
- In the type-in fields at the bottom of the screen, enter **X: -120'0"**, **Y: -18'0"** and

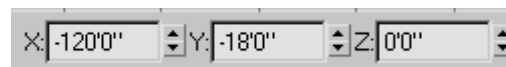

The camera and target coordinates are provided here for convenience. In practice, you

Z: 0.

12. Right-click in the viewport. Click **Quad** menu > **Select Camera Target** .



13. Set the target coordinates to **X: 41'0"**, **Y: 56'0"**, and **Z: 13'6"**.

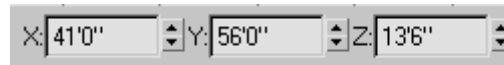

move the camera, its target, or both in any isometric view, and the camera viewport provides interactive feedback.

6.2 Using Camera Viewport Controls

1. Open **LakeHouse 6.2.max**.

In the following sequence you'll try several camera viewport controls. In each case you can cancel the view change by right-clicking or by pressing **ESC** before you release the left mouse button. If you inadvertently change the camera view, press **CTRL+Z** to undo the command.



2. Click the **Orbit Camera** icon.



3. Click and drag in the viewport to adjust the camera position, and then right-click before releasing the left mouse button.

The viewport navigation tools are in the bottom-right corner of the screen.

The **Orbit Camera** tool moves the camera around its target.

4. Press and hold the orbit tool, and click **Pan Camera** .



5. Click and drag in the viewport.

6. Click **Truck Camera**.

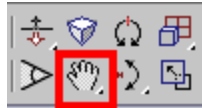

7. Click and drag in the viewport.

8. Click **Dolly Camera**.



9. Click and drag in the viewport.

Pan Camera moves the target about the camera.

Truck Camera moves the camera and its target in a direction perpendicular to the line of sight.

Dolly Camera moves the camera closer to its target.

6.3 Animating the Camera

1. Open **LakeHouse 6.3.max**.
2. Move the animation slider bar to the end of the animation (frame **300**).

3. Enable **Auto Key** animation mode.

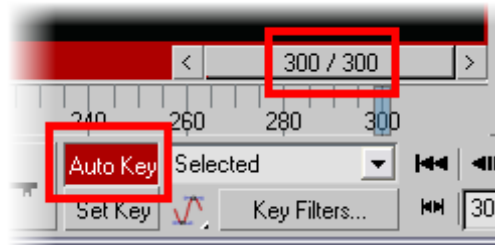

4. Click the **Dolly Camera** icon.
5. Click and drag upward in the camera viewport until the camera is closer to the house.



6. Disable **Auto Key**.
7. Play the animation.



The camera moves toward its target on playback.

6.4 Using the Render Dialog Box

1. Open **LakeHouse-6.4.max**.
2. Move the Time Slider to frame **150**.
3. On the main toolbar, click the **Render Scene Dialog** icon.
4. Verify that the **Common** tab is active.
5. Under **Time Output**, verify that **Single** is selected.
6. Under **Output Size**, click **800x600**.

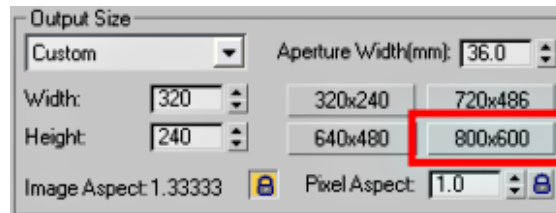
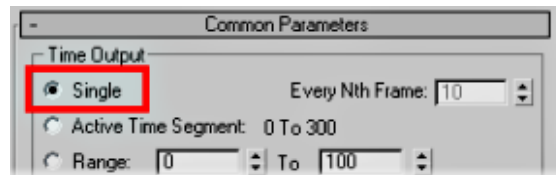
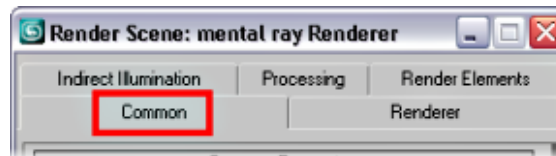

At frame **150** the front of the house is illuminated by the sun.

F10 also opens the Render dialog box.

Single causes the currently selected frame to be rendered.

7. Click **Render** at the bottom of the dialog box.



The scene renders, but areas in the shadows are too dark. In the real world, light bounces off surfaces to illuminate areas that are not under direct lighting.

6.5 Setting Final Gather

1. Continue with your existing file.
2. In the render window, click the **Clone Rendered Frame Window** icon. This clones the window so you can compare the last rendering with any new ones you create.
3. Open the **Indirect Illumination** rollout of the Render dialog box.
4. Under **Basic**, select the **Enable Final Gather** check box.



5. Select the **Draft** preset option.

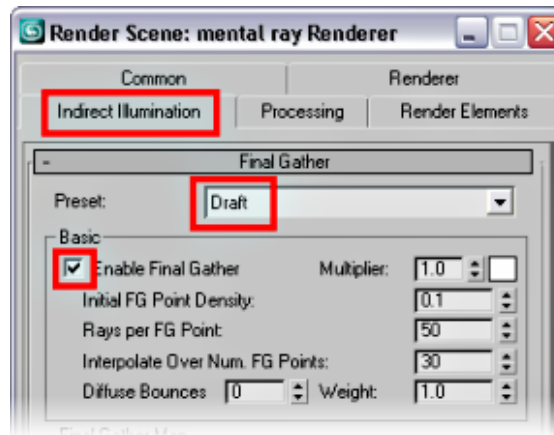

Presets offer a quick method for setting **Final Gather** parameters. Start with **Draft** and work your way up for better quality. In many cases, you will find draft mode to be satisfactory.

6. Click **Render**.



Final Gather has simulated indirect illumination so that areas in the shadows are now visible. Compare this last render with the previous one you did.

7. Close the **Render Dialog** and the render windows.

6.6 Saving a Rendered Image from the Framebuffer Window

1. Continue with your existing File.
2. Click **Rendering** menu > **Show Last Rendering**.

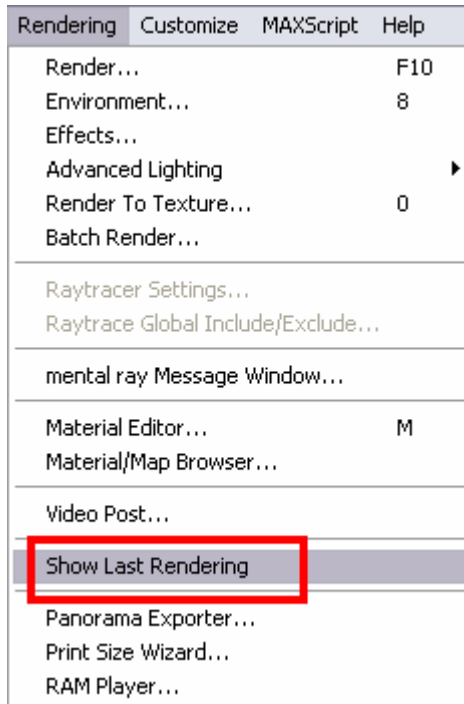

3. In the render window, click the **Save Bitmap** icon.



4. Select **JPEG File** from the file type list.

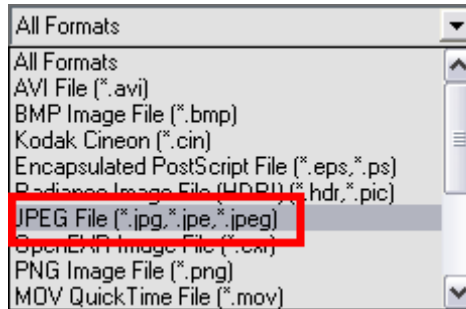

5. Enter **LakeHouse** as the file name.
Click **Save**.
6. In the dialog box that appears, set the JPEG quality to **100%**. Click **OK**. The image file is saved to disk.

JPEG file sizes are relatively small, even when set to high quality.

6.7 Saving Directly from the Render Dialog Box

1. Continue with your existing file.
2. Open the **Render** dialog box.
3. Under **Render Output**, select the **Save File** check box.
4. Click **Files**.



5. Choose the **JPEG** file type from the list.
6. Name the file **LakeHouse2**.

7. Click **Render**.
8. When the rendering is complete, close the **Render** dialog box.
9. Click **File** menu > **View Image File**.
10. Locate the file **LakeHouse2.jpg** you just saved, and click **Open** to view it.

6.8 Rendering an Animation

1. Open **LakeHouse-6.8.max**
2. Open the **Render** dialog box.
3. Under **Time Output**, click the **Active Time Segment**.
4. To speed up the process, set **Every Nth Frame** to **10**.

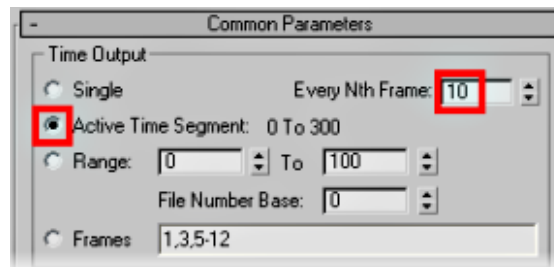

5. Under **Output Size**, click **320x240**.
6. Under **Render Output**, click **Files**.

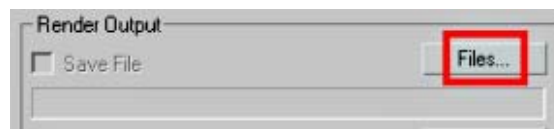

Setting **Every Nth Frame** to **10** causes 3ds Max to render every tenth frame. This speeds up the rendering by approximately 10 times and is useful for early evaluation of an animation.

7. Select **AVI File** from the file type list.

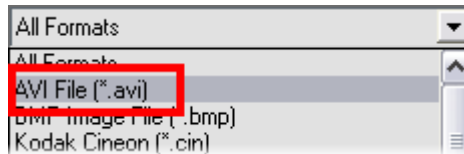

8. Enter **LakeHouse** in the Filename field.

9. Click OK to accept the default **Cinepak Codec by Radius**.

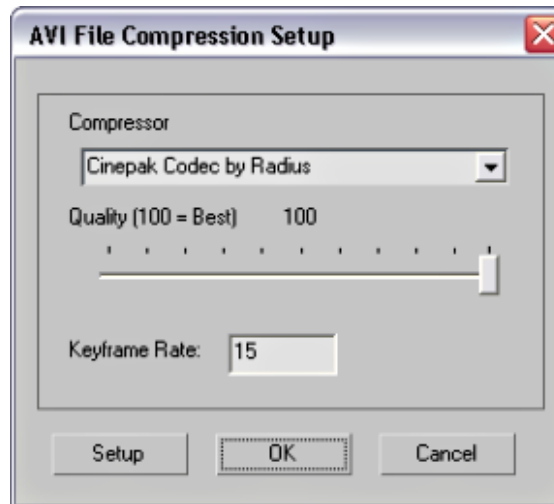

10. Click **Render** at the bottom of the dialog box.

11. Click **File** menu > **View Image File**.

The **Cinepak** compression codec creates AVI files that are relatively small and that play on any PC running on a Microsoft® Windows® platform.

Rendering the animation takes some time. During the process you see a progress indicator. For your convenience, a rendered version of this animation has been provided.

View Image File can be used for single images or animation files.

- Click **LakeHouse.avi** and click **Open**. The animation plays in Windows Media® Player.

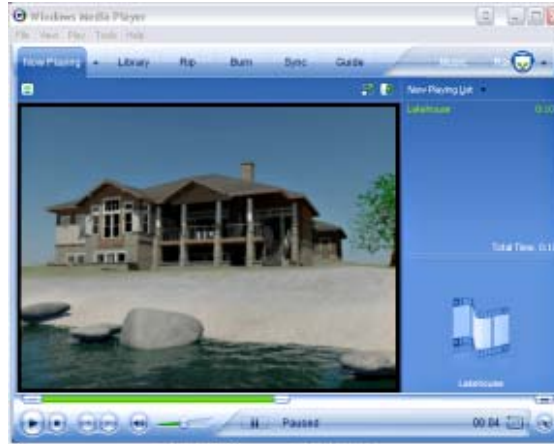

The animation shows a camera shot moving toward a house by the lake. Lighting changes as the environment shifts from morning to evening. As the sun goes down, the lights inside the house are switched on.