

# Autodesk® Certification Exam Guide

## Autodesk® Inventor® 2010

Preparation Guide for Autodesk Inventor 2010 Certified Associate and Autodesk Inventor 2010 Certified Professional Certification Exams.



This guide is intended as a resource in your preparation for the exams to become Autodesk certified. It will help you understand the structure and content of the exam, and to develop a personal strategy to successfully pass the Autodesk Inventor 2010 Certified Associate and Certified Professional exams, and includes information on re-certification from Autodesk Inventor 2009 Certified Professional.

### About Autodesk Professional Certification

Autodesk certifications are industry-recognized credentials that can help you succeed in your design career – providing benefits to both you and your employer. Autodesk certifications are a reliable validation of skills and knowledge, and can lead to accelerated professional development, improved productivity, and enhanced credibility.

### Getting Certified

To earn Autodesk Certification, you must pass the required Autodesk Certification exams. Step through each of these areas to help ensure your success:

- Choose the Certification that's right for you: Choose the level and the Autodesk application that best applies to you. Understand the requirements for the Certification you want to earn.
- Assess your readiness and take a practice test: Take an assessment test to assess your knowledge of the product. And then take a practice test for the Professional-level exam to gain experience using the testing system.
- Get the training you need: Autodesk Official Training Guides, or take classes at an Autodesk Authorized Training Center (ATC®).
- Apply your training and practice your skills: Practice what you've learned to gain experience.
- Take the required exam: Register for your exam at an Autodesk Authorized Certification Center.

Autodesk certification exams are delivered at Autodesk Authorized Certification Centers. All exams are computer-delivered in a proctored environment. You can find the locations of Autodesk Certification Centers near you using the Center Search function on [autodesk.starttest.com](http://autodesk.starttest.com)

**Autodesk®**  
Authorized Certification Center

### Content

Exam summary information	1 – 2
Recertification from 2009	2
Exam Preparation	3
Exam Preparation Solutions	3
Important Test Taking Strategies	4
Exam registration	5
Exam Sections and Objectives	6 – 7

# Autodesk® Certification

## Exam Summary Information

### Autodesk Inventor 2010 Certified Associate Exam Summary Information

The Autodesk Inventor 2010 Certified Associate exam is an on-line examination consisting of 30 questions that assess your knowledge of the tools, features, and common tasks in Autodesk Inventor 2010. Question types include multiple choice, matching, and point and click (hotspot).

The exam has a one hour time limit (in some countries the time limit may be extended). At the conclusion of the exam, you will receive a comprehensive score report which includes summary information on the questions you missed and where you can find information on that area in the corresponding Autodesk Official Training Guide.

### Autodesk Inventor 2010 Certified Professional Exam Summary Information

The Autodesk Inventor 2010 Professional Certification exam is a performance based test. Performance based testing is defined as testing by doing. That means that rather than answer questions about how you might accomplish a task, you actually perform the task.

The Autodesk Inventor 2010 Certified Professional exam is comprised of 20 questions. Each question requires you to use the Autodesk application to create or modify a data file, and then to type your answer into an input box on the screen. The answer you enter will either be a text entry or a numeric value. The exam has a 90 minute time limit (in some countries the time limit may be extended).

To earn the credential of Autodesk Inventor Certified Professional, you must also pass the Autodesk Inventor Certified Associate exam. You can pass the exams in any order.

### Example of Certified Professional Test Item

Open the drawing file **Copy-Dining-Chair.dwg**.

1. Using the insertion point of Dining Chairs "A and "B", copy the Dining Chairs, 712.8 units along the edge of the Dining Table as shown. Using the Distance command, what is the distance (to the nearest integer) from the corner of Dining Chair labeled "D" to the corner of Dining Chair labeled "E" as shown?

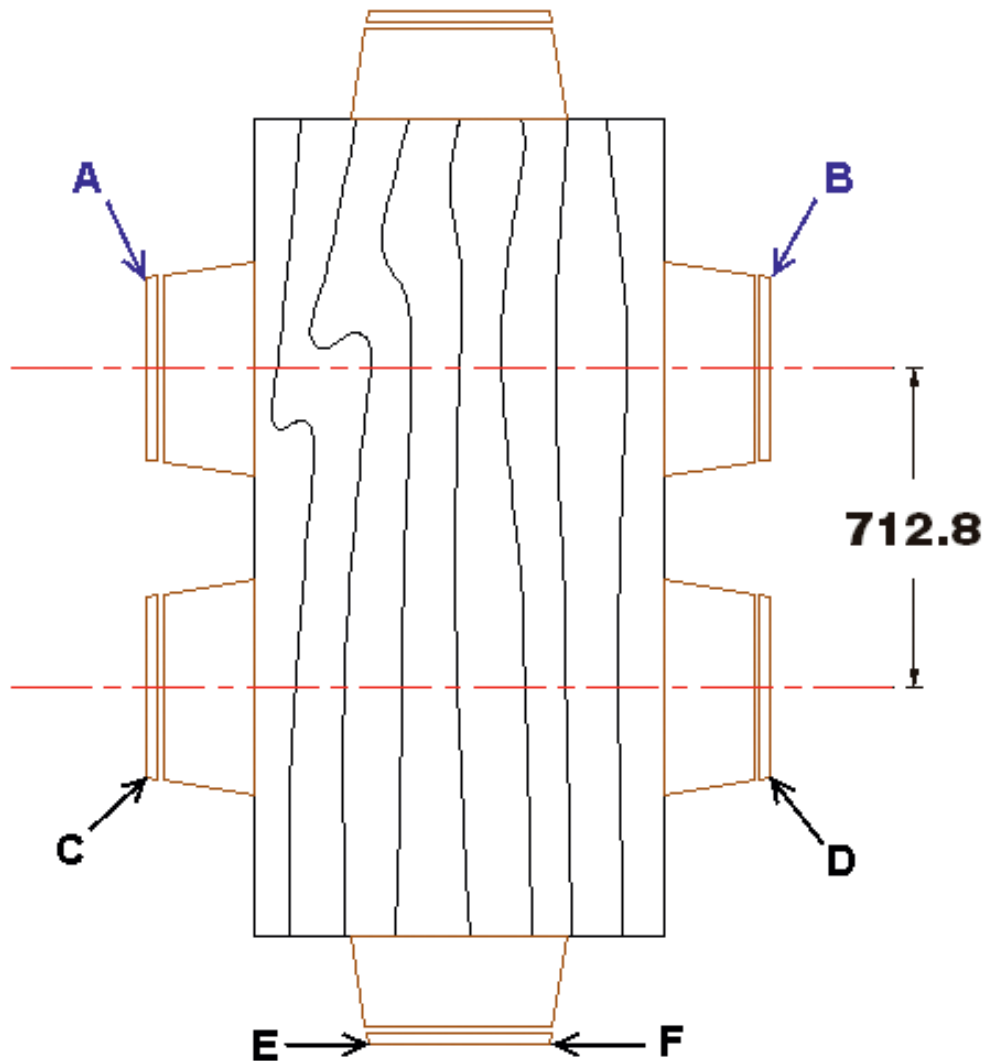

The answer is: 1081

# Autodesk® Certification Exam Guide

## Exam Preparation



### Recommended Experience Levels

**2010 Certified Associate exam** – Learning Autodesk Inventor 2010 course (or equivalent) plus 100 hours of hands-on application

**2010 Certified Professional exam** – Learning Autodesk Inventor 2010 course (or equivalent) plus 400 hours of hands-on application

### Exam Preparation – Your Key to Success

Autodesk highly recommends using a variety of resources to prepare for certification exams. In all cases, you should start with the exam objectives to determine which tasks will be covered on the exams. Equally as important, actual hands-on experience is required. From there, we recommend that you choose the preparation option that best fits your needs. Details on Autodesk recommended preparation solutions are available in this guide. During preparation, it is important that you review the exam objectives periodically to make sure that all of the material in the exam is covered in your choice of preparation methods. Please note that some material on the test may not be covered in your choice of preparation materials. This is why it is critical that you refer to the list of exam objectives during your course of study.

### Recommended Experience Levels for Autodesk Inventor 2010 Certification Exams

Actual hands-on experience is a critical component in preparing for the exam. Direct application of the skills learned cannot be substituted by any one other learning resource. You must spend time using the product and applying the skills you have learned.

Because experience using the Autodesk application is so important, we recommend a minimum level of experience before attempting the exam. Note that even with the recommended level of experience, you should still use the exam objectives as a basis for your preparation. Even the most knowledgeable and experienced users of Autodesk applications will need to focus their study specifically on the exam objectives.

### Exam Objectives

Review the exam objectives to see the complete listing of topics for the exam. Use this as your checklist to determine your weaknesses and areas on which you will want to focus more attention in your study and preparation.

You are  
**Autodesk Inventor 2009  
Certified Professional**

You must pass  
**Autodesk Inventor 2010  
Certified Associate**

You earn  
**Autodesk Inventor 2010  
Certified Professional**

### Re-certification from Autodesk Inventor 2009 Certified Professional

If you are an Autodesk Inventor 2009 Certified Professional you can update your certification to Autodesk Inventor 2010 Certified Professional by passing the Autodesk Revit Architecture 2010 Certified Associate exam as illustrated above. This applies only to re-certification from 2009 to 2010. If you are certified on an earlier release, you will have to take both the Certified Associate and Certified Professional exams to earn 2010 Certified Professional certification.



# Autodesk® Certification Exam Guide

## Certification Preparation Solutions

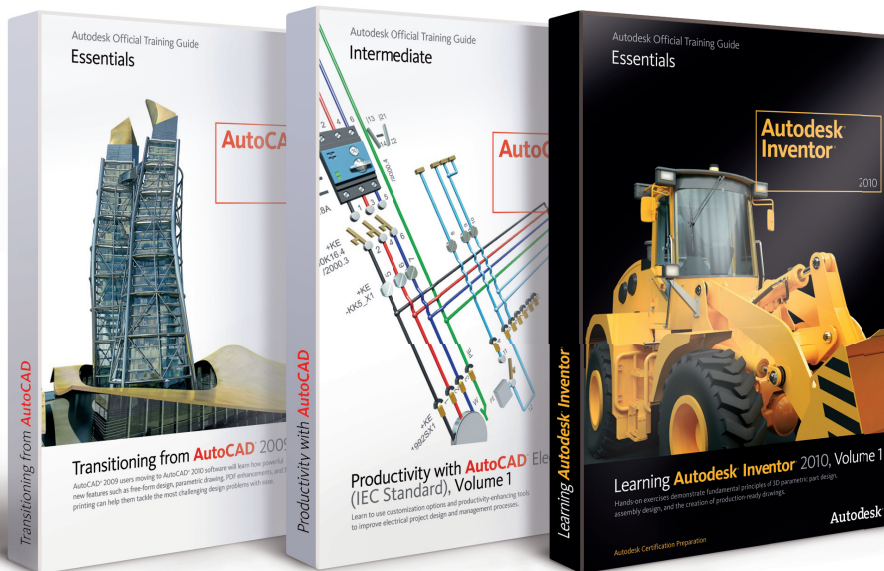

Example Training Guides from Autodesk

### Autodesk Assessment Tests

Autodesk assessment tests will help determine your general knowledge of the Autodesk application on which you are seeking certification. This will identify areas of knowledge that you should develop in order to prepare for the certification exam. At the completion of an Autodesk Assessment test you will receive a comprehensive score report and also be able to review the items you missed and their correct answers. Assessment tests can be purchased at [autodesk.starttest.com](http://autodesk.starttest.com).

### Autodesk Official Training Guides

Autodesk publishes dozens of Training Guides every year designed to help users at all levels of expertise improve their productivity with Autodesk software. Training Guides from Autodesk are the preferred classroom training material for Autodesk Training Centers. These same Training Guides are well-suited for self-paced learning.

Students simulate real-world projects and work through hands-on, job-related exercises. Most titles include a trial version of the software. The objectives in the Autodesk Certified Associate and Professional exams come directly from Autodesk Official Training Guides. If you will be taking a professional level exam the test questions will use the drawings that are made available to you with the corresponding Autodesk Official Training Guides.

The recommended Autodesk Official Training Guides for the Associate and Professional exam is Learning Autodesk Inventor 2010. You can purchase the courseware at [store.autodesk.com](http://store.autodesk.com) or contact your local ATC. Academic Centers in North America can purchase guides from an Autodesk Academic Value Added Reseller at [autodesk.com/education](http://autodesk.com/education) and select “locate a reseller”.

### ATC® Instructor-Led Courses

Every day, thousands of customers are taught how to realize their ideas, faster, with Autodesk software. You can perform smarter and better with Autodesk software products when you turn to an Authorized Training Center. An ATC is your best source for Autodesk-authorized classes, tailored to meet the needs and challenges facing today’s design professionals, and to help you prepare for your Autodesk Certification exams.

The Autodesk Authorized Training Center (ATC®) program is a global network of professional training providers offering a broad range of learning resources. In many areas, you can earn continuing education credits while building your toolset. Visit the online ATC locator at [autodesk.com/atc](http://autodesk.com/atc).

### Autodesk Inventor 2010 Professional Level Practice Tests

In order to allow you to gain experience with the Professional level test and the testing system, Autodesk has developed a practice test that simulates the actual 2010 Certified Professional certification exam. It is a performance based exam, with the same number of questions as the actual exam. It requires the use of the specific Autodesk application in order to successfully answer the questions. This test can be taken in an Autodesk Certification Center or from your own computer. For more information on purchasing Autodesk Professional Practice tests see [autodesk.starttest.com](http://autodesk.starttest.com).

### Test Taking Strategies

Each time you take a test, whether it is an assessment test, practice test, or the certification exam, you will benefit from using proven test taking strategies to increase your odds of success. Some of these strategies are general, but some are very specific to the type of exam you may be taking.

### Time Management

Because Autodesk certification exams are timed, management of time during testing is an integral part of a successful outcome. Autodesk recommends that you use a strategy that maximizes the time available so that you will have time to answer each exam question. The Autodesk Online test system allows you to mark questions for review and return to them later. This allows you to work through the test questions that are easy or quick for you, and mark the more difficult questions to return to later if time permits. It is important to not allow yourself to become caught up in one specific exam question and waste time. Also, be sure to check the review screen before you submit your exam, to make sure you have answered all of the items.

### Thoroughly Read Exam Questions and Instructions

Autodesk exams are testing specific objectives so it is critical that you understand the questions before you answer them. Additionally, before each test you are presented with a tutorial. This tutorial contains information on using the Autodesk Online testing system as well as critical information such as location of files, instructions for answering questions, and general test information.

# Autodesk® Certification Exam Guide

## Exam Registration, Purchase, and Scheduling



Leveraging the Autodesk brand can help you in your career. Autodesk Certification provides you with an Autodesk logo that you can display on your resume and business card, and a beautiful e-certificate suitable for framing.

This customized certificate gives instant recognition that your credential is issued by Autodesk.

### Exam Registration, Purchase, and Scheduling

When you are ready to take your exam, you may purchase your exam directly from the Autodesk Online Testing Service or from an Autodesk Authorized Certification Center depending on the country in which you will test. Information on purchasing and scheduling your exam can be found at [autodesk.starttest.com](http://autodesk.starttest.com).



### During Your Exam

While taking the exam, you may not use calculators, books, or other electronic equipment. You may use scratch paper, but it will be collected from you when you finish your test. You may pause the test during delivery, and no time will be lost. The proctor will seat you and step you through the process of starting your test. They will also answer any questions you have about the testing process. They will not answer any questions about test questions or the content of the test.

### After Your Exam

After your certification exam you will immediately receive an online score report that contains diagnostic feedback. This feedback includes the number of items that are correct in each section. This score report contains the objectives for any items that were incorrect. This score report is available in your Autodesk Online profile, and can be reviewed and printed at anytime from [autodesk.starttest.com](http://autodesk.starttest.com).

If you passed the required exams to earn certification, you will also have access to electronic certificate: suitable for printing and framing. You will also have access to official Autodesk certification logos which you can use on your business cards, resume, and letterhead. The certificate and logos are available in your certification profile.

Once certified, you can also choose to have your contact information and certifications listed in Autodesk's publicly available database. This is an excellent way to demonstrate your certification status to prospective employers. The database listing can be found on [autodesk.starttest.com](http://autodesk.starttest.com). In order to display your certification log into your Autodesk Online profile and select "yes" to the field "I would like my certification status published to the Autodesk website". You may change this field at anytime to remove or display your certifications.

Sample Autodesk Certification Score report

Scores by Section		
Section Name	# of Questions	Incorrect Question #
<b>Manipulating Objects</b>		
# of Questions	5	1
# of Correct Questions	3	3
% of Correct Questions	60%	
<b>Drawing Organization and Inquiry Commands</b>		
# of Questions	1	
# of Correct Questions	1	
% of Correct Questions	100%	
<b>Altering Objects</b>		
# of Questions	2	
# of Correct Questions	2	
% of Correct Questions	100%	
<b>Working with Layouts</b>		
# of Questions	1	
# of Correct Questions	1	
% of Correct Questions	100%	
<b>Annotating the Drawing</b>		
# of Questions	3	11
# of Correct Questions	2	
% of Correct Questions	67%	
<b>Dimensioning</b>		
# of Questions	3	
# of Correct Questions	3	
% of Correct Questions	100%	

# Autodesk® Inventor® 2010

## Certified Associate Exam Sections and Objectives

The Autodesk Official Training Guide for this exam is Learning Autodesk Inventor 2010. You can purchase this guide at [store.autodesk.com](http://store.autodesk.com) or from your local ATC. Schools can also purchase from an Autodesk Academic Value Added Reseller at [autodesk.com/education](http://autodesk.com/education) and select “locate a reseller”.

Section	Exam Objectives	Autodesk Official Training Guide Chapter
<b>Getting Started With Autodesk Inventor</b>	<ul style="list-style-type: none"><li>- Identify the tools that are available in the graphics window.</li></ul>	<b>Chapter 1:</b> Getting Started
<b>Basic Sketching Techniques</b>	<ul style="list-style-type: none"><li>- Apply geometric constraints to sketch geometry.</li><li>- Use additional options when applying dimensions.</li></ul>	<b>Chapter 2:</b> Basic Sketching Techniques
<b>Basic Shape Design</b>	<ul style="list-style-type: none"><li>- Use the Extrude tool to create extruded features.</li><li>- Use the Operation and Extent termination options when adding 3D features.</li><li>- Describe sketch linetypes and their behavior.</li><li>- Create and modify parameters and equations.</li><li>- Use the Sweep tool to create sweep features that follow 2D and 3D paths.</li></ul>	<b>Chapter 3:</b> Basic Shape Design
<b>Detailed Shape Design</b>	<ul style="list-style-type: none"><li>- Define a hole feature.</li><li>- Use the Rectangular Pattern tool to create rectangular patterns.</li><li>- Use the Shell tool to create shelled features.</li></ul>	<b>Chapter 4:</b> Detailed Shape Design
<b>Assembly Design Overview</b>	<ul style="list-style-type: none"><li>- Create a project file for a single user.</li></ul>	<b>Chapter 5:</b> Assembly Design Overview
<b>Placing, Creating, and Constraining Components</b>	<ul style="list-style-type: none"><li>- Describe how assembly constraints affect individual parts in the assembly.</li><li>- Describe the Content Center consumer environment and what Content Center consumers can do.</li><li>- Create components in an assembly.</li></ul>	<b>Chapter 6:</b> Placing, Creating, and Constraining Components
<b>Interacting with an Assembly</b>	<ul style="list-style-type: none"><li>- Use the Selection Priority and Component Selection tools to simplify and enhance component selection.</li><li>- Calculate physical properties.</li><li>- Describe presentation files and their role in creating exploded drawing views.</li></ul>	<b>Chapter 7:</b> Interacting with an Assembly
<b>Basic View Creation</b>	<ul style="list-style-type: none"><li>- Edit orthographic views and describe how other projected views may be affected.</li><li>- Edit section views.</li><li>- Crop a drawing view using a sketched boundary shape.</li><li>- Move, align, and edit drawing views.</li></ul>	<b>Chapter 8:</b> Basic View Creation
<b>Dimensions, Annotations, and Tables</b>	<ul style="list-style-type: none"><li>- Create and edit hole tables.</li><li>- Create centerlines and center marks.</li><li>- Add and edit revision tags.</li><li>- Position model dimensions, add text and symbols, and edit model dimension values.</li></ul>	<b>Chapter 9:</b> Dimensions, Annotations, and Tables
<b>Annotating Assembly Drawings</b>	<ul style="list-style-type: none"><li>- Describe the bill of materials and its uses.</li><li>- Use the Edit Parts List dialog box to modify your parts lists.</li><li>- List the steps required to manually place and edit balloons.</li></ul>	<b>Chapter 10:</b> Annotating Assembly Drawings
<b>Drawing Standards and Resources</b>	<ul style="list-style-type: none"><li>- Describe styles and their role in drawing standards.</li></ul>	<b>Chapter 11:</b> Drawing Standards and Resources

# Autodesk® Inventor® 2010

## Certified Professional Exam Sections and Objectives

The Autodesk Official Training Guide for this exam is Learning Autodesk Inventor 2010. You can purchase this guide at [store.autodesk.com](http://store.autodesk.com) or from your local ATC. Schools can also purchase from an Autodesk Academic Value Added Reseller at [autodesk.com/education](http://autodesk.com/education) and select “locate a reseller”.

Section	Exam Objectives	Autodesk Official Training Guide Chapter
<b>Basic Sketching Techniques</b>	<ul style="list-style-type: none"><li>- Describe best practices for dimensioning your sketch</li></ul>	<b>Chapter 3:</b> Basic Shape Design
<b>Basic Shape Design</b>	<ul style="list-style-type: none"><li>- Extruded Features – Orient sketch planes based on other planes or faces.</li><li>- Revolved Features – Orient sketch planes based on other planes or faces.</li><li>- Project part edges onto a sketch plane.</li><li>- Utilize the 3D Grips tool and adjust the geometry a visual distance, a numeric distance, or to a specific geometric location.</li><li>- Use the Work Plane tool to create work planes on a part.</li><li>- State the guidelines for creating sweeps.</li></ul>	<b>Chapter 3:</b> Basic Shape Design
<b>Detailed Shape Design</b>	<ul style="list-style-type: none"><li>- State the guidelines for creating chamfers and fillets.</li><li>- Use the Hole tool to create hole features.</li><li>- Use the Mirror tool to create symmetric features.</li><li>- Create pattern features.</li><li>- Use the Shell tool to create shelled features.</li></ul>	<b>Chapter 4:</b> Detailed Shape Design
<b>Placing, Creating, and Constraining Components</b>	<ul style="list-style-type: none"><li>- State some guidelines for proper constraining techniques.</li><li>- Use the Content Center consumer environment to place, change, and open Content Center components.</li><li>- State some guidelines for in-place component design.</li></ul>	<b>Chapter 6:</b> Placing, Creating, and Constraining Components
<b>Interacting with an Assembly</b>	<ul style="list-style-type: none"><li>- Animate components in an assembly by driving constraints.</li></ul>	<b>Chapter 7:</b> Interacting with an Assembly
<b>Basic View Creation</b>	<ul style="list-style-type: none"><li>- Control hatch and sectioning in section views.</li></ul>	<b>Chapter 8:</b> Basic View Creation
<b>Dimensions, Annotations, and Tables</b>	<ul style="list-style-type: none"><li>- Dimension drawing views.</li></ul>	<b>Chapter 9:</b> Dimensions, Annotations, and Tables
<b>Annotating Assembly Drawings</b>	<ul style="list-style-type: none"><li>- Use the Edit Parts List dialog box to modify your parts lists.</li></ul>	<b>Chapter 10:</b> Annotating Assembly Drawings
<b>Drawing Standards and Resources</b>	<ul style="list-style-type: none"><li>- Set drawing standards.</li></ul>	<b>Chapter 11:</b> Drawing Standards and Resources

### For further information:

[autodesk.com/certification](http://autodesk.com/certification)

email: [certification@autodesk.com](mailto:certification@autodesk.com)