

Digital Prototyping for the Manufacturing Market

Autodesk is a world-leading supplier of engineering software, providing companies with tools to help them experience their ideas before they are real. By putting powerful Digital Prototyping technology within the reach of mainstream manufacturers, Autodesk is changing the way manufacturers think about their design processes and is helping them create more productive workflows. The Autodesk approach to Digital Prototyping is unique in that it is scalable, attainable, and cost-effective, which allows a broader group of manufacturers to realize the benefits with minimal disruption to existing workflows, and provides the most straightforward path to creating and maintaining a single digital model in a multidisciplinary engineering environment.

Learn More or Purchase

Access specialists worldwide who can provide product expertise, a deep understanding of your industry, and value that extends beyond your software purchase. To purchase AutoCAD Mechanical, contact an Autodesk Premier Solutions Provider or Autodesk Authorized Reseller. Locate a reseller near you at visit <http://asean.autodesk.com/resellers>.

Autodesk Learning and Education

From instructor-led or self-paced classes to online training or education resources, Autodesk offers learning solutions to fit your needs. Get expert guidance at an Autodesk Authorized Training Center (ATC®) site at <http://asean.autodesk.com/atc>. To learn more about Autodesk's academic solutions and programmes, and download free software* for students and faculty members, go to <http://asean.autodesk.com/education>.

Autodesk Services and Support

Accelerate return on investment and optimize productivity with innovative purchase methods, companion products, consulting services, and support from Autodesk and Autodesk authorized partners. Designed to get you up to speed and keep you ahead of the competition, these tools help you make the most of your software purchase—no matter what industry you are in. Learn more at <http://asean.autodesk.com/servicesandsupport>.

Autodesk Subscription

Get the benefits of increased productivity, predictable budgeting, and simplified license management with Autodesk® Subscription. You get any new upgrades of your Autodesk software and any incremental product enhancements, if these are released during your Subscription term. In addition, you get exclusive license terms available only to Subscription members. A range of community resources, including web support direct from Autodesk technical experts, self-paced training, and e-Learning, help extend your skills and make Autodesk Subscription the best way to optimize your investment. Learn more at <http://asean.autodesk.com/subscription>.

**Free products are subject to the terms and conditions of the end-user license agreement that accompanies download of this software.

Cover image courtesy of Prensa Jundiá, Brasil

Autodesk, AutoCAD, Autodesk Inventor, and Inventor are registered trademarks or trademarks of Autodesk, Inc., and/or its subsidiaries and/or affiliates in the USA and/or other countries. All other brand names, product names, or trademarks belong to their respective holders. Autodesk reserves the right to alter product offerings and specifications at any time without notice, and is not responsible for typographical or graphical errors that may appear in this document.

© 2009 Autodesk, Inc. All rights reserved. 206A1-000000-MZ02

Power tools for mechanical design.

AutoCAD[®]

Mechanical

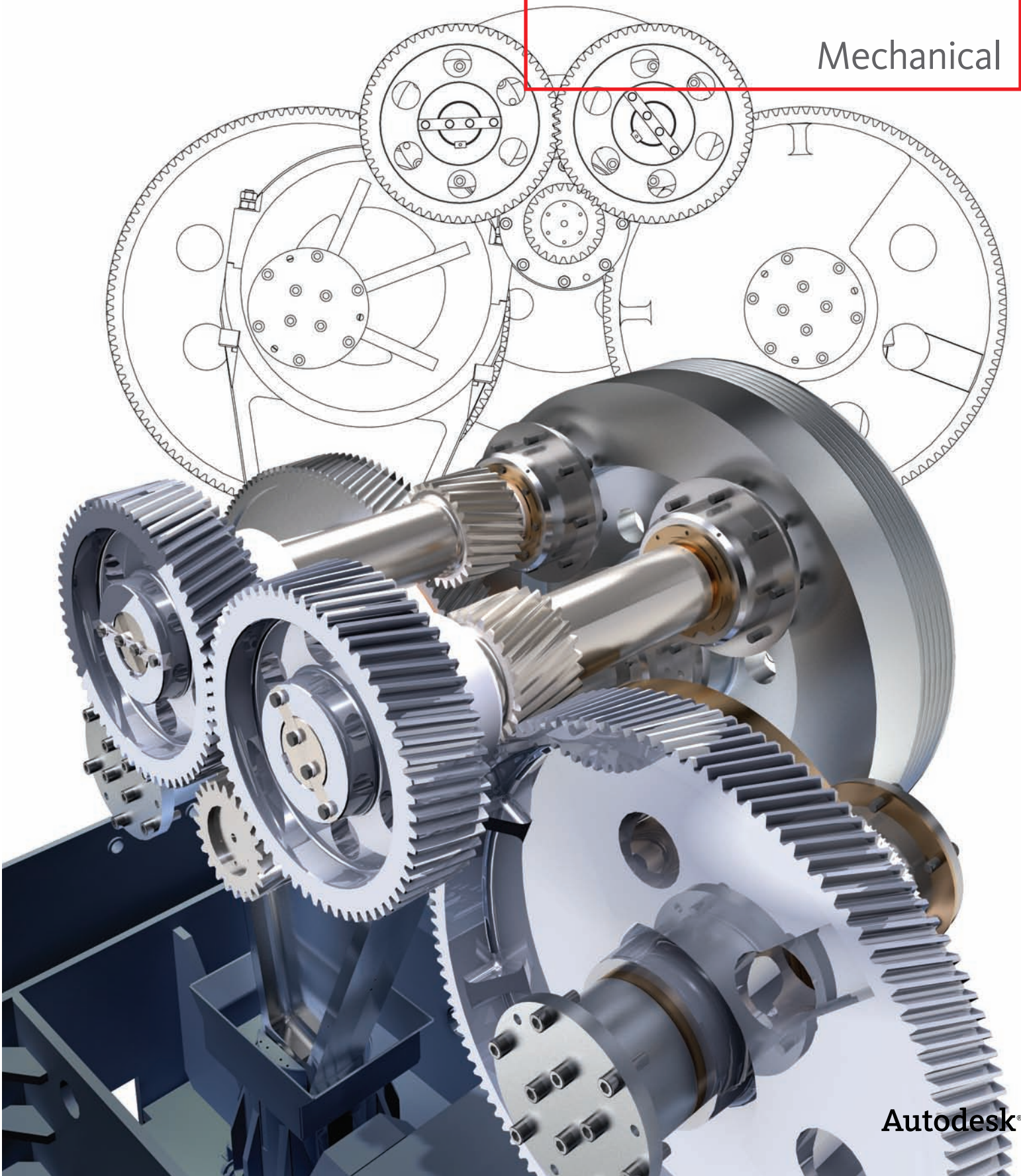

Autodesk[®]

The AutoCAD Mechanical Advantage

To compete and win in today's design marketplace, engineers need to create and revise mechanical drawings faster than ever before. AutoCAD® Mechanical is AutoCAD® software for manufacturing, offering significant productivity gains over standard AutoCAD® by simplifying complex mechanical design work.

Facing these issues?

- Productivity is limited by software that is not built specifically for mechanical design.
- Frequent design changes are creating hours of manual rework.
- Design errors and incorrect bills of materials (BOMs) and parts lists are keeping products from shipping on time.
- Updating existing drawings is costing your company valuable time.
- Inconsistent use of drafting standards is slowing down shop-floor production.
- Inability to find and reuse designs is forcing your teams to create too many drawings from scratch.

Discover why so many designers and drafters are switching to AutoCAD Mechanical.

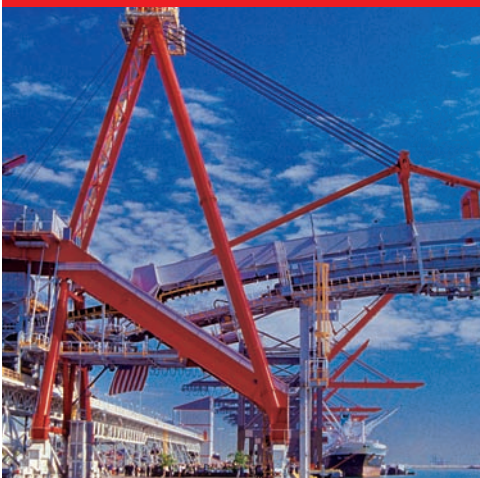

Image courtesy of Thyssen-Krupp Corporation

The Standard in 2D Mechanical Design

With comprehensive libraries of standards-based parts, and tools for automating common design tasks, AutoCAD® Mechanical software accelerates the mechanical design process. AutoCAD Mechanical provides innovative design and drafting tools that are wholly focused on ease of use for the AutoCAD user. Keeping the AutoCAD user experience intact enables designers to maintain their existing workflows while adopting the enhanced functionality of AutoCAD Mechanical at their own pace. Designers gain a competitive edge by saving countless hours of design and rework, so they can spend time innovating rather than managing workflow issues.

Maximize Your Productivity

Creating mechanical designs often requires spending valuable time on manual workarounds to get the job done. Since AutoCAD Mechanical provides a simplified drafting environment for manufacturing and automates many manual tasks, it improves the design experience and offers immediate efficiency gains. AutoCAD Mechanical delivers high-impact productivity tools to AutoCAD users who are performing updates and iterative design changes, reducing the amount of rework associated with these tasks. In addition, powerful dimensioning tools make adding, deleting, and editing dimensions fast and easy. Built to save you time, AutoCAD Mechanical has a specific tool for almost every aspect of the mechanical drafting process.

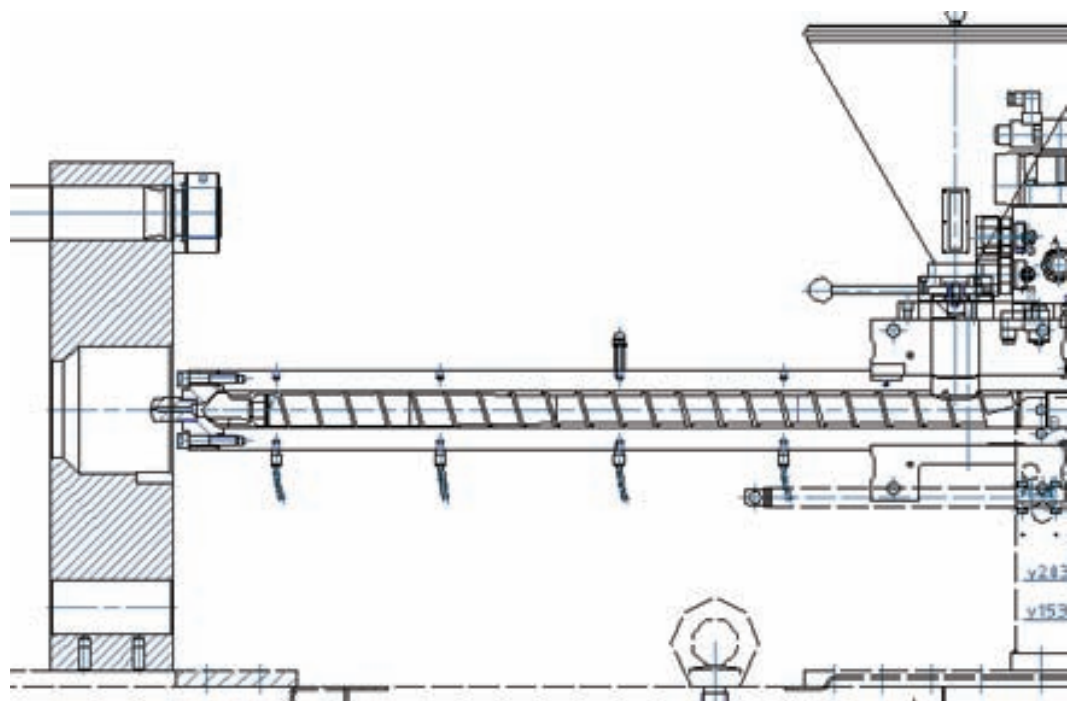
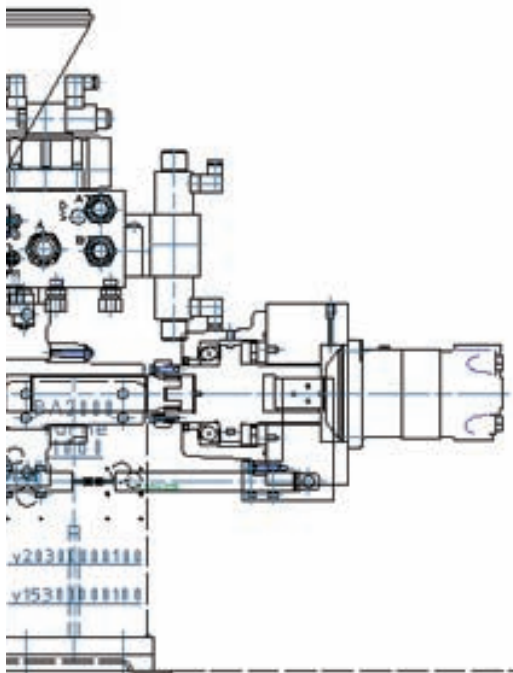



Image courtesy of
Parker Hannifin Corporation

Reduce Errors and Inconsistencies

When creating mechanical drawings, designers can sometimes inadvertently introduce errors and design inconsistencies, wasting time and money. AutoCAD Mechanical includes libraries of more than 700,000 standard parts and supports international drafting standards, enabling users to consistently meet design requirements in the global marketplace. AutoCAD Mechanical also enables detailers to document native Autodesk® Inventor® models in the familiar AutoCAD drafting environment. This associative workflow automatically synchronizes drawings with the 3D model, which reduces errors and inconsistencies and saves hours of rework. Clear and consistent communication in the design and documentation process helps team members avoid delays and errors on the shop floor, so your company can stay ahead of the competition.



Manage Design Data More Effectively

Once a design is complete, it is important to share accurate design and part information with the teams responsible for ordering and manufacturing the product. Using software that is not purpose-built for these tasks often means creating crucial parts lists and BOMs by hand. With manual methods, even the smallest design change can introduce errors, resulting in delivery delays to the customer.

To help your company prevent errors and costly delays, AutoCAD Mechanical is tightly integrated with Autodesk Data Management applications, enabling the efficient and secure exchange of design data and promoting earlier collaboration between design and manufacturing workgroups. Different workgroups can manage and track all components of a digital prototype with free** Autodesk® Design Review software—the all-digital way to review, measure, mark up, and track changes to designs—allowing for better reuse of crucial design data, management of BOMs, and collaboration with other teams and partners.

Now Is the Time

Want to get unparalleled productivity from your 2D mechanical design process? Now is the time to make the move to AutoCAD Mechanical.

Top 10 Reasons to Move from AutoCAD to AutoCAD Mechanical

1. 700,000 Standard Parts and Features
2. Extended Draw Toolbar for Manufacturing
3. Powerful and Smart Dimensions
4. Reusable Detailing Tools
5. Support for International Drafting Standards
6. Associative Balloons and BOMs
7. Layer Management
8. Hidden Lines
9. Machinery Generators and Calculators
10. Data Exchange Between CAD Systems

Visit www.autodesk.com/autocadmechanical-productivity for more details.