

Enhanced Piping Design

Autodesk® Building Systems software provides tools for accelerated production of piping design layouts. This white paper discusses the piping enhancements in Autodesk Building Systems and explains functionality associated with the piping design tools.

CONTENTS

Defining Pipe and Fittings in Building Systems.....1

Content of the Pipe Catalog2

Building Systems Pipe Connections3

Creating a Piping Layout.....6

Summary12

Defining Pipe and Fittings in Building Systems

When designing a piping system, designers must answer two key questions: how big is the pipe and how durable does the pipe need to be? In the computer-aided design (CAD) modeling and drafting world, the answers to those questions are Nominal Size and Pressure Rating or Pressure Class, because these properties are what directly affect the physical sizes of the pipe and fittings.

Therefore, it would only make sense that in Building Systems, pipe and pipe fittings are defined by nominal size and pressure class. In Autodesk® Building Systems the pipe catalog is now organized by both nominal size and pressure class, giving users a straightforward way of recognizing pipe and fittings. Notice that in Figure 1 the Flange objects are categorized by Class. Class refers to a pressure class. In this case, the standard pressure classes for flanged joints are set according to American Society of Mechanical Engineers (ASME) B16.5 and are 150, 300, 400, 600, 900, 1500, and 2500 pounds.

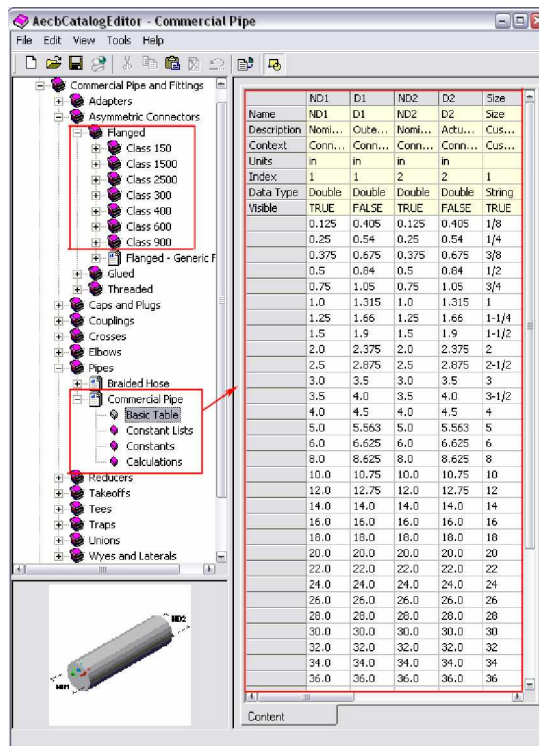

Figure 1: Commerical Pipe catalog in Catalog Editor.

It is important to note that just as pipes and fittings are separate entities in the real world, they are also separate objects in Building Systems software. There is only one commercial pipe object with one set of nominal sizes. Commercial pipe is manufactured to always have the same outer diameter (OD). The wall thickness of the pipe is commonly referred to as a *Schedule*. The most common thickness for commercial steel pipe is Schedule 40, which is also referred to as *Schedule Standard*. Pipe designers typically don't take Schedule into account because wall thickness grows inward for pipe and the OD is always the same. For this reason the catalog requires only a single set of commercial pipe sizes, which can have any number of joint and fitting objects holding them together.

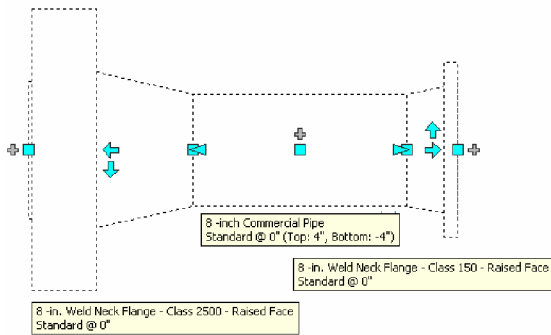

Figure 2 is an extreme example of a piece of pipe with a Class 150 Weld Neck Flange on one side and a Class 2500 Weld Neck Flange on the other. Both flanges were made to fit on the same pipe object.

Figure 2: Pipe object with weld neck flanges.

Content of the Pipe Catalog

Considering that one standard does not fit everyone, the Building Systems pipe catalog has been consolidated into three main groups: Commercial, Ductile Iron, and Tube (Figure 3). Each of these pipe groups has unique ODs, therefore requiring different fittings to hold them together. Hence the reason for separate groups.

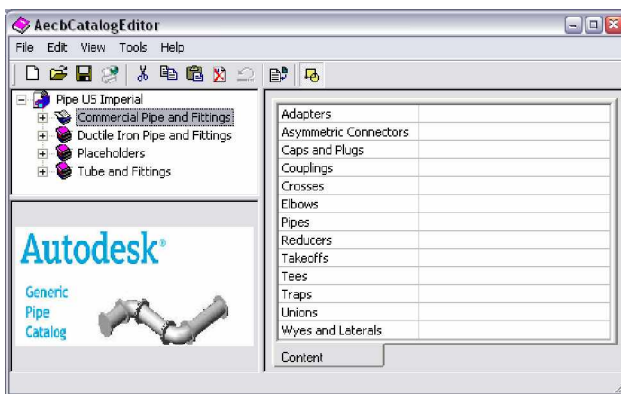

Figure 3: Pipe Catalog in Catalog Editor.

Within each of those pipe groups are the various types of fitting connections (flanged, threaded, butt welded, and so forth), which are then broken down by pressure class. The following table depicts what is included in the Autodesk Building Systems piping catalog.

Note: Any reference to materials in the name of Building Systems objects is based on common industry language and does not necessarily reflect the actual material specifications for the pipe and fittings.

Commercial Pipe and Fittings	
Butt Welded	ASME B16.9 Factory-Made Wrought Butt Welding Fittings
Flanged	ASME B16.5 Pipe Flanges and Flanged Fittings
Threaded	ASME B16.11 Forged Fittings, Socket-Welding, and Threaded ASTM D 2464 and D 2467 PVC Schedule 80 Threaded Fittings ASTM D 2466 PVC Schedule 40 Socket and Threaded Fittings ASTM F 437 CPVC Schedule 80 Threaded Fittings
Socket Welded	ASME B16.11 Forged Fittings, Socket-Welding, and Threaded
Glued	ASTM D 2464, D 2466, D 2467, F 439 CPVC Schedule 80 Socket Fittings
Grooved	Sizes taken from manufacturer's cutsheets
Ductile Iron Pipe and Fittings	
Flanged	ANSI/AWWA C110/A21.10-03 Ductile Iron and Gray Iron Fittings for Water ANSI/AWWA C153/A21.53-00 Ductile Iron Compact Fittings for Water ANSI/AWWA C115/A21.15-05 Ductile Iron Pipe with Threaded Flanges
Threaded	ASME B16.3 Malleable Iron Threaded Fittings
Tube and Fittings	
Brazed	ASME B16.18 Cast Copper Alloy Solder Joint Pressure Fittings ASME B16.22 Wrought Copper and Copper Alloy Solder Joint Pressure Fittings ASME B16.23 Cast Copper Alloy Solder Joint Drainage Fittings DWV ASME B16.29 Wrought Copper and Wrought Copper-Alloy Solder Joint Drainage Fittings
Threaded	ASME B16.15 Cast Bronze (Copper Alloy) Threaded Fittings

Building Systems Pipe Connections

In Building Systems the connection between fittings and pipe is determined by the “connectors” on the pipe. Each fitting type (flanged, thread, butt welded, and so forth) has a unique connection type. Pipe that is not connected to anything has an “undefined” connection type. Once it is connected it inherits the connection type of the object it is connected to.

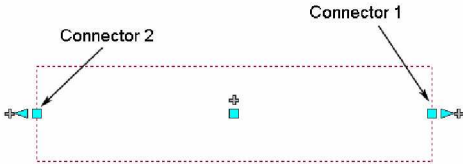
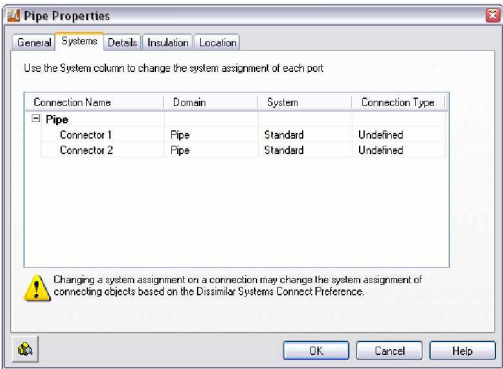

Figure 4: Pipe with undefined connections.

When specifying connections between pipe and fittings, designers must take into account the amount of pipe that must go into the fitting when actually constructed. In fact, this length is so important that it is known in the industry as *engagement length*. The engagement length or CEL (Connector Engagement Length) value is assigned to the connectors in Building Systems software and can be found in the catalog. The CEL number corresponds to the connector number, for instance, Connector 1 is known as C1 and has a corresponding CEL1 value.

Flanged and Threaded Connections

Flanged and threaded connections are also known as joint connections, which typically include joint objects such as flanges and couplings. Joint objects in the pipe catalog are primarily found in the *Asymmetric Connectors* and the *Couplings* folders. The name *Asymmetric Connectors* refers to the fact that the object has different connection types on each side. The most obvious example of an asymmetric connector is the flange object.

Another joint object is the coupling, which refers to the fact that the connectors are the same on each side. Figure 6 shows a threaded coupling. Both C1 and C2 are set to be Threaded, and in this case CEL1 and CEL2 are equal.

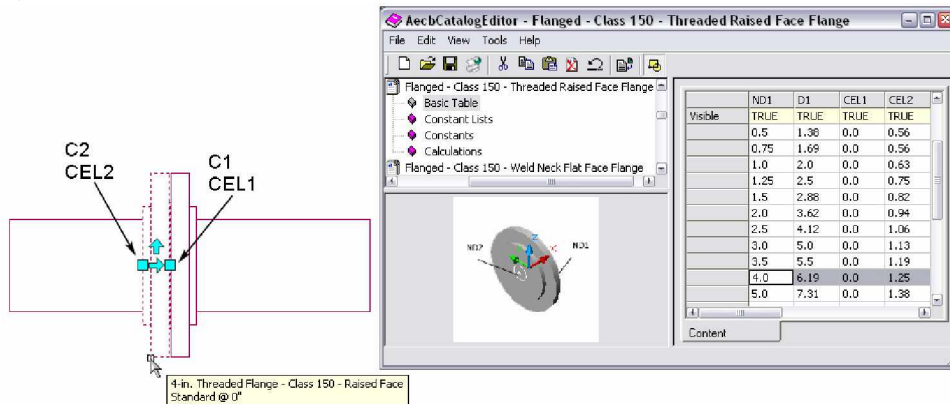

Figure 5: Pipe with flanged connection.

In the case of flange objects, C1 is always located on the face of the flange, and C2 is on the side where the pipe connects. In Figure 5, C1 connection type is Flanged and C2 connection type is Threaded. Since flanged faces mate directly to each other, the CEL1 value is set to 0 inches. The Threaded connection has a CEL2 value of 1.25 inches, which corresponds to the amount of piping that should go into the threaded side of the flange object.

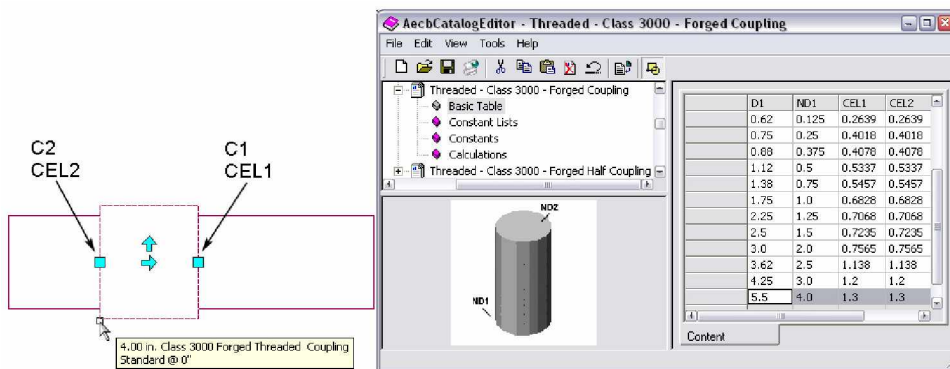

Figure 6: Pipe with threaded coupling connection.

Butt Welded Connections

Butt welded connections have no “joint” object per say. In Building Systems it is simply a matter of the connection type assigned to “Butt Welded.” Figure 7 shows a butt welded pipe connection. Notice that C1 is defined as a Butt Welded connection type, and C2 is undefined.

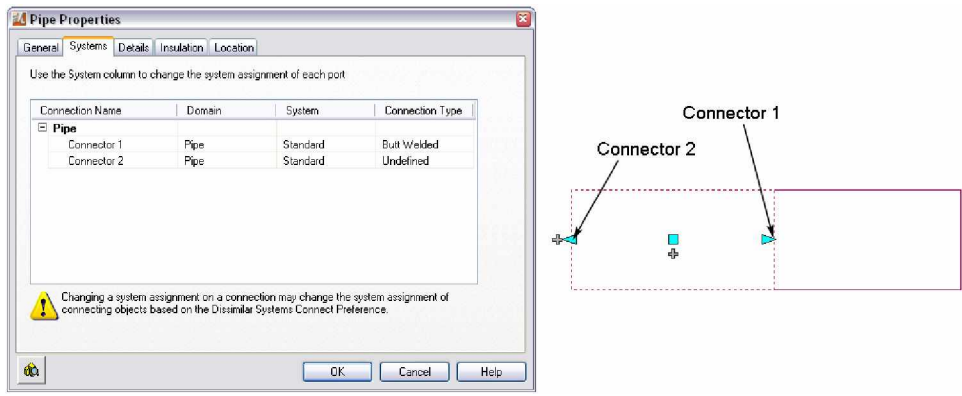

Figure 7: Pipe with butt welded connection.

Grooved Connections

Grooved connections, specifically grooved couplings, have a special characteristic in which the CEL values are used to place the connectors inside the coupling object. This unique object behavior is further described in “Pipe Lengths,” later in this paper.

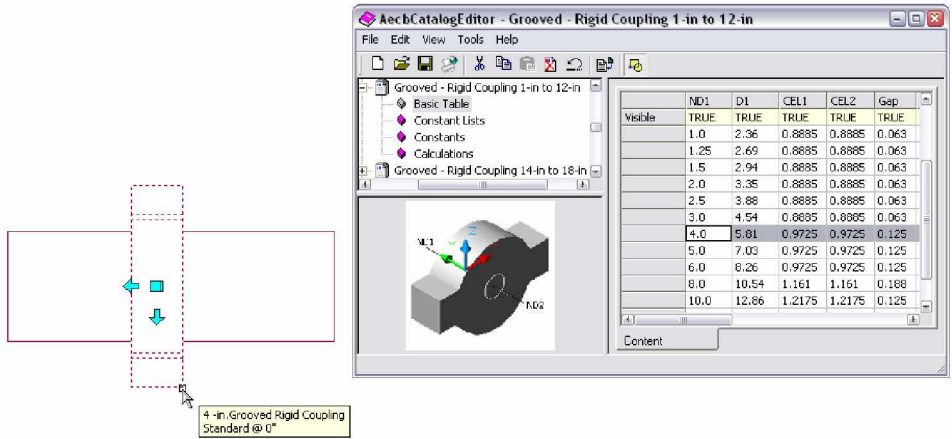

Figure 8: Pipe with grooved coupling connection.

Other Fitting Connections

Fitting objects (elbows, tees, and so forth) also follow the same logic in terms of the connectors. Figure 9 shows an example of a Brazed DWV Elbow, in which both C1 and C2 are set to Brazed, and CEL1 and CEL2 are equal.

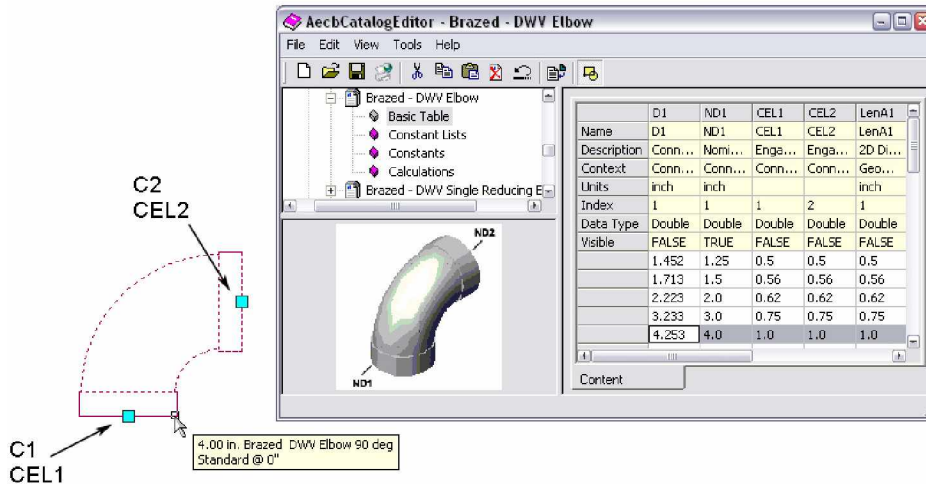

Figure 9: Pipe elbow fitting.

Creating a Piping Layout

The fastest and easiest way to add pipe to a Building Systems model is by using the PIPEADD command. This command provides an efficient way of drawing pipe with the correct piping components automatically inserted. To support this automated behavior, Building Systems provides unique layout functionality based on the type of fittings inserted and the connection type used. To better understand these unique behaviors, first consider the most common layout scenarios: pipe to fitting, pipe to pipe, and fitting to fitting. Then consider the different types of pipe connections: grooved, butt welded, socket welded, brazed, glued, soldered, threaded, crimped, capillary, fusion, and flanged.

Grooved connections have a rather consistent behavior in that a joint object is always required in order to join a pipe to a fitting or to another piece of pipe. See Figure 10.

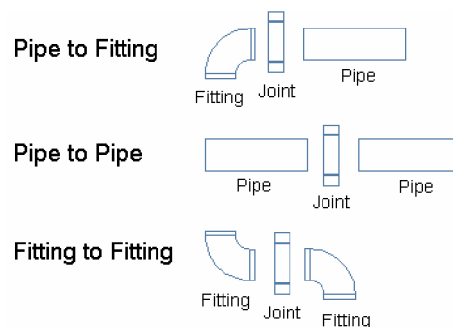

Figure 10: Grooved connections.

Butt welded connections do not require the insertion of a separate joint object because this connection method welds the body of the fitting or pipe together. See Figure 11.

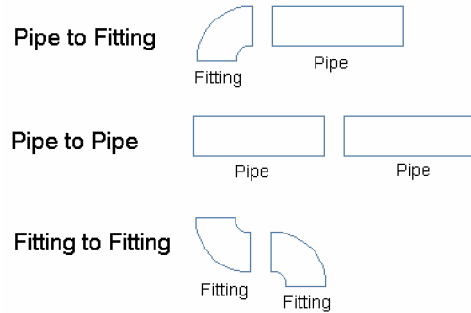

Figure 11: Butt welded connections.

Socket welded, brazed, glued, soldered, threaded, crimped, capillary, and fusion connections all have the same behavior with respect to how the joint objects are to be inserted. The fittings are all female, so no separate joint object is necessary to connect to a fitting. However, when connecting a pipe to pipe, one coupling object is used to hold the pipes together. See Figure 12.

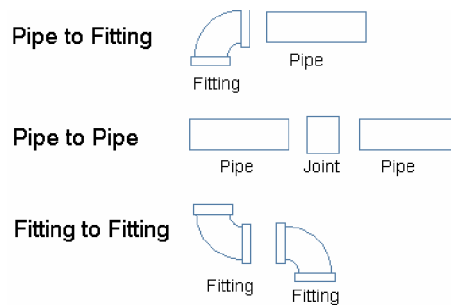

Figure 12: socket welded, brazed, glued, soldered, threaded, crimped, capillary, and fusion connections.

Flanged connections can be tricky simply because the fittings are made with the flanges on them. Only one flange object is required when connecting pipe to fitting. However, two flange objects are required when connecting pipe to pipe. See Figure 13.

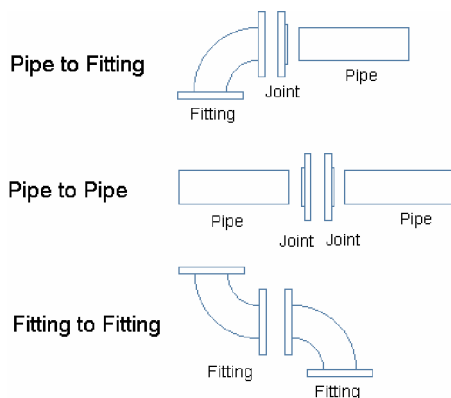

Figure 13: Flanged connections.

Routing Preferences

The PIPEADD command provides an efficient way to draw pipe with the correct piping components inserted automatically. Routing Preferences are the key to this automated behavior, referred to as *Autolayout* in Building Systems. Routing Preferences define which parts to use, depending on the size of the pipe being laid out (see Figure 14).

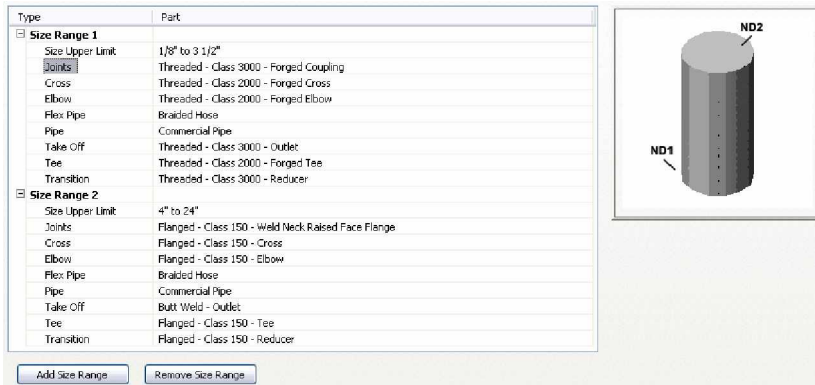

Figure 14: Routing Preferences in Style Manager.

Even though Autolayout behavior is based on the fittings and connection type being inserted, Routing Preferences provides flexibility to define parts based on a range of sizes. For example, in Figure 14 threaded joints are defined for pipe sizes 1/8 inch to 3 1/2 inches (refer to Size Upper Limit value); however, flanged joints are defined for pipe sizes 4 inches to 24 inches. Filtering of parts within Routing Preferences makes selecting which part to define easier. For each part, the associated part list is filtered according to the specified size upper limit, or size range. Therefore, only parts that span the size range are included in the part list.

Choosing a Part

Routing Preferences provide a flexible method for determining how pipes should be laid out based on user-defined standards. However, even after the user has defined Routing Preferences, Building Systems may still require additional information to determine which part to insert based on the unique routing behavior used during Autolayout. In cases such as these, the Choose a Part dialog box appears.

The most common layout behavior that results in prompting with the Choose a Part dialog box is connecting pipe to a flanged part when Routing Preferences is defined as Butt Welded (see Figure 15). In this case, the Choose a Part dialog box returns a list of parts from the Pipe and Fittings catalog that have Flange connectors and fit the size requirements.

Note: If Routing Preferences are defined as Flanged, the Choose a Part dialog box does not appear.

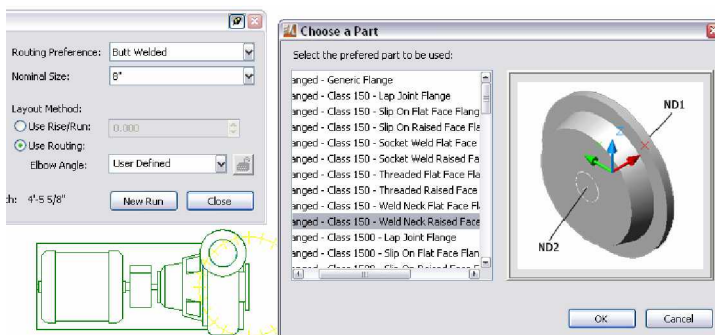

Figure 15: Choosing a flanged part during Autolayout.

The Choose a Part dialog box also appears when the user inserts an MvPart (that is, inline valve) into a piece of pipe that requires a joint object for the connection, specifically Flanged and Grooved connections (see Figure 16).

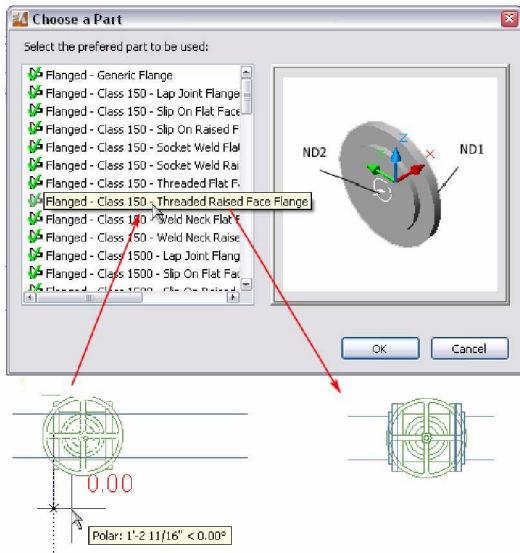

Figure 16: Choosing a part when a joint connection is required.

Pipe Lengths

For pipe layout, knowing how much material is required can be helpful from a constructability standpoint. A key benefit of creating an accurate piping layout in Building Systems is the ability to quickly determine the length of pipe needed. Determining required pipe length requires two components: the actual length of the pipe object itself (length), and the length of pipe depending on the type of fitting or joint object the pipe is connected to (cut length).

In Building Systems, users calculate cut length by adding the CEL values assigned in the catalog to the length of the pipe object. For example, in Figure 17 the cut length of the pipe that is connected between the two threaded elbows is calculated as 4'-10 11/32" + 1.3" + 1.3" = 5'-0 15/16".

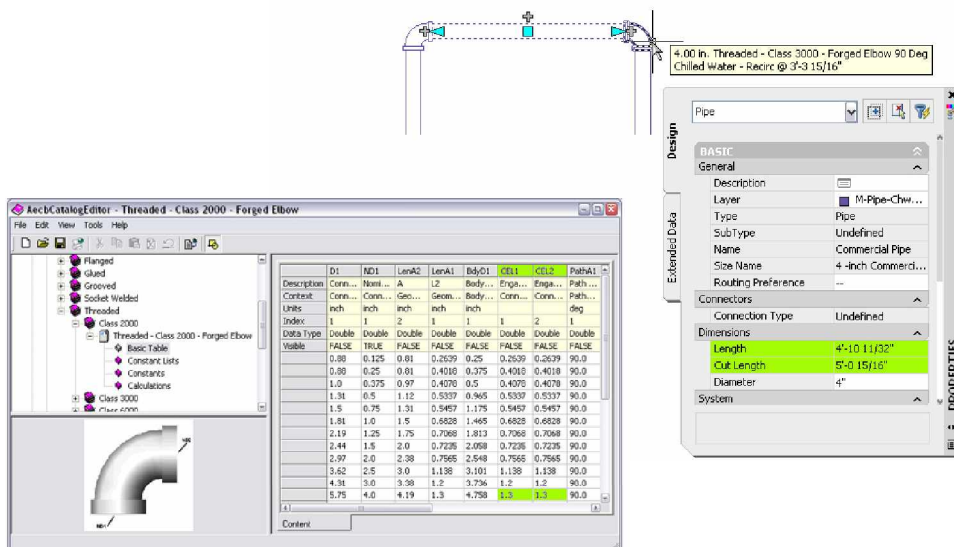

Figure 17: Determining cut length.

This method for calculating cut lengths is used for all connection types with the exception of grooved connections. Grooved connections present a unique scenario since a coupling is required for pipe-to-fitting connections. When inserting a coupling between pipe and fitting during layout in Building Systems, the CEL value defined in the catalog for the grooved coupling object is used to place the connector inside the coupling itself. This step helps to ensure that the coupling is properly placed on the fitting and the pipe is properly placed inside the coupling. Such behavior results in the pipe length being equal to the cut length since the pipe object and fitting extend inside the coupling object (see Figure 18).

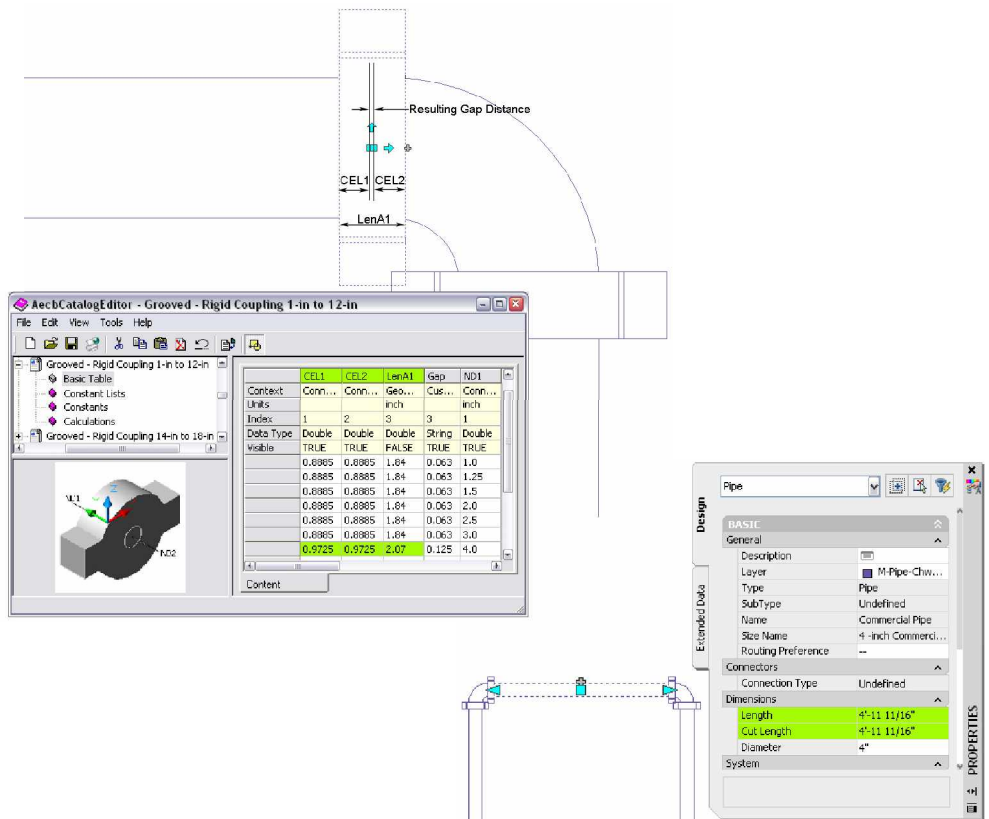

Figure 18: Determining cut length for grooved connections.

PIPELENGTH Command

Building Systems includes a PIPELENGTH command that provides the ability to lay out piping systems based on specified pipe lengths. As mentioned earlier, knowing how much material is required can be helpful from a constructability standpoint. By being able to specify a standard length of pipe that is referenced during layout, users can design piping systems that minimize the need to cut pipe in the field during construction—a potential cost savings that could be significant on projects that require extensive piping.

The PIPELENGTH command can be used to effectively lay out pipe in two ways: have the pipe “broken” into segments during layout or after the pipe layout is complete. Neither method has benefits over the other. Let’s take a closer look at both methods.

Assume that pipe will arrive on site in 20-foot segments. A design for a long pipe run connected to a single pump needs to be laid out in Building Systems. Figure 19 shows the steps required to take advantage of the PIPELENGTH command during layout.

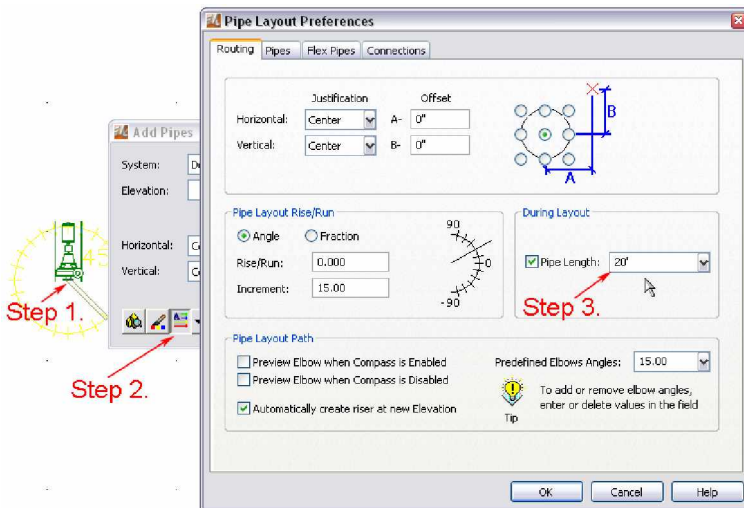

Figure 19: Using Pipe Length command during layout.

Notice that in Figure 20, the resulting pipe layout as selected has a cut length equal to 20 feet even though the length of pipe equals *VARIES*. The cut length value is accurate for scheduling and aids in quantifying the total amount of pipe required, specifically how many lengths of pipe are required.

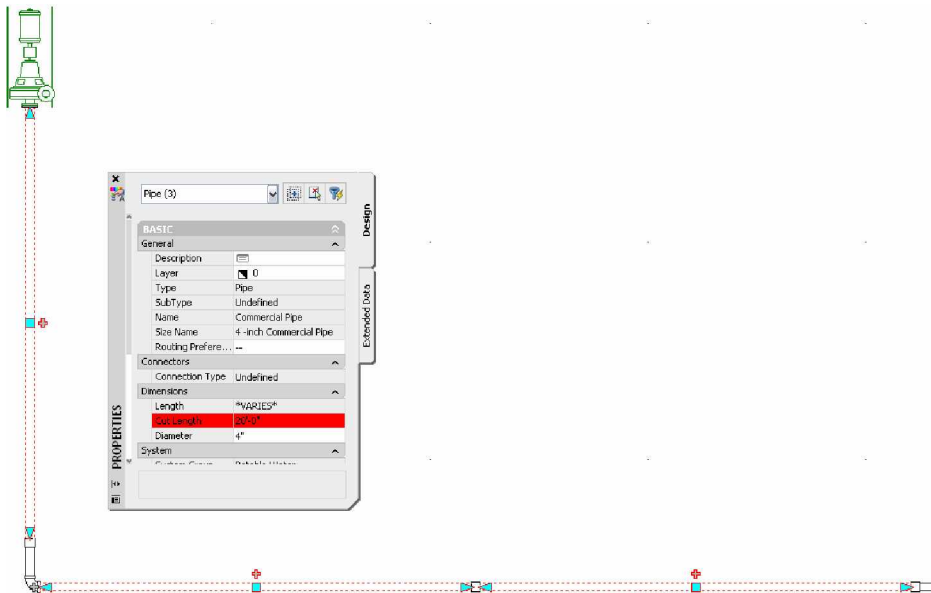
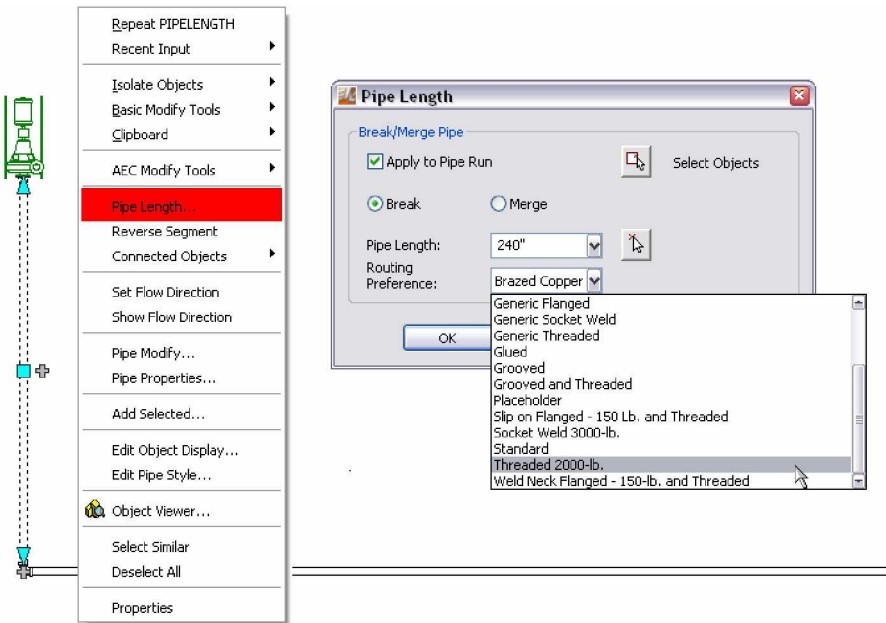

Figure 20: Using PIPELENGTH command during layout.

This same result, individual pipe segments based on a standard pipe length, can be achieved after the pipe layout is complete. Simply select the pipe to “break” and choose Pipe Length from the context-sensitive menu. The Pipe Length dialog box requires additional information to accurately “break” the pipe (see Figure 21).

- Determine how to cut the pipe—whether to apply the “breaks” to the entire pipe run or just to selected pipe objects.
- Consider which Routing Preference to use—what type of connections to use to join pipe segments together.



Note: The PIPELENGTH command can also be used to merge the pipe together to get rid of any joints that are holding two pipes together. This command can be useful if you need to chop up the pipe to different cut lengths.

Figure 21: Using PIPELENGTH command after layout.

Summary

In summary, Autodesk Building Systems provides enhanced tools for accelerated production of piping design layouts. Find pipe and fittings quickly in an easy-to-navigate pipe catalog. Take advantage of Autolayout behavior to efficiently lay out pipe. Define Routing Preferences to meet design standards. And benefit from additional tools such as Pipe Length to help minimize the amount of materials needed during construction. For more information about Autodesk Building Systems, go to www.autodesk.com/buildingsystems.

Autodesk, AutoCAD, Buzzsaw, DWF, DWG, DXF, Revit, and 3ds Max are registered trademarks or trademarks of Autodesk, Inc., in the USA and other countries. All other brand names, product names, or trademarks belong to their respective holders. Autodesk reserves the right to alter product offerings and specifications at any time without notice, and is not responsible for typographical or graphical errors that may appear in this document. Computer aided design software and other technical software products are tools intended to be used by trained professionals and are not substitutes for your professional judgment.

© 2006 Autodesk, Inc. All rights reserved.